



Distributor of mechanical IC samples (dummy components),
test boards, kits and SMD production tools and equipment.

Frequently Asked Questions

What are dummy components?*

Dummy components are the exact mechanical equivalent of functional electronic components.

Why use dummy components?

Dummies save money. In cases where only mechanical characteristics are required, dummy components can be used instead of live functioning components. Since there is no expensive die inside the package, the cost for performing mechanical testing is significantly lower.

Who is Practical Components?

Practical Components is a team of dedicated electronic industry professionals offering value pricing, on-time delivery, and superior service to our customers. The Practical Components team is ready to provide project assistance in the areas of technical component knowledge, drawings, component land patterns, and PCB practice kits.

What is a PCB Practice Kit?

A PCB Practice Kit contains both the PC practice board and the necessary dummy components so customers can conduct assembly process evaluation without using high-cost, live components and functional PC boards. Kits are available in a single pack for employee hand soldering training or packaged for production equipment evaluation. Both X, Y Theta data and Gerber data are available without charge.

What other products are offered by Practical Components?

In addition to dummy components, Practical carries solder training aids, tools and related equipment, IPC products and designs custom printed circuit boards. Your sales representative can supply technical information and pricing on all our products.

Who uses dummy components?

Companies that are involved with electronic component assembly, testing, evaluation and employee training.

Contact Practical Components

If you have any additional questions concerning Practical Components, our products or policies, please contact us.

Practical Components, Inc.
10762 Noel Street
Los Alamitos, CA 90720 USA
Tel: 1-714-252-0010
Fax: 1-714-252-0026
E-mail: klaphen@practicalcomponents.com
Web Site: www.PracticalComponents.com
www.TrustPCI.com

Main E-mail	Info@TrustPCI.com
Sales Manager	Russell Kido / rkido@TrustPCI.com
Sales Engineer/Distributors.....	Kym Bell / kbell@TrustPCI.com
Sales Engineer	Lisa Laphen / llaphen@TrustPCI.com
Technical Support.....	techsupport@TrustPCI.com
Purchasing Agent	Deanne Guzman / dguzman@TrustPCI.com
General Manager	Kevin Laphen / klaphen@TrustPCI.com

* Disclaimer: Dummy components are only to be used for evaluation and testing purposes. Practical Components is not responsible for product that is used as a "live" package using live die assembly. Dummy samples are not to be used for 1st reliability testing.

Practical Components is the exclusive distributor of
Amkor Technology Mechanical Components.

How To Place Your Order

Our sales staff is ready to serve you from 8:00 A.M. to 4:30 P.M. Pacific Standard Time, Monday through Friday. Our fax lines are open 24 hours every day.

Fax and E-mail orders received after normal business hours are processed the next business day. Please include your telephone and fax numbers so we can confirm your order.

Our website www.TrustPCI.com is always available and is loaded with valuable information about our products including detailed component drawings, daisy-chain patterns, white papers, photos and data sheets. The site has many products such as hand solder training kits available for purchase online.

Bill / Remit to:

Practical Components, Inc.
PO Box 1037
Los Alamitos, CA 90720-1037 USA

Ship to:

Practical Components, Inc.
10762 Noel Street
Los Alamitos, CA 90720 USA

Tel: 1-714-252-0010
Fax: 1-714-252-0026
E-mail: klaphen@practicalcomponents.com
Web Site: www.TrustPCI.com

F.O.B. is Los Alamitos, CA USA

Terms and Conditions

Out Of Stock Items: Items not available for immediate shipment will be shipped as they become available. Items not available at the end of 90 days will be cancelled. The number of back-ordered days may be extended beyond 90 days with customer approval.

Return Policy: Returns must be made promptly and accompanied by a return authorization number. Please contact a customer service representative to obtain a return authorization number. All returns must be made within 30 days of date of invoice and accompanied by return authorization number.

- Return freight charges must be prepaid.
- C.O.D. returns cannot be accepted.
- Return merchandise in original packaging and in resalable condition.
- Please note that items returned due to customer error may be subject to a restocking charge of 25%.
- Non-catalog items are not returnable.

Catalog Listings: Not all products listed in this catalog are maintained in stock, and all product specifications for each product are current as of the date of publication. Product listings, specifications and prices for each product are subject to change without notice.

Product Liability: Practical Components' sole obligation for products that prove to be defective within 10 days of purchase will be replaced or

refunded. Practical Components gives no warranty either expressed or implied and specifically disclaims all other warranties, including warranties for merchantability and fitness.

In no event shall Practical Components' liability exceed the buyer's purchase price nor shall Practical Components be liable for any indirect or consequential damages.

Shipment Damage: Merchandise is carefully packaged in compliance with carrier requirements. Claims for loss or damage in transit must be made with the carrier by the customer. All shipments should be unpacked and inspected immediately upon receipt. If damage does not become apparent until shipment is unpacked, make a request for inspection by the carrier's agent. Failure to do so will result in the carrier refusing to honor the claim.

Non-Catalog Items: Merchandise not listed in our catalog, if available from our suppliers, may be subject to minimum order quantities and/or special handling charges. Shipment is made as quickly as deliveries are received from our suppliers. Special order products are sold on a non-returnable basis.

Quotations: All items are subject to prior sale. A quote is valid for 30 days.

Dishonored Check Policy: If a check you give us as payment is dishonored for any reason by the bank or any other institution on which it is drawn, you agree to pay us \$20.00 as a service charge. In addition, you agree to pay any other reasonable charges imposed by any check verification company or collection agency that we may use for collection.

Prices/Quantities: Prices are subject to change without notice and quantities may be limited.

Handling Charge: A \$5.00 handling charge applies to all orders.

Terms: We accept Visa, MasterCard and American Express (minimum order is \$50.00).



Open Account: We bill on a net 30-day basis to customers with approved credit.

Large Quantity Quotations: Practical Components will be happy to quote quantities in excess of the amounts shown in the catalog.

Freight Charges: On open accounts, actual freight charges are added to the invoice. A packing and handling fee of \$5.00 is added to the order. C.O.D. accounts will have the freight charges pre-billed to the C.O.D. total in addition to a \$5.00 packing and handling charge.

Tray Charge: A \$12.00 tray charge is added if customer orders less than a full tray quantity.

Special Requirements: Please include specific instructions if you require special packing, marking, shipping, routing or insurance.

*All prices are in USD (\$).

Table of Contents

Components

CSPnl (RDL) Wafer	4
eWLP Embedded Wafer Level Package	5
WLP	6
WLP	7
CVBGA	8
PCB368- .3 mm Pitch CVBGA	9
CTBGA	10
CABGA	11
PBGA	12
LGA	13
OmQFN	14
MLF MicroLeadFrame	15
LQFP	16
TQFP	17
QFP	18
Daisy-Chain Patterns	19
PLCC	20
SOIC	21
PDIP	22
Through-Hole Glass Diodes	22
SSOP	23
TSSOP	24
TSOP	25
SMC	26
SMR	27
MELF Resistors	28
SMTA	29
SMT	30
SMT	31
SME	32
MELF Diodes	32
Through-Hole Transistors	33
Axial Leaded Resistors	33
CQFP	34
LCC	34
CTReels	36
Tape and Reel Specifications	37
Advanced Wafer Packages	
Advanced Wafer Packages-TEG Wafers and Test Elements	38
Advanced Wafer Package Line Up (1)	39
Advanced Wafer Package Line Up (2)	40
MB50-0101JY	41
MB80-STG0101JY and AS8R	42
MB130A-STG0101JY and MB130B-STG0101JY	43
MB6020-0102JY	44
CC40-0101JY	45
IP40-0101JY	46
IP40A-0101JY	46
Concept of CC80 Series	47
CC80-0101JY	48
IP80-0101JY Silicon Interposer [for CC80-0101JY]	49
KIT CC80(T)-0106JY [MAP]	50
KIT CC80CL-0100JY [MAP]	51
CC80TSV-0101JY	52
CONCEPT of CC80MarkIV SERIES	53
CC80MarkIV-0101JY (A/B)	54
IP80 MarkIV-0101JY Silicon Interposer [for CC80MarkIV-0101JY(A/B)]	55
WM40-0101JY	56
WM40-0102JY	57
WM40-0103JY	58
IPWM40-0101JY [for WM40-0103JY]	59
CONCEPT of HBM SERIES	60
HBM_T-0100JY	61
IPHBM-0100JY Silicon Interposer [for HBM_T-00JY]	62
FC150LC-0102JY	63
KIT FC150LC(S)-0303JY	64
FC120JY	65
KIT FC120 [for FC120JY]	66
FC150JY and FC150SCJY	67

KIT FC150 for FC150JY	68
FC150JY and FC200JY Glass	69
FC200JY and FC200SCJY	70
KIT FC200 for FC200JY	71
FBW Series	72
Full Bump Wafer FBW50	73
WLP TEG (0.5mm pitch, 0.4mm pitch & 0.3mm pitch)	74
KIT WLP(S)300P/400P -2	75
WLP (Free Size Cut TEG : TEG0306, TEG03507, TEG0408, TEG0510)	76
STAC-0101JY	77
KIT STAC(S)-0202JY	78
STACTEG-150FA-0101JY	79
STACTEG-300FA-0101JY	79
HPW-0101JY	80
HPWTEG-150FA-0101JY	81
HPWTEG-300FA-0101JY	81
HPW MarkII-0101JY	82
LCD30A-0101JY	83
KIT LCD30-0101JY	84
KIT COF30-0101JY	84
PWB8-0101JY	85
ME (1015, 2025, 3035) (for Migration Test)	86
SIPOS-SI0631	87
ITO1101-0100JY (for MicroLineEvaluation)	88
ITO1102-0100JY (for Micro Line Evaluation)	89
Kit Identifier	90
Kit Identifier	91

Printed Circuit Boards & Kits

Conformal Coating Process Flow Chart	92
Test Boards for Cleanliness and Conformal Coating	93
Test Boards for Cleanliness and Conformal Coating	94
Test Boards for Cleanliness and Conformal Coating	95
SIR Test Board and Kit	96
SMTA Saber Evaluation Board and Kit	97
B-52 CRET Rev B	98
B-52 CRET Rev B	99
SMTA-UltraHDI Miniaturized Test Board	100
SMTA-UltraHDI Miniaturized	101
Foresite Umpire Test Board	102
SMTA Solder Paste Board and Kit	103
Custom PC Practice Boards and Kits	104
Single Pack Hand Solder Kit	105
Terminal and Wire Kit	106
PC003 Solder Practice Board and Kit	107
MLF Test Board and Kits	108
MLF Test Board and Kits	109
Solder Practice Board and Kits	110
Solder Practice Board and Kits	111
Mixed Technology Board and Kit	112
BGA Fine Pitch Board and Kit	113
BGA Global Daisy-Chain Test Kit	114
BGA Global Daisy-Chain Test Kit	115
Through-Hole Solder Training Kits	116
IPC 9850 Attribute Defect Rate Kit	117
Rework Kits	118
IPC Compliant Hand Soldering Kit	119
IPC/WHMA-A-620D Space Addendum Kit	120
IPC/WHMA-A620 Wire Harness Kit	121
Lead-Free Zero-Ohm SMD Resistor Kit	122
AIM Solder Print Test Board and Kit	123
SMT/PTH	124
Jabil Solder Paste Evaluation	125

Practical Production Tools

CircuitMedic	126
--------------------	-----

CSPnl (RDL) Wafer



Practical Components introduces the CSPnl (RDL) dummy wafers from Amkor. The CSPnl Bump on Redistribution (RDL) option adds a plated copper redistribution layer to route I/O pads to JEDEC/EIAJ standard pitches, avoiding the need to redesign legacy parts for CSP applications. Nickel-based or copper UBM is offered, along with polyimide or PBO repassivation. CSPnl with RDL utilizes industry-standard surface mount assembly and reflow techniques, and does not require underfill.

This 8 inch wafer can be provided diced into individual die or as an uncut wafer. The wafer can be provided with SAC405 bumps.

Pad pitch is 400um (0.4mm). Wafer thickness is 725um, with back grinding available to 200um.

Pads on this wafer are daisy chained and can be cut to any sized request. Packaging is tape and reel bumps down for cut die or cut and in the ring. Uncut 8inch wafers are shipped in plastic wafer packs. There is a lot of flexibility with this type of component.

In addition to the wafer Practical Components can also provide a test board (substrate) on request.

Please call our technical representatives at 714-252-0010 for additional information.

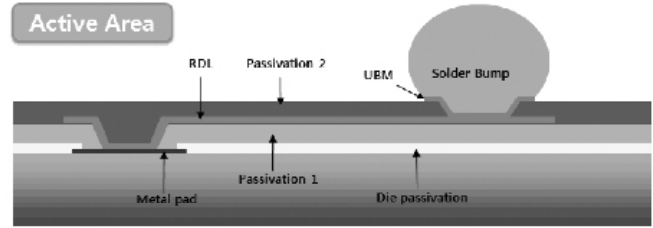

Part Description	I/O Count	Die Size	Pitch	Matrix	Projected Die Yield	Alloy
A-CSPnl4-0.76mm-.4mm-DC	4	0.76	.4mm	2x2	40,000	SAC405, No Solder Ball
A-CSPnl16-1.56mm-.4mm-DC	16	1.56	.4mm	4x4	10,000	SAC405, No Solder Ball
A-CSPnl36-2.36mm-.4mm-DC	36	2.36	.4mm	6x6	4,500	SAC405, No Solder Ball
A-CSPnl64-3.16mm-.4mm-DC	64	3.16	.4mm	8x8	2,500	SAC405, No Solder Ball
A-CSPnl100-3.96mm-.4mm-DC	100	3.96	.4mm	10x10	1,500	SAC405, No Solder Ball
A-CSPnl144-4.76mm-.4mm-DC	144	4.76	.4mm	12x12	1,000	SAC405, No Solder Ball
A-CSPnl196-5.56mm-.4mm-DC	196	5.56	.4mm	14x14	500	SAC405, No Solder Ball

Notes

- Trace material: Copper
- Trace thickness: 3um
- Trace width: 100um
- Bump pad shape: Circular / Square
- Bump pad size: 225/290um
- Tape and Reel: Width = 8mm Pitch = 4mm

Part Description System

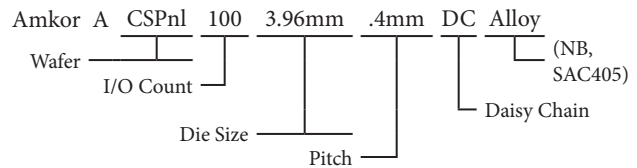

- Add "WR" to end of part number for Wafer Cut and left in Seal Ring.
- Add "TR" to end of part number for die on Tape and Reel.
- Add "NB" to end of part number for No Solder Balls.
- Add "SAC405" to end of part number for Lead-Free.
- Add "W" to end of part number for Uncut Wafer.



Practical Components is the exclusive distributor of Amkor Technology Mechanical Components.



eWLP Embedded Wafer Level Package

Practical Components is offering Amkor's embedded copper posts/pad on a eWLP (embedded Wafer Level Package) 8 inch wafer. eWLP wafers have copper posts that are embedded into the die. Size of the posts is 8um to 10um. Pitch between the copper posts is 400um (0.4mm).

Wafer thickness is 725um and can be back grinded to 200um.

These wafers can be supplied by uncut wafer or cut die, packaged on tape and reel with pads down. Copper pillar dummy test wafers provide an excellent opportunity to investigate the effectiveness of the flip chip die attach process.

Practical Components technical staff can provide additional information on the new Amkor eWLP test wafers. In addition to the wafers and die, Practical can supply test vehicles for the eWLP test die.

Each die is daisy chained and customer can have the wafer cut to match a required die size.

Call for more information. 714-252-0010

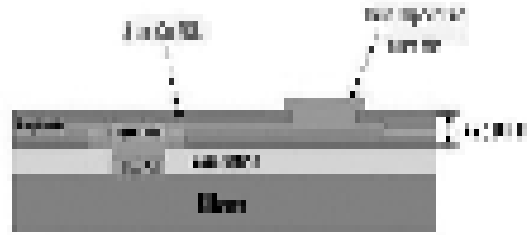

Part Description	I/O Count	Die Size	Pitch	Matrix	Projected Die Yield	Alloy
A-eWLP4-0.76mm-.4mm-DC	4	0.76	.4mm	2x2	40,000	No Solder Ball
A-eWLP16-1.56mm-.4mm-DC	16	1.56	.4mm	4x4	10,000	No Solder Ball
A-eWLP36-2.36mm-.4mm-DC	36	2.36	.4mm	6x6	4,500	No Solder Ball
A-eWLP64-3.16mm-.4mm-DC	64	3.16	.4mm	8x8	2,500	No Solder Ball
A-eWLP100-3.96mm-.4mm-DC	100	3.96	.4mm	10x10	1,500	No Solder Ball
A-eWLP144-4.76mm-.4mm-DC	144	4.76	.4mm	12x12	1,000	No Solder Ball
A-eWLP196-5.56mm-.4mm-DC	196	5.56	.4mm	14x14	500	No Solder Ball

Notes

- Ball Place or Electroplated: Electroplated
- Bump On Pad or redistribution Layer: Redistribution Layer
- Bump Material: Cu bump
- Bump Height: 10 um
- Bump pitch: 400 um
- Bump Shear Strength: >2 g/mil²
- Plating Area 30: 5948 mm²
10: 10804 mm²
- Tape and Reel: Width =8mm Pitch = 4mm

Part Description System

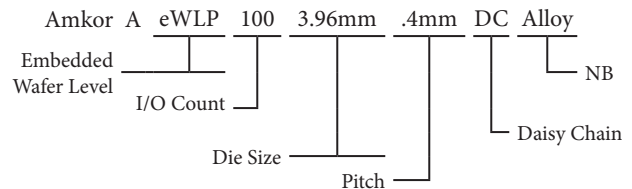

- Add "WR" to end of part number for Wafer Cut and left in Seal Ring.
- Add "TR" to end of part number for die on Tape and Reel.
- Add "NB" to end of part number for No Solder Balls.
- Add "W" to end of part number for Uncut Wafer.

Practical Components is the exclusive distributor of Amkor Technology Mechanical Components.

WLP

Wafer Chip Size Package

WLP uses interconnection technology to effectively utilize the chip area by making it possible to form electrodes over the entire chip surface. This eliminates the need for the wire bonding space required by previous wiring methods. Also, electrodes are formed using copper posts for a simple structure.

All of this means that the area of the finished package is exactly the same compact size as the original chip. It also simplifies mounting and contributes to easier high-density mounting. WLP is the perfect choice for packaging chips used in portable telephones, digital cameras, and other applications where mounting space is severely restricted.

Part Description	"I/O Count"	Pitch	"Body Size"	Matrix	Alloy
.3mm Pitch					
WLP100-.3mm-3mm-DC	100	.3mm	3mm	10x10	96.5%Sn/3.0%Ag/0.5%Cu
WLP144-.3mm-3.6mm-DC	144	.3mm	3.6mm	12x12	96.5%Sn/3.0%Ag/0.5%Cu
WLP196-.3mm-4.2mm-DC	196	.3mm	4.2mm	14x14	96.5%Sn/3.0%Ag/0.5%Cu
WLP256-.3mm-4.8mm-DC	256	.3mm	4.8mm	16x16	96.5%Sn/3.0%Ag/0.5%Cu
WLP264-.3mm-6mm-DC	264	.3mm	6mm	17x17	96.5%Sn/3.0%Ag/0.5%Cu
WLP400-.3mm-6mm-DC	400	.3mm	6mm	20x20	96.5%Sn/3.0%Ag/0.5%Cu
WLP676-.3mm-7.8mm-DC	676	.3mm	7.8mm	26x26	96.5%Sn/3.0%Ag/0.5%Cu
WLP900-.3mm-9mm-DC	900	.3mm	9mm	30x30	96.5%Sn/3.0%Ag/0.5%Cu
WLP1600-.3mm-12mm-DC	1600	.3mm	12mm	40x40	96.5%Sn/3.0%Ag/0.5%Cu
WLP2500-.3mm-15mm-DC	2500	.3mm	15mm	50x50	96.5%Sn/3.0%Ag/0.5%Cu
.35mm Pitch					
WLP100-.35mm-3.5mm	100	.35mm	3.5mm	10x10	96.5%Sn/3.0%Ag/0.5%Cu
WLP144-.35mm-4.2mm	144	.35mm	4.2mm	12x12	96.5%Sn/3.0%Ag/0.5%Cu
WLP196-.35mm-4.9mm	196	.35mm	4.9mm	14x14	96.5%Sn/3.0%Ag/0.5%Cu
WLP256-.35mm-5.6mm	256	.35mm	5.6mm	16x16	96.5%Sn/3.0%Ag/0.5%Cu
WLP400-.35mm-7.0mm	400	.35mm	7.0mm	20x20	96.5%Sn/3.0%Ag/0.5%Cu
WLP676-.35mm-9.1mm	676	.35mm	9.1mm	26x26	96.5%Sn/3.0%Ag/0.5%Cu
WLP900-.35mm-10.5mm	900	.35mm	10.5mm	30x30	96.5%Sn/3.0%Ag/0.5%Cu
WLP1600-.35mm-14.0mm	1600	.35mm	14.0mm	40x40	96.5%Sn/3.0%Ag/0.5%Cu
WLP2500-.35mm-17.5mm	2500	.35mm	17.5mm	50x50	96.5%Sn/3.0%Ag/0.5%Cu
.4mm Pitch					
WLP100-.4mm-4mm-DC	100	.4mm	4mm	10x10	96.5%Sn/3.0%Ag/0.5%Cu
WLP144-.4mm-6mm-DC	144	.4mm	6mm	13x13	96.5%Sn/3.0%Ag/0.5%Cu
WLP196-.4mm-5.6mm-DC	196	.4mm	5.6mm	14x14	96.5%Sn/3.0%Ag/0.5%Cu
WLP256-.4mm-6.4mm-DC	256	.4mm	6.4mm	16x16	96.5%Sn/3.0%Ag/0.5%Cu
WLP400-.4mm-8mm-DC	400	.4mm	8mm	20x20	96.5%Sn/3.0%Ag/0.5%Cu
WLP676-.4mm-10.4mm-DC	676	.4mm	10.4mm	26x26	96.5%Sn/3.0%Ag/0.5%Cu
WLP900-.4mm-12mm-DC	900	.4mm	12mm	30x30	96.5%Sn/3.0%Ag/0.5%Cu
WLP1600-.4mm-16mm-DC	1600	.4mm	16mm	40x40	96.5%Sn/3.0%Ag/0.5%Cu
WLP2500-.4mm-20mm-DC	2500	.4mm	20mm	50x50	96.5%Sn/3.0%Ag/0.5%Cu
.5mm Pitch					
WLP100-.5mm-5mm-DC	100	.5mm	5mm	10x10	96.5%Sn/3.0%Ag/0.5%Cu
WLP144-.5mm-6mm-DC	144	.5mm	6mm	12x12	96.5%Sn/3.0%Ag/0.5%Cu
WLP196-.5mm-7mm-DC	196	.5mm	7mm	14x14	96.5%Sn/3.0%Ag/0.5%Cu
WLP256-.5mm-8mm-DC	256	.5mm	8mm	16x16	96.5%Sn/3.0%Ag/0.5%Cu
WLP400-.5mm-10mm-DC	400	.5mm	10mm	20x20	96.5%Sn/3.0%Ag/0.5%Cu
WLP676-.5mm-13mm-DC	676	.5mm	13mm	26x26	96.5%Sn/3.0%Ag/0.5%Cu
WLP900-.5mm-15mm-DC	900	.5mm	15mm	30x30	96.5%Sn/3.0%Ag/0.5%Cu
WLP1600-.5mm-20mm-DC	1600	.5mm	20mm	40x40	96.5%Sn/3.0%Ag/0.5%Cu
WLP2500-.5mm-25mm-DC	2500	.5mm	25mm	50x50	96.5%Sn/3.0%Ag/0.5%Cu

Notes

- Ultra thin type, Ultra miniature, Lightweight
- High current capacity and good heat radiation
- High reliability of WLP as semiconductor package makes KGD issues cleared.
- Coplanarity (5 to 10 μ m)
- Available diced and left in ring or in trays.

Part Description System

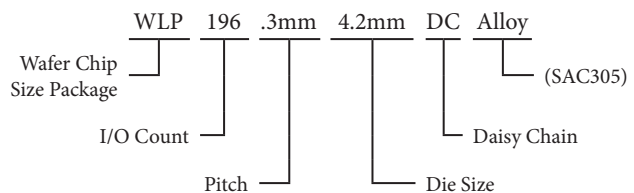

- Add "TR" to end of part number for die on Tape and Reel.
- Add "SAC305" to end of part number for Lead-Free.

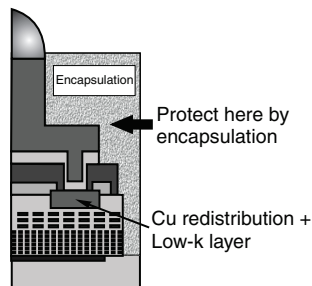
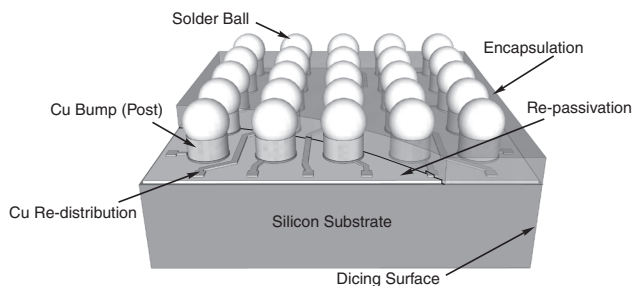

WLP196-.3mm-4.2mm (14x14 Matrix)

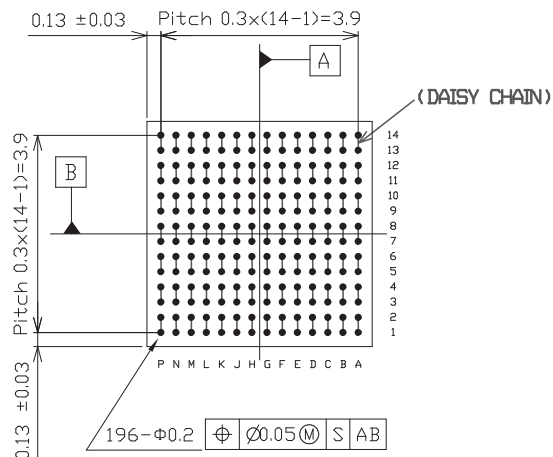

WLP256-.3mm-4.8mm (16x16 Matrix)

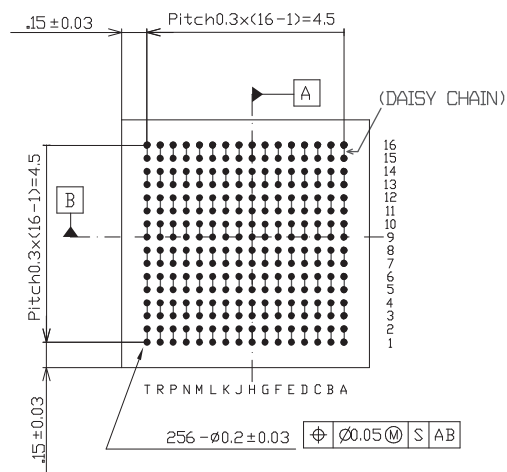

WLP264-.3mm-6mm (17x17 Matrix)

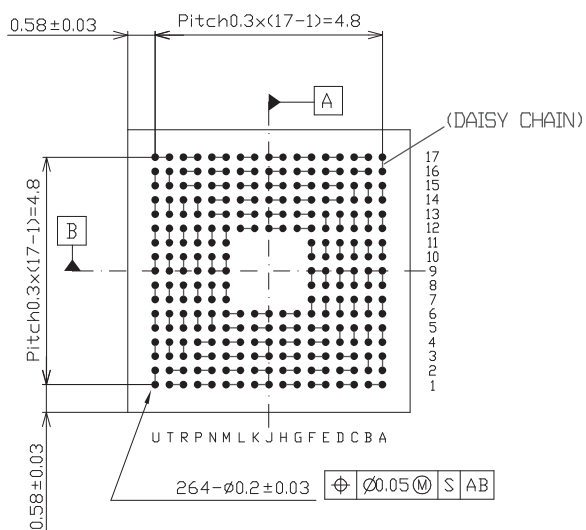

WLP400-.3mm-6mm (20x20 Matrix)

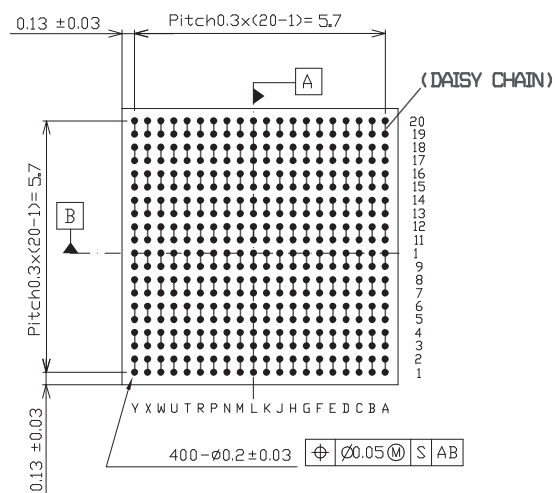

CVBGA

Very Thin ChipArray® BGA



ChipArray® (CVBGA) package offering by Amkor have a .3mm and .4mm pitch. In addition to the standard core ChipArray® package (CABGA and CTBGA), Amkor offers thinner mold cap thickness of 1.0mm max. By utilizing a thin core laminate, much denser routing can be achieved, thereby enabling more I/O's in a given footprint.

Due to their small size and I/O density Amkor's ChipArray® product family is an excellent choice for new devices requiring a small footprint and low mounted height.

The .3mm and .4mm CVBGA packages have become popular choices for electronic assembly. They are identical to the live package without the expensive IC die inside. The dummy versions are made of the same materials on the same manufacturing lines and have the same size, thermal and soldering properties as the live equivalent without the cost of a live die.



CVBGA Very Thin ChipArray® BGA

Part Description	I/O Count	Pitch	Body Size	Ball Matrix	Ball Alignment	Quantity per Tray	Available Lead Free Alloy
.3mm Pitch							
A-CVBGA368-.3mm-8mm	368	.3mm	8mm	23x23	Perimeter	260	SAC105 only
.4mm Pitch							
A-CVBGA97-.4mm-5mm	97	.4mm	5mm	10x10	Full Array	360	SAC105, SAC305
A-CVBGA360-.4mm-10mm	360	.4mm	10mm	23x23	Perimeter	168/250	SAC105, SAC305
A-CVBGA432-.4mm-13mm	432	.4mm	13mm	31x31	Perimeter	160	SAC105, SAC305

Notes

- Parts are packaged in JEDEC trays.
- All components are daisy-chained.
- Moisture sensitivity is JEDEC level 3.
- Daisy-chained connections are connections between I/O (input/output) of the component
- Lead free parts are available with 96.5%Sn/3.0%Ag/0.5%Cu alloy (SAC305) and 98.5%Sn/1.0%Ag/0.5%Cu alloy (SAC105).
- Eutectic 63/37 SnPb Solder ball material may be available. Please call.

Part Description System

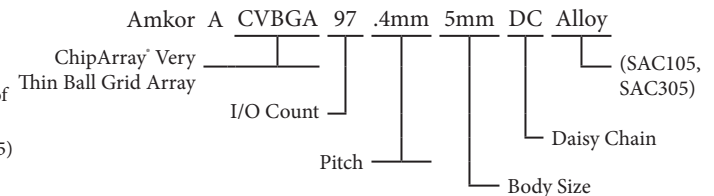

- Add "TR" to end of part number for Parts on Tape and Reel.
- Add "SAC105" or "SAC305" to end of .4mm pitch part number for Lead-free.

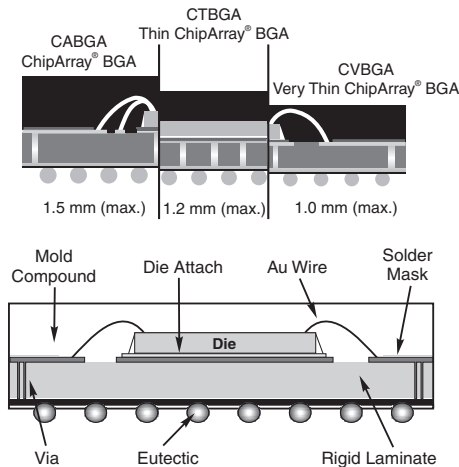

.3mm Package



Practical Components is the exclusive distributor of Amkor Technology Mechanical Components.



For recommended kits see pages, 103, 110, 113, 123.

PCB368- .3 mm Pitch CVBGA

Evaluation and Qualification Test Board

The PCB368-8 Evaluation Board is a test vehicle for the .3mm pitch CVBGA component.

Solder practice test vehicle PCB boards and kits are used for machine setup, evaluation, qualification, workflow analysis, prototyping, testing, and solder profiling.

For this component we have added a PCB368-8 mm Evaluation Board that is ideal for testing, evaluating and qualifying this fine-pitch technology. With Practical Components test boards and the necessary dummy components, customers can conduct assembly process evaluation without using high-cost, live components and functional PC boards. Kits are available packaged for production equipment evaluation.

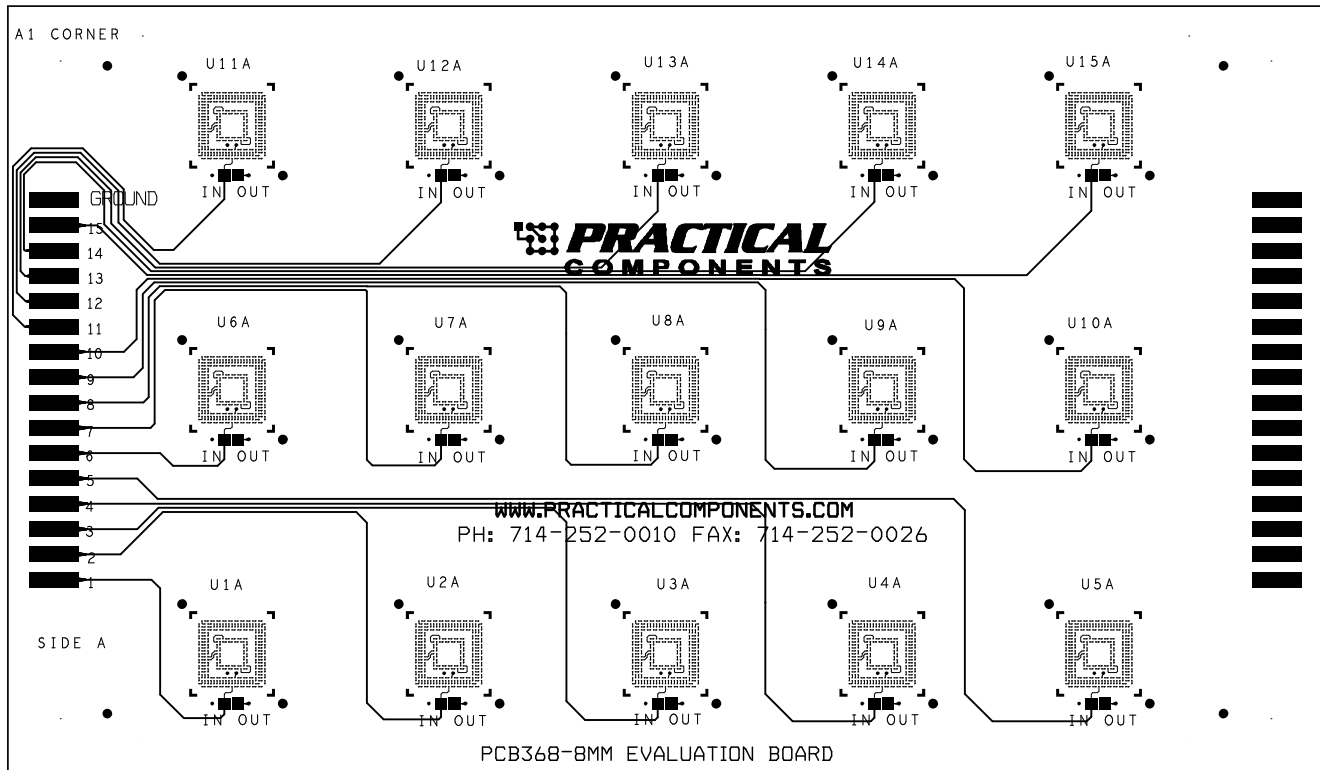

Notes

- Both X, Y Theta data and Gerber data are available without charge.
- Board Size: 77 x 132mm
- 1mm thick
- 4 layers
- 15 pads for the CVBGA368 package
- Offered with OSP, ImAg & ENIG finishes

CTBGA

ChipArray® Thin Core Ball Grid Array



Part Description	I/O Count	Pitch	Body Size	Ball Matrix	Ball Alignment	Quantity per Tray	Available Lead Free Alloy
<i>.5mm Pitch</i>							
A-CTBGA84-.5mm-6mm	84	.5mm	6mm	10x10	Perimeter	608	SAC105,SAC305
A-CTBGA84-.5mm-7mm	84	.5mm	7mm	12x12	Perimeter	476	SAC105, SAC305
A-CTBGA108-.5mm-7mm	108	.5mm	7mm	12x12	Perimeter	476	SAC105, SAC305
A-CTBGA132-.5mm-8mm	132	.5mm	8mm	14x14	Perimeter	360	SAC105, SAC305
A-CTBGA228-.5mm-12mm	228	.5mm	12mm	22x22	Perimeter	189	SAC105, SAC305

Notes

- Parts are packaged in JEDEC trays
- All components are daisy-chained.
- <0.12mm (5 mil) coplanarity.
- BT (Bismaleimide-Triazine) substrates or equivalent.
- Package thickness is 1.1mm max for 0.5mm pitch packages.
- Moisture sensitivity is JEDEC level 3.
- Lead-free parts are available with (SAC305) 96.5%Sn/3.0%Ag/0.5%Cu alloy or (SAC105)98.5%Sn/1.0%Ag/0.5%Cu is also available.
- CABGA, CVBGA and CTBGA parts are available without solder balls, which makes the package LGA.

Part Description System

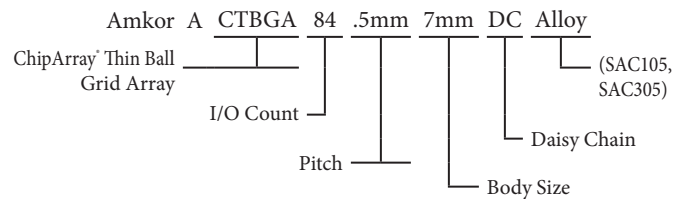

- Add "TR" to end of part description for Tape and Reel
- Add "SAC105" or "SAC305" to end of part description for Lead-Free.



For recommended kits see pages, 100, 103, 113, 123.

Practical Components is the exclusive distributor of Amkor Technology Mechanical Components.

ChipArray® (CABGA) packages are offered in laminate format and are available as Ball Grid Array. The near chip size standard outlines offer fixed body sizes and ball counts. Established SMT mounting processes and techniques are compatible with ChipArray®. The package size and design provides ideal RF operation (low inductance) for high speed applications requiring small footprints.

ChipArray® Ball Grid Array

Part Description	I/O Count	Pitch	Body Size	Ball Matrix	Ball Alignment	Quantity per Tray	Available Lead Free Alloy
.8mm Pitch							
A-CABGA36-.8mm-6mm	36	.8mm	6mm	6x6	Full Array	608	SAC105, SAC305
A-CABGA100-.8mm-10mm	100	.8mm	10mm	10x10	Full Array	184/250	SAC105, SAC305
A-CABGA160-.8mm-12mm	160	.8mm	12mm	14x14	Perimeter	189	SAC105, SAC305
A-CABGA176-.8mm-13mm	176	.8mm	13mm	15x15	Perimeter	160	SAC105, SAC305
A-CABGA192-.8mm-14mm	192	.8mm	14mm	16x16	Perimeter	119	SAC105, SAC305
A-CABGA208-.8mm-15mm	208	.8mm	15mm	17x17	Perimeter	126	SAC105, SAC305
A-CABGA288-.8mm-19mm	288	.8mm	19mm	22x22	Perimeter	84	SAC105, SAC305
1.0mm Pitch							
A-CABGA196-1.0mm-15mm	196	1.0mm	15mm	14x14	Full Array	126	SAC105, SAC305
A-CABGA256-1.0mm-17mm	256	1.0mm	17mm	16x16	Full Array	90	SAC105, SAC305

Notes

- Parts are packaged in JEDEC trays
- All components are daisy-chained.
- <0.12mm (5 mil) coplanarity.
- BT (Bismaleimide-Triazine) substrates or equivalent.
- Package thickness is 1.5mm max for 0.8mm and 1.0mm pitch packages.
- Moisture sensitivity is JEDEC level 3.
- Lead free parts are available with 96.5%Sn/3.0%Ag/0.5%Cu alloy (SAC305) and 98.5%Sn/1.0%Ag/0.5%Cu alloy (SAC105).
- CABGA, CVBGA and CTBGA parts are available without solder balls, which makes the package LGA.

Part Description System

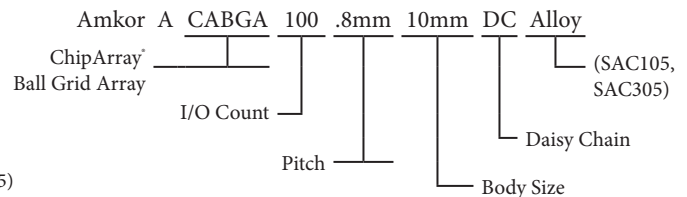

- Add "TR" to end of part description for Tape and Reel
- Add "SAC105" or "SAC305" to end of part description for Lead-Free.

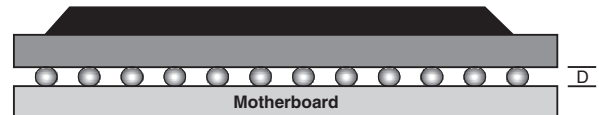
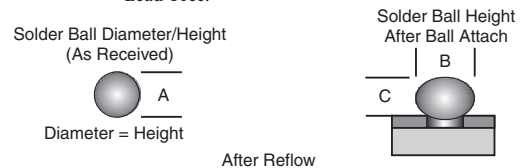

Package Pitch	A	B	C	D
1.00/0.80mm	0.46mm	0.48mm (± 0.05mm)	0.36mm (± 0.05mm)	0.30mm (± 0.05mm)

Note: Typical motherboard non-solder mask defined pad:

- 0.80 pitch = 0.30
- 1.00 pitch = 0.38



For recommended kits see pages 98, 112, 113



PBGA

Plastic Ball Grid Array



Amkor Plastic Ball Grid Arrays (PBGA) incorporate advanced assembly processes and designs for low cost, high performance applications. PBGAs are designed for low inductance, improved thermal operation and enhanced SMT ability.

Part Description	I/O Count	Pitch	Body Size	Ball Matrix	Ball Alignment	Quantity per Tray	Available Lead Free Alloy
1.0mm Pitch							
A-PBGA208-1.0mm-17mm	208	1.0mm	17mm	16x16	Perimeter	90	SAC305
A-PBGA256-1.0mm-17mm	256	1.0mm	17mm	16x16	Full Array	90	SAC305
A-PBGA324-1.0mm-19mm	324	1.0mm	19mm	18x18	Full Array	84	SAC305
A-PBGA324-1.0mm-23mm	324	1.0mm	23mm	22x22	Perimeter	60	SAC305
A-PBGA580-1.0mm-35mm	580	1.0mm	35mm	34x34	Perimeter	24	SAC305
A-PBGA676-1.0mm-27mm	676	1.0mm	27mm	26x26	Full Array	40	SAC305
A-PBGA680-1.0mm-35mm	680	1.0mm	35mm	34x34	Perimeter	24	SAC305
A-PBGA1156-1.0mm-35mm	1156	1.0mm	35mm	34x34	Full Array	24	SAC305
1.27mm Pitch							
A-PBGA208-1.27-23mm	208	1.27mm	23mm	17x17	Perimeter	60	SAC305
A-PBGA388-1.27mm-35mm	388	1.27mm	35mm	26x26	Perimeter	24	SAC305

Notes

- Parts are packaged in JEDEC trays.
- Moisture sensitivity is JEDEC level 3.
- JEDEC MS-034 standard outlines.
- All components are daisy-chained.
- Daisy-chained connections are connections between I/O (input/output) of the component.
- Lead-free parts are available with 96.5%Sn/3.0%Ag/0.5%Cu (SAC305) alloy.
- Eutectic 63/37 SnPb Solder ball material may be available. Please call.
- BGA packages should be baked at 125°C for 24 hours prior to assembly to prevent delamination during the assembly process.

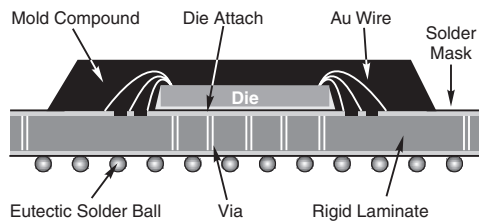

Part Description System

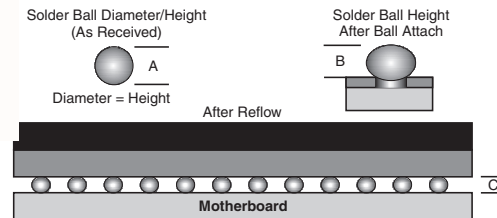
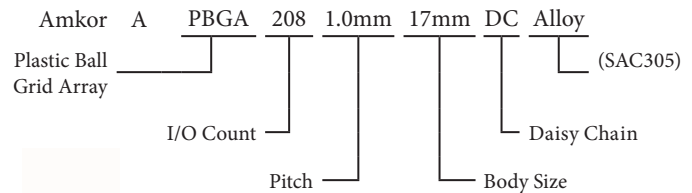

Package	Pitch	Solder Ball Diameter (A)	Solder Ball Land On Package and Board	Solder Ball Height on Package (B)	Solder Joint Height After SMT* (C)
⁽¹⁾ PBGA	1.00	0.50	0.45	0.40	0.32
⁽²⁾ PBGA	1.00	0.63	0.45	0.55	0.48
PBGA	1.27	0.76	0.63	0.60	0.52
PBGA	1.50	0.76	0.63	0.60	0.52

Units = mm

*Assumptions: 5 mils Solder Paste
Solder Mask Defined Pad

- Applies to 13, 15 and 17mm packages.
- Applies to 23, 27, 31, 35mm, and 40.0mm packages.



For recommended kits see pages, 96, 102, 111, 112, 113, 115, 123, 124.

Amkor laminate ChipArray[®] packages are available without solder balls upon special order. Packages available without solder balls include CABGA, CTBGA and CVBGA. The same standard daisy-chained substrate would be used based on open tooling.

LGA is another term used for parts without solder balls. The same BOM (bill of material) is used when parts are assembled. LGA parts are used to reduce package height, drop test performance in handheld applications, solder ball attach practice, socket insertion, P&P evaluation, reflow profiling, enhance thermal cycle reliability and other purposes.

LGA solder interconnect is formed solely by solder paste applied at board assembly because there are no solder balls attached to the LGA. This results in a lower stand-off height of approximately 0.06mm to 0.10mm, depending on solder paste volume and PCB geometry. Laminate substrate is solder mask defined. Standard ball pad finish is NiAu.

Application notes available for supporting technical data.



Notes

- Body sizes range from 5mm ~ 17mm.
- Available pitches are .4mm, .5mm, .8mm and 1.0mm.
- Parts packaged in trays (standard).
- Parts available on Tape and Reel upon special request.

Part Description System (example when ordering)

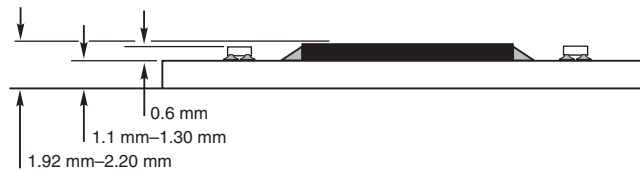
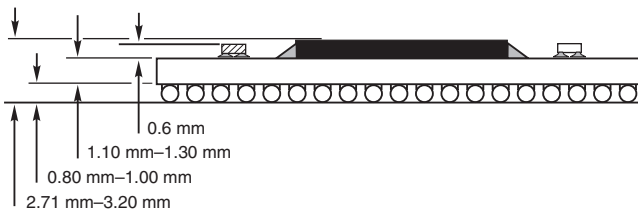
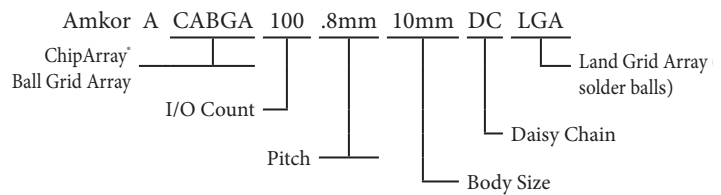

Unmounted device profile (with balls on left, LGA on right)

OmQFN

Open-molded Quad Flat Pack No Leads

From prototype to production volumes, these pre-molded QFN packages, created by Quick-Pak, provide a high quality, fast solution for your assembly needs.

The pre-molded packages come in a variety of sizes. They are available from 3x3mm to 12x12mm body size with lead pitch sizes ranging from .8mm to .4mm. Covers or lids are also available for air cavity applications.

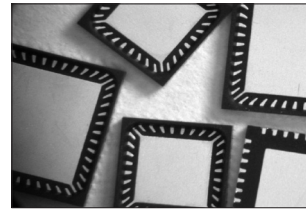

OmQFN Open-molded Quad Flat Pack No Leads Package

Part Description	Lead Count	Body Size	Pitch
.4mm Pitch			
QPQFN28-4mm-.4mm	28	4mm	.4mm
QPQFN48-6mm-.4mm	48	6mm	.4mm
QPQFN88-10mm-.4mm	88	10mm	.4mm
QPQFN100-12mm-.4mm	100	12mm	.4mm
.5mm Pitch			
QPQFN12-3mm-.5mm	12	3mm	.5mm
QPQFN16-3mm-.5mm	16	3mm	.5mm
QPQFN20-4mm-.5mm	20	4mm	.5mm
QPQFN24-4mm-.5mm	24	4mm	.5mm
QPQFN28-5mm-.5mm	28	5mm	.5mm
QPQFN32-5mm-.5mm	32	5mm	.5mm
QPQFN40-6mm-.5mm	40	6mm	.5mm
QPQFN44-7mm-.5mm	44	7mm	.5mm
QPQFN48-7mm-.5mm	48	7mm	.5mm
QPQFN56-8mm-.5mm	56	8mm	.5mm
QPQFN64-9mm-.5mm	64	9mm	.5mm
QPQFN72-10mm-.5mm	72	10mm	.5mm
QPQFN80-12mm-.5mm	80	12mm	.5mm
.65mm Pitch			
QPQFN12-3mm-.65mm	12	3mm	.65mm
QPQFN16-4mm-.65mm	16	4mm	.65mm
QPQFN20-5mm-.65mm	20	5mm	.65mm
QPQFN24-5mm-.65mm	24	5mm	.65mm
QPQFN28-6mm-.65mm	28	6mm	.65mm
QPQFN32-7mm-.65mm	32	7mm	.65mm

Notes

- Larger die paddle area.
- Supports larger die and ground bonds per given body size.
- RoHS and REACH compliant “green” molding compound.
- Gold plated.
- Superior bondability.
- Custom body sizes and lead counts available.
- Components can be encapsulated or lids are available.
- 40Au/80Ni Plated

Assembly Solutions Include the following:

- Wafer Dicing
- Wire Bonding
- Custom Packaging
- Backgrinding
- Complete Assembly



Part Description System

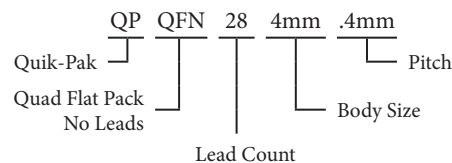



Amkor's MicroLeadFrame® Package (MLF®) is a near CSP plastic encapsulated package with a copper leadframe substrate. This package uses perimeter lands on the bottom of the package to provide electrical contact to the PWB. The package also offers

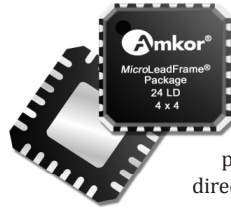

MLF® MicroLeadFrame®

Amkor's ExposedPad™ technology as a thermal enhancement by having the die attach paddle exposed on the bottom of the package surface to provide an efficient heat path when soldered directly to the PWB.

MLF® – MicroLeadFrame®

Part Description	Lead Count	Body Size	Pitch
.4mm Pitch			
A-MLF48-6mm-.4mm	48	6mm	.4mm
A-MLF88-10mm-.4mm	88	10mm	.4mm
A-MLF100-12mm-.4mm	100	12mm	.4mm
.5mm Pitch			
A-MLF16-3mm-.5mm	16	3mm	.5mm
A-MLF24-4mm-.5mm	24	4mm	.5mm
A-MLF32-5mm-.5mm	32	5mm	.5mm
A-MLF36-6mm-.5mm	36	6mm	.5mm
A-MLF40-6mm-.5mm	40	6mm	.5mm
A-MLF44-7mm-.5mm	44	7mm	.5mm
A-MLF48-7mm-.5mm	48	7mm	.5mm
A-MLF68-10mm-.5mm	68	10mm	.5mm
A-MLF72-10mm-.5mm	72	10mm	.5mm
.65mm Pitch			
A-MLF16-4mm-.65mm	16	4mm	.65mm
A-MLF32-7mm-.65mm	32	7mm	.65mm
A-MLF44-9mm-.65mm	44	9mm	.65mm
.8mm Pitch			
A-MLF16-5mm-.8mm	16	5mm	.8mm

Notes

- Parts are available in trays or on tape and reel upon special request.
- Solder plating finish available is 100% Matte Sn.
- Moisture sensitivity level is JEDEC 1.
- Small size (50% space reduction as compared with TSSOP).
- MLF package is a near CSP plastic encapsulated package with a copper leadframe substrate.
- MLF is also known as QFN, MCC or MLP.
- 0.6mm to 1.5mm maximum height
- Body sizes ranging from 3 x 3mm to 12 x 12mm.
- Pin counts and body sizes change on an ongoing basis. Please call for updated listing of available packages.

Part Description System

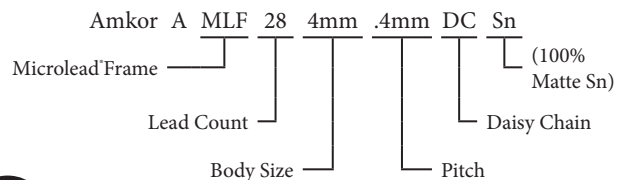

- Add "TR" to end of part number for Parts on Tape and Reel.
- Add "T" to end of part number for Parts in Trays.

Cross-Sections MLF®

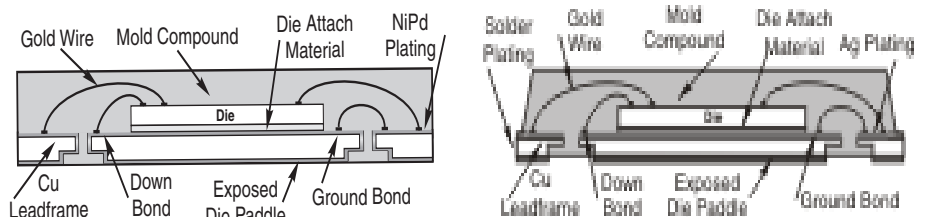

MAP Design "Saw"



For recommended kits see pages, 100, 102, 103, 109, 123, 125.

LQFP

Low Profile Quad Flat Pack



Low Profile Quad Flat Pack (LQFP) packages provide the same benefit of the metric QFP packages, but are thinner (body thickness of 1.4mm) and have a standard lead-frame footprint (2.0mm lead footprint).

LQFPs help to solve issues such as increasing board density, die shrink programs, thin end-product profile and portability. Lead counts range from 32 to 256. Body sizes range from 7 x 7mm to 28 x 28mm. Copper lead-frames are used for the LQFP package.

Daisy-Chain Parts Available!



LQFP Low Profile Quad Flat Pack 1.4mm Thick

Part Description	Number of Pins	Body Size	Lead Pitch	Quantity Per Tray	Tape Width	Tape Pitch	Quantity Per Reel
.4mm Pitch							
A-LQFP64-7mm-.4mm-2.0	64	17mm sq	.4mm	250	16mm	12mm	1,000
A-LQFP120-14mm-.5mm-2.0	120	14mm sq	.4mm	90	32mm	24mm	750
A-LQFP128-14mm-.4mm-2.0	128	14mm sq	.4mm	90	32mm	24mm	750
A-LQFP176-20mm-.5mm-2.0	176	20mm sq	.4mm	60	44mm	24mm	500
A-LQFP216-24mm-.4mm-2.0	216	24mm sq	.4mm	40	44mm	32mm	500
A-LQFP256-28mm-.4mm-2.0	256	28mm sq	.4mm	36	44mm	40mm	500
.5mm Pitch							
A-LQFP48-7mm-.5mm-2.0	48	7mm sq	.5mm	250	16mm	12mm	1,000
A-LQFP64-10mm-.5mm-2.0	64	10mm sq	.5mm	160	24mm	24mm	1,000
A-LQFP100-14mm-.5mm-2.0	100	14mm sq	.5mm	90	32mm	24mm	750
A-LQFP128-14x20-.5mm-2.0	128	14x20mm	.5mm	72	44mm	32mm	500
A-LQFP128-20mm-.5mm-2.0	128	20mm sq	.5mm	60	44mm	24mm	500
A-LQFP144-20mm-.5mm-2.0	144	20mm sq	.5mm	60	44mm	24mm	750
A-LQFP160-24mm-.5mm-2.0	160	24mm sq	.5mm	40	44mm	32mm	500
A-LQFP176-24mm-.5mm-2.0	176	24mm sq	.5mm	40	44mm	32mm	500
A-LQFP208-28mm-.5mm-2.0	208	28mm sq	.5mm	36	44mm	40mm	500
.65mm Pitch							
A-LQFP52-10mm-.65mm-2.0	52	10mm sq	.65mm	160	24mm	24mm	1,000
A-LQFP80-14mm-.65mm-2.0	80	14mm sq	.65mm	90	32mm	24mm	750
A-LQFP100-14x20-.65mm-2.0	100	14x20mm	.65mm	72	44mm	32mm	500
.8mm Pitch							
A-LQFP32-7mm-.8mm-2.0	32	7mm sq	.8mm	250	16mm	12mm	1,000
A-LQFP44-10mm-.8mm-2.0	44	10mm sq	.8mm	160	24mm	24mm	1,000
A-LQFP64-14mm-.8mm-2.0	64	14mm sq	.8mm	90	32mm	24mm	750

Notes

- All LQFPs are standard in trays.
- Parts available on Tape and Reel.
- LQFPs have a body thickness of 1.4mm.
- Moisture sensitivity is JEDEC level 3.
- Lead-free parts are available with 100% Matte Sn finish.
- SnPb parts no longer available.

Part Description System

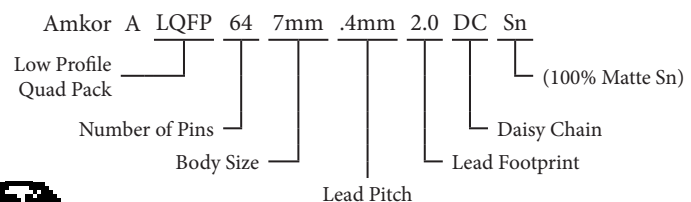

- Add "TR" to end of part number for Tape and Reel.
- Add "SN" to end of part number for Lead Free parts.



For recommended kits see pages 109, 111, 118, 119, 123, 124.



For drawings, please visit our web site at www.TrustPCI.com.

Thin Quad Flat Pack (TQFP) packages provide the same benefit of the metric QFP package, but are thinner (body thickness of 1.0mm) and have a standard lead-frame footprint (2.0mm lead footprint). TQFPs are helping to solve issues such as increasing board density, die shrink programs, thin end-product profile and portability. Lead counts range from 32 to 176. Body sizes range from 5 x 5mm to 20 x 20mm. Copper lead-frames are used for the TQFP package.

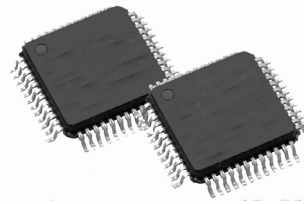

TQFP Thin Quad Flat Pack 1.0mm Thick

Part Description	Number of Pins	Body Size	Lead Pitch	Quantity Per Tray	Tape Width	Tape Pitch	Quantity Per Reel
.4mm Pitch							
A-TQFP40-5mm-.4mm-2.0	40	5mm sq	.4mm	360	16mm	12mm	1,000
A-TQFP64-7mm-.4mm-2.0	64	7mm sq	.4mm	250	16mm	12mm	1,000
A-TQFP120-14mm-.4mm-2.0	120	14mm sq	.4mm	90	32mm	24mm	750
A-TQFP128-14mm-.4mm-2.0	128	14mm sq	.4mm	90	32mm	24mm	750
A-TQFP176-20mm-.4mm-2.0	176	20mm sq	.4mm	60	44mm	24mm	500
.5mm Pitch							
A-TQFP32-5mm-.5mm-2.0	32	5mm sq	.5mm	360	16mm	12mm	1,000
A-TQFP48-7mm-.5mm-2.0	48	7mm sq	.5mm	250	16mm	12mm	1,000
A-TQFP64-10mm-.5mm-2.0	64	10mm sq	.5mm	160	24mm	16mm	1,000
A-TQFP80-12mm-.5mm-2.0	80	12mm sq	.5mm	119	24mm	24mm	1,000
A-TQFP100-14mm-.5mm-2.0	100	14mm sq	.5mm	90	32mm	24mm	750
A-TQFP128-20mm-.5mm-2.0	128	20mm sq	.5mm	60	44mm	24mm	500
A-TQFP144-20mm-.5mm-2.0	144	20mm sq	.5mm	60	44mm	24mm	500
.65mm Pitch							
A-TQFP80-14mm-.65mm-2.0	80	14mm sq	.65mm	90	32mm	24mm	750
.8mm Pitch							
A-TQFP32-7mm-.8mm-2.0	32	7mm sq	.8mm	250	16mm	12mm	1,000
A-TQFP44-10mm-.8mm-2.0	44	10mm sq	.8mm	160	24mm	16mm	1,000
A-TQFP52-10mm-.8mm-2.0	52	10mm sq	.8mm	160	24mm	16mm	1,000
A-TQFP64-14mm-.8mm-2.0	64	14mm sq	.8mm	90	32mm	24mm	750

Notes

- All TQFP are standard in trays.
- Parts available on Tape and Reel.
- TQFP have body thickness of 1.0mm.
- Moisture sensitivity is JEDEC level 3.
- Lead-free parts are available with 100% Matte Sn finish.
- SnPb parts no longer available.

Part Description System

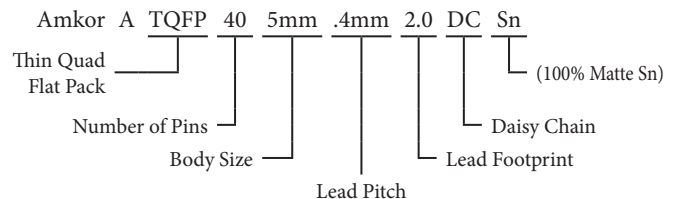

- Add "TR" to end of part number for Tape and Reel.
- Add "SN" to end of part number for Lead-Free parts.

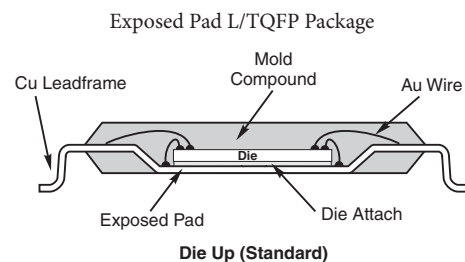
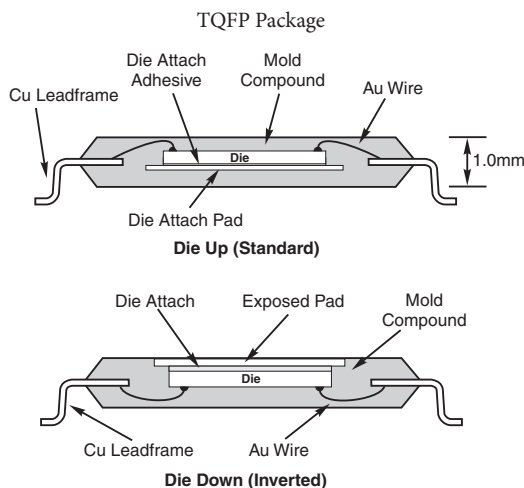

For recommended kit see page 98, 102, 109.

QFP

Quad Flat Pack



Quad Flat Pack (QFP) components have four sides with leads extending from the component body on all four sides. QFP components come packaged in trays or on tape and reel to protect the component leads that can be easily damaged. An important measurement for QFPs is coplanarity.

When the first lead from the component is placed on the PCB coplanarity is established. Coplanarity ensures the last lead can be placed on the board. The standard for QFP coplanarity is ± 4 mils.

QFP Quad Flat Pack

Part Description	Number of Pins	Body Size	Body Thickness	Lead Pitch	Footprint	Quantity Per Tray	Tape Width	Tape Pitch	Quantity Per Reel
.5mm Pitch									
A-QFP64-10mm-.5mm-3.2	64	10mm sq	2.0mm	.5mm	3.2mm	96	24	24	500
A-QFP64-10mm-.5mm-3.9	64	10mm sq	2.0mm	.5mm	3.9mm	96	24	24	500
A-QFP100-14mm-.5mm-3.2	100	14mm sq	2.0/2.67mm	.5mm	3.2mm	84	32	24	350
A-QFP100-14mm-.5mm-3.9	100	14mm sq	2.67mm	.5mm	3.9mm	84	32	24	350
A-QFP128-14x20mm-.5mm-3.2	128	14x20mm	2.71mm	.5mm	3.2mm	66	44	32	200
A-QFP128-14x20mm-.5mm-3.2	128	14x20mm	2.71mm	.5mm	3.9mm	66	44	32	200
A-QFP208-28mm-.5mm-2.6	208	28mm sq	3.37mm	.5mm	2.6mm	24	44	40	200
A-QFP208-28mm-.5mm-3.2	208	28mm sq	3.37mm	.5mm	3.2mm	24	44	40	200
A-QFP240-32mm-.5mm-2.6	240	32mm sq	3.4mm	.5mm	2.6mm	24	56	44	250
.65mm Pitch									
A-QFP52-10mm-.65mm-3.2	52	10mm sq	2.0mm	.65mm	3.2mm	96	24	24	500
A-QFP52-10mm-.65mm-3.9	52	10mm sq	2.0mm	.65mm	3.9mm	96	24	24	500
A-QFP80-14mm-.65mm-3.2	80	14mm sq	2.0/2.67mm	.65mm	3.2mm	84	32	24	350
A-QFP80-14mm-.65mm-3.9	80	14mm sq	2.67mm	.65mm	3.9mm	84	32	24	350
A-QFP100-14x20mm-.65mm-3.2	100	14x20mm	2.71mm	.65mm	3.2mm	66	44	32	200
A-QFP100-14x20mm-.65mm-3.9	100	14x20mm	2.71mm	.65mm	3.9mm	66	44	32	200
A-QFP144-28mm-.65mm-3.2	144	28mm sq	3.37mm	.65mm	3.2mm	24	44	40	200
A-QFP144-28mm-.65mm-3.9	144	28mm sq	3.37mm	.65mm	3.9mm	24	44	40	200
A-QFP160-28mm-.65mm-2.6	160	28mm sq	3.37mm	.65mm	2.6mm	24	44	40	200
A-QFP160-28mm-.65mm-3.2	160	28mm sq	3.37mm	.65mm	3.2mm	24	44	40	200
A-QFP160-28mm-.65mm-3.9	160	28mm sq	3.37mm	.65mm	3.9mm	24	44	40	200
.8mm Pitch									
A-QFP44-10mm-.8mm-3.2	44	10mm sq	2.0mm	.8mm	3.2mm	96	24	24	500
A-QFP44-10mm-.8mm-3.9	44	10mm sq	2.0mm	.8mm	3.9mm	96	24	24	500
A-QFP64-14mm-.8mm-3.2	64	14mm sq	2.0/2.67mm	.8mm	3.2mm	84	32	24	350
A-QFP64-14mm-.8mm-3.9	64	14mm sq	2.67mm	.8mm	3.9mm	84	32	24	350
A-QFP80-14x20mm-.8mm-3.2	80	14x20mm	2.71mm	.8mm	3.2mm	66	44	32	200
A-QFP80-14x20mm-.8mm-3.9	80	14x20mm	2.71mm	.8mm	3.9mm	66	44	32	200
A-QFP120-28mm-.8mm-2.6	120	28mm sq	3.37mm	.8mm	2.6mm	24	44	40	200
A-QFP120-28mm-.8mm-3.2	120	28mm sq	3.37mm	.8mm	3.2mm	24	44	40	200
A-QFP128-28mm-.8mm-2.6	128	28mm sq	3.37mm	.8mm	2.6mm	24	44	40	200
A-QFP128-28mm-.8mm-3.2	128	28mm sq	3.37mm	.8mm	3.2mm	24	44	40	200
1.00mm Pitch									
A-QFP52-14mm-1.0mm-3.2	52	14mm sq	2.0/2.67mm	1.00mm	3.2mm	84	32	24	350
A-QFP52-14mm-1.0mm-3.9	52	14mm sq	2.67mm	1.00mm	3.9mm	84	32	24	350
A-QFP64-14x20-1.0mm-3.2	64	14x20mm	2.71mm	1.00mm	3.2mm	66	44	32	200
A-QFP64-14x20-1.0mm-3.9	64	14x20mm	2.71mm	1.00mm	3.9mm	66	44	32	200

Notes

- All QFPs are standard in JEDEC trays.
- Tray quantities may vary.
- Parts available on Tape and Reel.
- Lead-free parts are available with 100% Matte Sn finish.

Part Description System

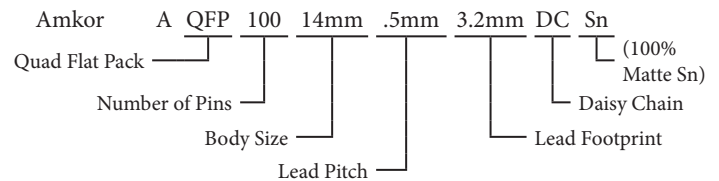

- Add "TR" to end of part number for Tape and Reel.



For kits see pages, 97, 98, 107, 111, 112, 118, 123, 124.

The standard daisy chain pattern for non-BGA IC's is Even. Example of daisy-chain "even" pattern for leadframe packages. Pin 1-2, 3-4, 5-6, 7-8, etc. Continuity testing requires dummy components to contain daisy-chain connections. There is no standard daisy-chain pattern for Ball Grid Array Packages.

QFP Quad Flat Packs

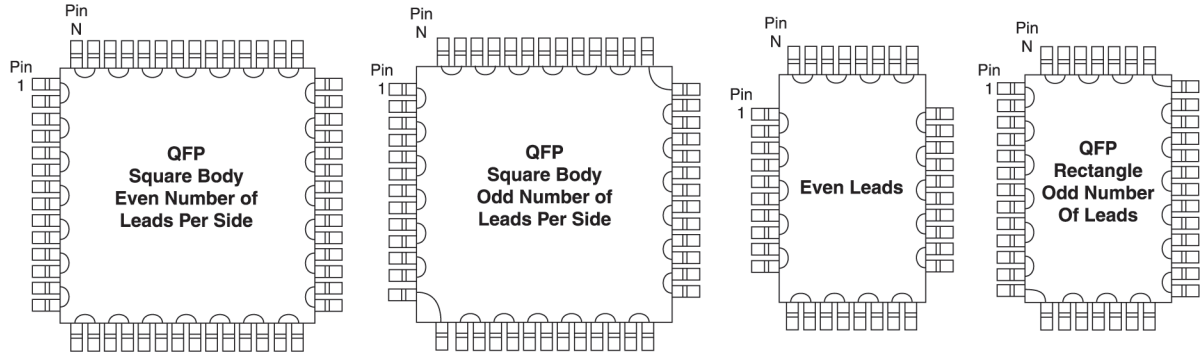

SOIC Small Outline Integrated Circuits

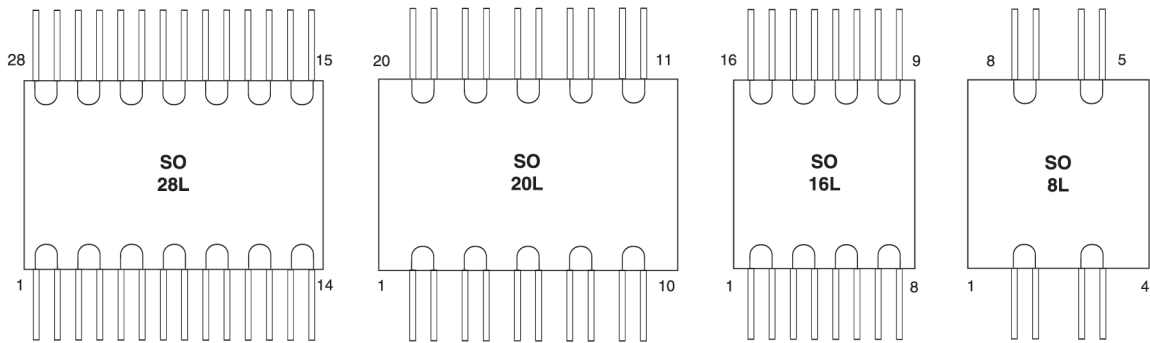

PLCC Plastic Leaded Chip Carriers

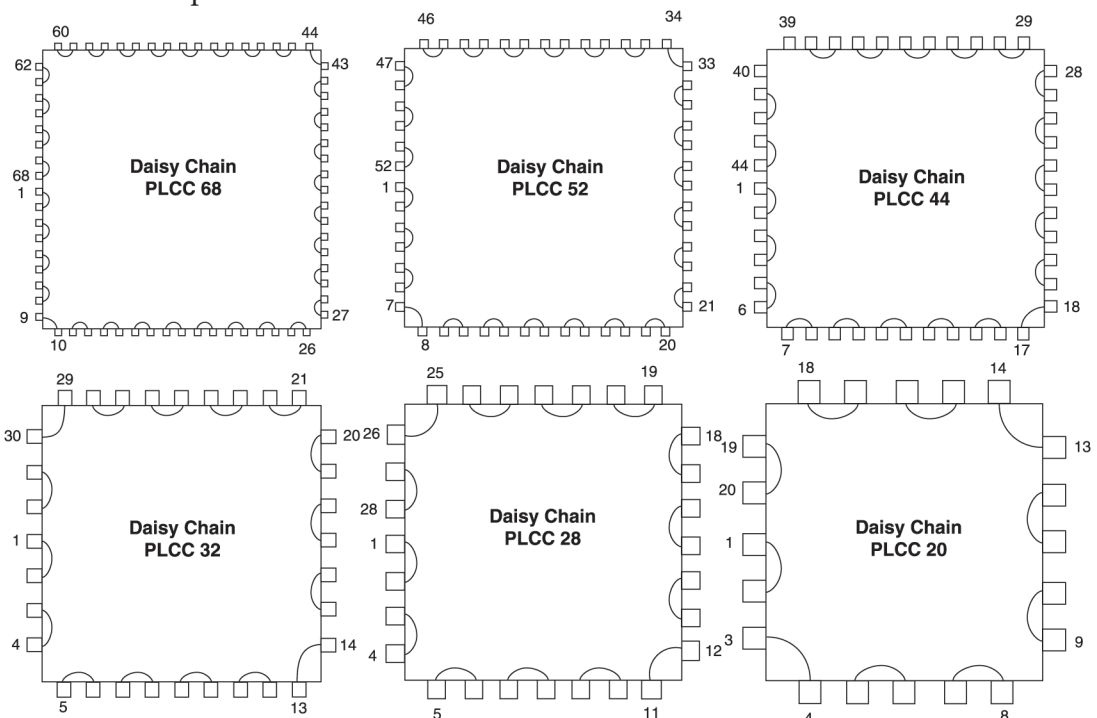

Plastic Leded Chip Carrier

Plastic Leded Chip Carriers (PLCC) are four-sided “J” Leded Plastic body packages. Lead counts range from 20 to 84. PLCC packages can be square or rectangle. Body sizes range from .35” to 1.15”. PLCCs are JEDEC

standard compliant. The PLCC “J” Lead configuration requires less board space versus equivalent gull leded components.

PLCC Plastic Leded Chip Carrier

Part Description	Lead Count	Body Size	Quantity Per Tube	Tape Width	Tape Pitch	Quantity Per Reel
PLCC20T	20	8.8mm	46	16mm	12mm	1,000
PLCC28T	28	11.4mm	38	24mm	16mm	750
PLCC32T	32	11.4x13mm	30	24mm	16mm	750
PLCC44T	44	16.5mm	27	32mm	24mm	450/500
PLCC68T	68	24.1mm	18	44mm	32mm	230/250
PLCC84T	84	29.2mm	15	44mm	36mm	250

Notes

- All PLCCs have “J” leads.
- Standard lead pitch is 1.27mm (50 mils).
- PLCCs are to JEDEC standards.
- Tube quantity may vary.
- Parts available on Tape and Reel.
- Moisture sensitivity is JEDEC level 3.
- Lead-free parts are available with 100% Matte Sn finish.
- Daisy-Chained and Lead-Free parts available.



Part Description System

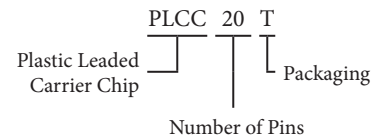

- Packaging: T=Tubes, TR=Tape and Reel.
- Add “Sn” to end of part number for Lead-Free.

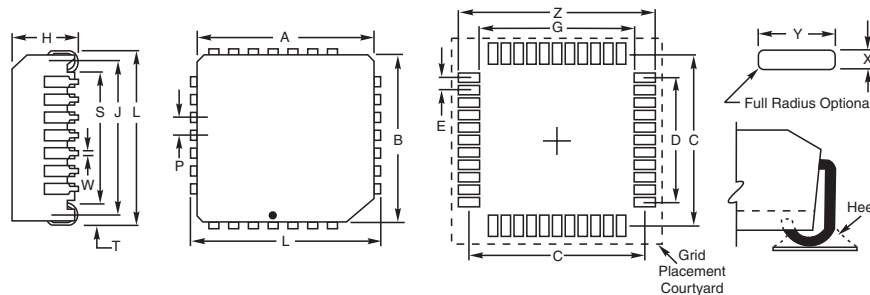

PLCC Component Dimensions

Component Identifier	L (mm)		S (mm)		W (mm)		T (mm)		A (mm)		B (mm)		J (mm)	H (mm)	P (mm)
	Min	Max	Min	Max	Min	Max	Min	Max	Min	Max	Min	Max	Ref	Max	Basic
PLCC-20	9.78	10.03	5.78	6.53	0.33	0.53	1.50	2.00	8.89	9.04	8.89	9.04	7.87	4.57	1.27
PLCC-28	12.32	12.57	8.32	9.07	0.33	0.53	1.50	2.00	11.43	11.58	11.43	11.58	10.41	4.57	1.27
PLCC-44	17.40	17.65	13.40	14.15	0.33	0.53	1.50	2.00	16.51	16.66	16.51	16.66	15.49	4.57	1.27
PLCC-68	25.02	25.27	21.02	21.77	0.33	0.53	1.50	2.00	24.13	24.33	24.13	24.33	23.11	5.08	1.27
PLCC-84	30.10	30.35	26.10	26.85	0.33	0.53	1.50	2.00	29.21	29.41	29.21	29.41	28.19	5.08	1.27

PLCC Land Patterns

Component Identifier	Z (mm)	G (mm)	X (mm)	Y (mm) Ref	C (mm) Ref	D (mm) Ref	E (mm) Ref	Placement Grid (No. of Elements)
PLCC-20	10.80	6.40	0.60	2.20	8.60	5.08	1.27	24 x 24
PLCC-28	13.40	9.00	0.60	2.20	11.20	7.62	1.27	30 x 30
PLCC-44	18.40	14.00	0.60	2.20	16.20	12.70	1.27	40 x 40
PLCC-68	26.00	21.60	0.60	2.20	23.80	20.32	1.27	54 x 54
PLCC-84	31.20	26.80	0.60	2.20	29.00	25.40	1.27	66 x 66



For kits see pages 97, 107, 111, 112, 118, 119, 123.

Small Outline Package (SOIC) body size was compressed and the lead pitch tightened to obtain a smaller version SOIC. This yields an IC package

that is a significant reduction in the size (compared to standard package). All IC assembly processes remain the same as with our standard SOICs.

SOIC Small Outline Integrated Circuit

Part Description	Number of Pins	Body Size	Quantity Per Tube	Tape Width	Tape Pitch	Quantity Per Reel
SO8GT-3.8mm	8	3.8mm	100	12mm	8mm	2,500
SO14GT-3.8mm	14	3.8mm	50	16mm	8mm	2,500
SO16GT-3.8mm	16	3.8mm	48	16mm	8mm	2,500
SO16GT-7.6mm	16	7.6mm	46	16mm	12mm	1,000
SO20GT-7.6mm	20	7.6mm	38	24mm	12mm	1,000
SO24GT-7.6mm	24	7.6mm	31	16mm	12mm	1,000
SO28GT-7.6mm	28	7.6mm	25	24mm	12mm	1,000

Notes

- Standard lead pitch is 1.27mm.
- Tube quantity may vary.
- Parts available on Tape and Reel.
- Lead-free parts are available with 100% Matte Sn finish.



For kits see pages 97, 98, 107, 111, 112, 116, 118, 119, 124.



Part Description

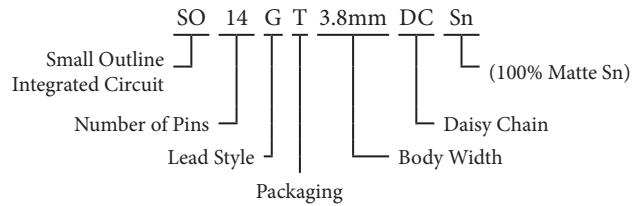

- Lead Style: G=Gull Wing.
- Packaging: T=Tubes, TR=Tape and Reel.
- Add "Sn" to end of part number for Lead-Free.

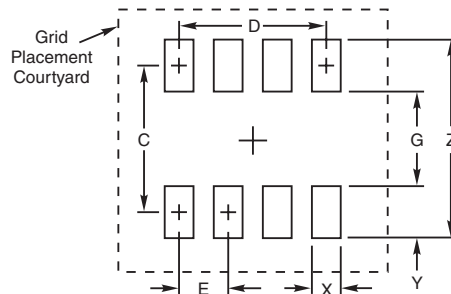
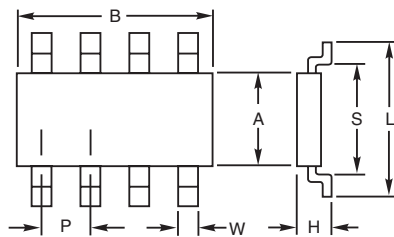

SOIC Component Dimensions

Component Identifier	JEDEC Number	L (mm)		S (mm)		W (mm)		T (mm)		A (mm)		B (mm)		H (mm)		P (mm)
		Min	Max	Min	Max	Min	Max	Min	Max	Min	Max	Min	Max	Min	Max	Basic
SO8	MS-012 AA	5.80	6.30	3.26	4.55	0.33	0.51	0.40	1.27	3.80	4.00	4.80	5.00	1.35	1.75	1.27
SO14	MS-012 AB	5.80	6.30	3.26	4.55	0.33	0.51	0.40	1.27	3.80	4.00	8.55	8.75	1.35	1.75	1.27
SO16	MS-012 AC	5.80	6.30	3.26	4.55	0.33	0.51	0.40	1.27	3.80	4.00	9.80	10.00	1.35	1.75	1.27
SO16-7.6mm	MS-013 AA	10.00	10.65	7.46	8.85	0.33	0.51	0.40	1.27	7.40	7.60	10.10	10.50	2.35	2.65	1.27
SO20-7.6mm	MS-013 AC	10.00	10.65	7.46	8.85	0.33	0.51	0.40	1.27	7.40	7.60	12.60	13.00	2.35	2.65	1.27
SO28-7.6mm	MO-119 AB	10.29	10.64	8.21	9.01	0.36	0.51	0.53	1.04	7.40	7.60	18.08	18.39	2.34	2.64	1.27

SOIC Land Pattern Dimensions

Component Identifier	Z (mm)	G (mm)	X (mm)	Y (mm) Ref	C (mm) Ref	D (mm) Ref	E (mm) Ref	Placement Grid (No. of Grid Elements)
SO8	7.40	3.00	0.60	2.20	5.20	3.81	1.27	12 x 16
SO14	7.40	3.00	0.60	2.20	5.20	7.62	1.27	20 x 16
SO16	7.40	3.00	0.60	2.20	5.20	8.89	1.27	22 x 16
SO16-7.6mm	11.40	7.00	0.60	2.20	9.20	8.89	1.27	22 x 22
SO20-7.6mm	11.40	7.00	0.60	2.20	9.20	11.43	1.27	28 x 24
SO28-7.6mm	11.40	7.00	0.60	2.20	9.20	16.51	1.27	38 x 24

PDIP

Plastic Dual In-Line Package

Plastic Dual In-Line Packages (PDIP) are long-established industry standard through-hole packages.

PDIP Plastic Dual In-Line Package

Part Description	Number of Pins	Body Size (L)	Body Size (W)	Quantity Per Tube
PDIP8-300	8	.360"	.300"	50
PDIP14-300	14	.750"	.300"	25
PDIP16-300	16	.750"	.300"	25
PDIP18-300	18	.900"	.300"	21
PDIP20-300	20	1.030"	.300"	18
PDIP24-300	24	1.250"	.300"	15

Notes

- High conductivity copper leadframe.
- JEDEC standard compliant.
- Parts packaged in anti-static 20" tubes.
- Pitch is 100 mils.
- Lead-free available with 100% Sn Matte alloy.
- Eutectic solder plating finish is 85% Sn/15% Pb.

Part Description System

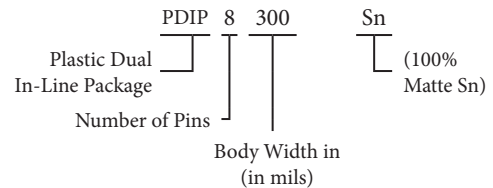
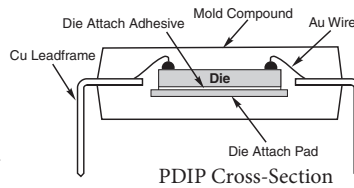

For kits see pages 102, 107, 112, 116, 118, 119, 123, 124.



Through-Hole Glass Diodes

Axial Leaded Through-hole Glass Diode package has been in use for over 50 years in the electronics industry. The body of these parts are glass and the package is hermetically sealed. The "DO" prefix is a JEDEC designation

for through-hole diodes. The 34 and 35 references case size. These type of components are packaged on ammo pack or bulk. In most cases, these parts are sold as training aids to teach new operators how to solder.

Axial Leaded Through-Hole Glass Diode

Part Description	References (JEDEC)	(EIAJ)	Case Size (Inch)	Case Size (mm)	Lead Diameter
DO-34	DO-34		0.0629"x0.1197"	1.6x3.04mm	.55mm
DO-35	DO-35	SC-40	0.0728"x0.1673"	1.85x4.25mm	.56mm

Notes

- Part is hermetically sealed glass package.
- Axial leaded (2 leads).
- Parts are packaged Ammo pack (5K per reel) or bulk.
- Lead-free available with 100% Sn alloy.

Part Description System

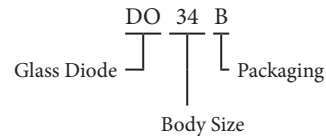

DO-34

Unit	b Max	D Max	G1Max	L Min
mm	0.55	1.6	3.04	25.4

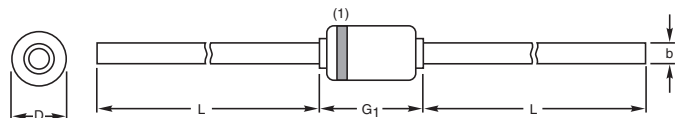

DO-35

Unit	b Max	D Max	G1Max	L Min
mm	0.56	1.85	4.25	25.4

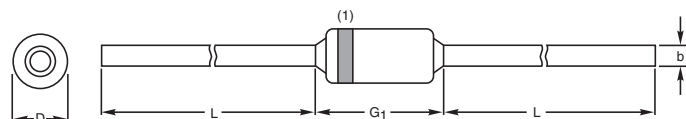

The Shrink Small Outline Package (SSOP) body size is compressed and the lead pitch is tightened to obtain a small version of the standard SOIC packages. Lead counts range from 8 to 64. Body sizes are 209 and 300 mils. The SSOP package is JEDEC and EIAJ compliant. The package leads are solder plated.

SSOP Shrink Small Outline Package

Part Description	Number of Pins	Body Size	Lead Pitch	Quantity Per Tube	Tape Width	Tape Pitch	Quantity Per Reel
A-SSOP14T-5.3mm	14	5.3mm	.65mm	100	16mm	12mm	1,000
A-SSOP16T-5.3mm	16	5.3mm	.65mm	80	16mm	12mm	1,000
A-SSOP20T-5.3mm	20	5.3mm	.65mm	62	16mm	12mm	1,000
A-SSOP24T-5.3mm	24	5.3mm	.65mm	66	16mm	12mm	1,000
A-SSOP28T-5.3mm	28	5.3mm	.65mm	47	16/24mm	12mm	1,000
A-SSOP36T-7.6mm	36	7.6mm	.8mm	31	24mm	12mm	1,000
A-SSOP48T-7.6mm	48	7.6mm	.635mm	30	32mm	12mm/16mm	1,000
A-SSOP56T-7.6mm	56	7.6mm	.635mm	26	32mm	12mm/16mm	500

Notes

- Tube quantity may vary.
- Parts available on Tape and Reel.
- 209 and 300 mil body widths.
- JEDEC and EIAJ package outline standard compliance.
- High-conductivity copper leadframes.
- Moisture sensitivity is JEDEC level 3.
- Lead-free available with 100% Matte Sn alloy.

Part Description System

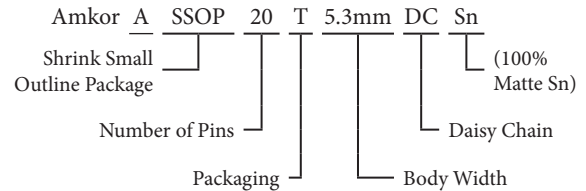

- Packaging: "T" = Tubes, "TR" = Tape and Reel.
- Add "Sn" to end of part number for Lead-Free.

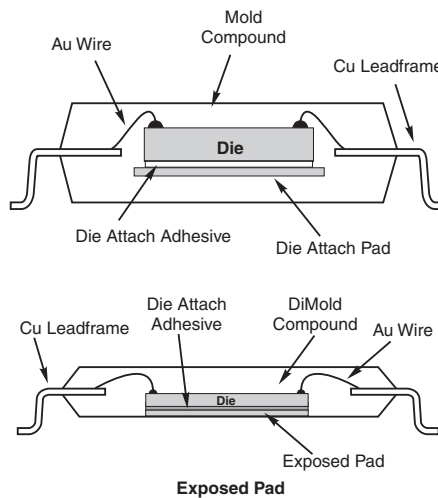

Note: Drawings not to scale.



For kits see page 111, 123, 124.

Practical Components is the exclusive distributor of Amkor Technology Mechanical Components.



Looking for Lead-Free?

This symbol indicates that lead-free parts are available!

TSSOP

Thin Shrink Small Outline Package



The Thin Shrink Small Outline Package (TSSOP) offers smaller body sizes, smaller lead pitches and package thickness (0.9mm thick) than standard SOIC packages. Body widths are 3.0mm, 4.4mm and 6.1mm. Lead counts range from 8 to 80. This package conforms to JEDEC package outlines.



TSSOP Thin Shrink Small Outline Package

Part Description	Number of Pins	Body Size	Lead Pitch	Quantity Per Tube	Tape Width	Tape Pitch	Quantity Per Reel
A-TSSOP8T-3.0mm	8	3.0mm	.65mm	98	12mm	8mm	2,500
A-TSSOP8T-4.4mm	8	4.4mm	.65mm	100	12/16mm	8mm	1,000/2,500
A-TSSOP10T-3.0mm	10	3.0mm	.5mm	98	12mm	8mm	2,500
A-TSSOP14T-4.4mm	14	4.4mm	.65mm	96	12/16mm	8mm	1,000/2,500
A-TSSOP16T-4.4mm	16	4.4mm	.65mm	96	12/16mm	8mm	1,000/2,500
A-TSSOP20T-4.4mm	20	4.4mm	.65mm	74	16mm	8/12mm	1,000/2,500
A-TSSOP24T-4.4mm	24	4.4mm	.65mm	62	16mm	8/12mm	1,000/2,500
A-TSSOP28T-4.4mm	28	4.4mm	.65mm	50	16mm	8/12mm	1,000
A-TSSOP44T-4.4mm	44	4.4mm	.5mm	42	24mm	12mm	1,000
A-TSSOP48T-6.1mm	48	6.1mm	.5mm	39	24mm	12mm	1,000
A-TSSOP56T-4.4mm	56	4.4mm	.4mm	42	24mm	12mm	1,000
A-TSSOP56T-6.1mm	56	6.1mm	.5mm	35	24mm	12mm	1,000
A-TSSOP80T-6.1mm	80	6.1mm	.4mm	28	N/A	N/A	N/A

Notes

- Tube quantity may vary.
- Parts available on Tape and Reel.
- 0.9mm body thickness for 4.4 and 6.1mm body widths.
- 0.85mm body thickness for 3.0mm body width.
- JEDEC package outline is standard.
- High conductivity copper leadframes.
- Very low-stress mold compound.
- Lead-free available with 100% Matte Sn alloy.

Part Description System

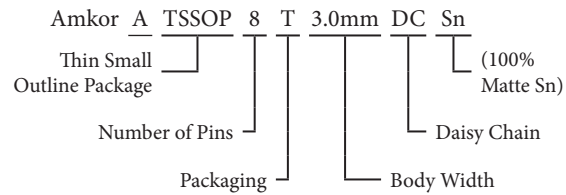

- Packaging: "T" = Tubes, "TR" = Tape and Reel.
- Add "Sn" to end of part number for Lead-Free.

TSSOP Package

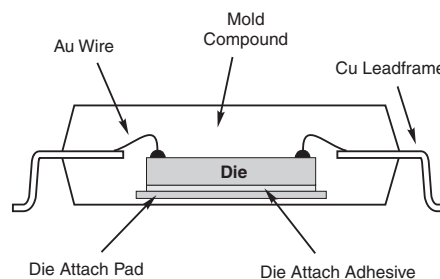

For recommended kit see page 107.

Thin Small Outline Packages (TSOP) are thin body size components; thickness is 1.0mm. TSOP packages have four sides and are rectangular. Type I TSOPs have the leads protruding from the width portion of the package. Lead counts range from 28 to 48. Package body size ranges from 8x11.8mm to 12x20mm.



TSOP Thin Small Outline Package – Type I

Part Description	Number of Pins	Body Size	Lead Pitch	Quantity Per Tray	Tape Width	Tape Pitch	Quantity Per Reel
A-T1-TSOP28-8.1x11.8mm-.55mm	28	8.1x11.8mm	.55mm	234	24mm	12mm	1,000
A-T1-TSOP32-8x11.8mm-.5mm	32	8x11.8mm	.5mm	234	24mm	12mm	1,000
A-T1-TSOP32-8x18.4mm-.5mm	32	8x18.4mm	.5mm	156	32mm	12/16mm	1,000
A-T1-TSOP48-12x18.4mm-.5mm	48	12x18.4mm	.5mm	96	32mm	16mm	1,000

Notes

- Standard packaging is in JEDEC trays.
- Body dimensions are measured by body length and width.
- Type I means that pins extend from the narrow end (the width) of the body.
- Parts available on Tape and Reel.
- Type II means that pins extend from the wide end (the length) of the body. Type II TSOP are becoming obsolete. Practical has some stock. Please call for availability.

Part Description System

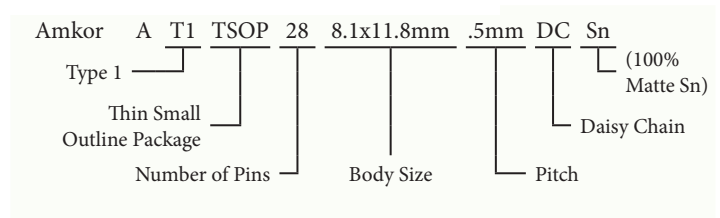

- Add "TR" to end of part number for Tape and Reel.

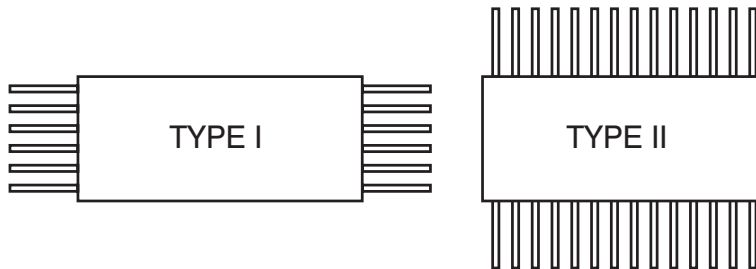

TSOP Thin Small Outline Package – Type II

Type II TSOP are becoming obsolete. Practical has some stock. Please call for availability.



Surface Mount Multilayer Ceramic (SMC) capacitors come in case sizes ranging from 01005 to 2225. The most popular case sizes are listed in the table below. Parts on tape and reel are available on paper tape or

plastic tape. Larger size reels are available upon special request. Practical Components has lead-free PCB test boards available for the 01005 through 1206 case sizes.

SMC Surface Mount Ceramic Capacitors

Part Description	Body Size (inch)	Body Size (mm)	Tape Width	Tape Pitch	Quantity Per Reel
01005SMC-PA-Sn	.01"x.005"	0.4x0.2mm	8mm	2mm	20,000
0201SMC-PA-Sn	.02"x.01"	0.6x0.3mm	8mm	2mm	15,000
0402SMC-PA-Sn	.04"x.02"	1.0x0.5mm	8mm	2mm	10,000
0603SMC-PA-Sn	.06"x.03"	1.6x0.8mm	8mm	4mm	4,000
0805SMC-PA-Sn	.08"x.05"	2.0x1.27mm	8mm	4mm	4,000
1206SMC-PA-Sn	.12"x.06"	3.2x1.6mm	8mm	4mm	4,000
1210SMC-PA-Sn	.12"x.10"	3.2x2.6mm	8mm	4mm	4,000
1812SMC-PL-Sn	.18"x.12"	4.5x3.2mm	12mm	8mm	1,000/1,100
1825SMC-PL-Sn	.18"x.25"	4.5x6.4mm	12mm	8mm	1,000/1,100

Notes

- Surface mount capacitors come on standard 7" reels (larger quantity reels are available upon request).
- Plastic carrier tape is non-standard for some carrier sizes.
- The numeric section of the part number refers to the physical body size (in inches) of the component. For example: Part number 0805SMC-PL has a body size of .08" length by .05" width.
- Chip capacitor arrays are available. Call for details.
- Capacitors are now only available standard lead-free with 100% Sn over Ni. SnPb is available upon request based on availability.

Part Description System

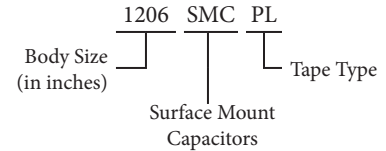

- Tape Type: PA = Paper Tape, PL = Plastic Tape

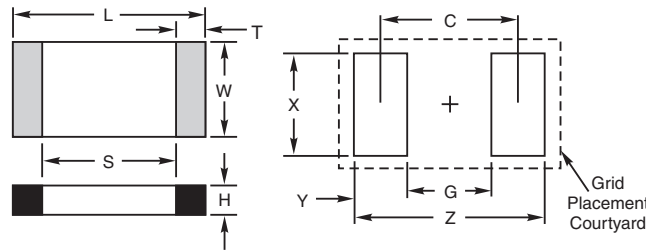

For kits see pages 98, 100, 103, 117, 119.

SMC Component Dimensions

Component Dimensions (mm) (in)	L (mm)		S (mm)		W (mm)		T (mm)		H (mm) Max
	Min	Max	Min	Max	Min	Max	Min	Max	
0603 (0201)	0.57	0.63	—	—	0.27	0.33	—	—	0.33
1005 (0402)	0.90	1.10	0.30	0.65	0.40	0.60	0.10	0.30	0.60
1608 (0603)	1.45	1.75	0.45	0.97	0.65	0.95	0.20	0.50	0.85
2012 (0805)	1.80	2.20	0.30	1.11	1.05	1.45	0.25	0.75	1.10
3216 (1206)	3.00	3.40	1.50	2.31	1.40	1.80	0.25	0.75	1.35
3225 (1210)	3.00	3.40	1.50	2.31	2.30	2.70	0.25	0.75	1.35
4532 (1812)	4.20	4.80	2.30	3.46	3.00	3.40	0.25	0.95	1.35

SMC Land Pattern Dimensions

Component Identifier (mm) (in)	Z (mm)	G (mm)	X (mm)	Y (mm) Ref	C (mm) Ref	Placement Grid (No. of Grid Elements)
0603 (0201)	0.72	0.26	0.32	0.23	0.49	—
1005 (0402)	2.20	0.40	0.70	0.90	1.40	2 x 6
1608 (0603)	2.80	0.60	1.00	1.10	1.70	4 x 6
2012 (0805)	3.20	0.60	1.50	1.30	1.90	4 x 8
3216 (1206)	4.40	1.20	1.80	1.60	2.80	4 x 10
3225 (1210)	4.40	1.20	2.70	1.60	2.80	6 x 10
4532 (1812)	5.80	2.00	3.40	1.60	3.90	8 x 12

Lead-Free Surface Mount Resistors

Surface Mount Resistors (SMR) are best suited for commercial industrial and automotive applications. Chip Resistors are suitable for a wide range of solder processes, and are ideal for high-speed electronic assembly equipment. Chip Resistor body size range from 01005 to 1210. Seven-inch reels are standard, but eleven and thirteen-inch reels are available

upon special request. Paper carrier tape is standard for Chip Resistors. In addition, Zero-Ohm Chip Resistors have a copper wire internally. This creates a short condition. Zero-Ohm Chip Resistors can be used to check for continuity after soldering.

SMR Surface Mount Resistors—Lead-Free

Part Description	Body Size (inch)	Body Size (mm)	Metric	Tape Width	Tape Pitch	Quantity Per Reel
01005SMR-PA-Sn	.01"x.005"	0.4x0.2mm	0402	8mm	2mm	20,000
0201SMR-PA-Sn	.02"x.01"	0.6x0.3mm	0603	8mm	2mm	15,000
0402SMR-PA-Sn	.04"x.02"	1.0x0.5mm	1005	8mm	2mm	10,000
0603SMR-PA-Sn	.06"x.03"	1.6x0.8mm	1608	8mm	4mm	5,000
0805SMR-PA-Sn	.08"x.05"	2.0x1.27mm	2012	8mm	4mm	5,000
1206SMR-PA-Sn	.12"x.06"	3.2x1.6mm	3216	8mm	4mm	5,000
1210SMR-PA-Sn	.12"x.10"	3.2x2.6mm	3225	8mm	4mm	4,000

Notes

- Surface mount resistors come packaged on paper carrier tape and 7" reels (larger quantities are available upon request).
- Plastic carrier tape is non-standard for surface mount resistors.
- The numeric section of the part number refers to the physical body size (in inches) of the component. For example: Part number 0402SMR-PA has a body size of .04" length by .02" width.
- Chip resistor arrays are available (call for availability).
- Resistors are now only available standard lead-free with 100% Sn over Ni.

Part Description System

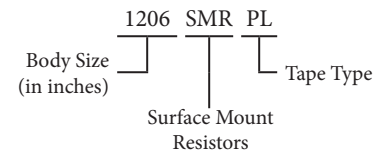

- Tape Type: "PA" = Paper Tape, "PL" = Plastic Tape.

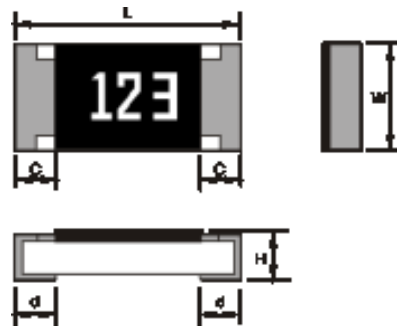

SMR Component Dimensions

Metric	Inch	L	W	H	c	d	* Unit weight/pc.
0402	01005	0.4 +/- 0.02	0.2 +/- 0.02	0.12 +/- 0.02	0.1 +/- 0.03	0.1 +/- 0.03	—
0603	0201	0.6 +/- 0.03	0.3 +/- 0.03	0.23 +/- 0.03	0.1 +/- 0.05	0.15 +/- 0.05	0.16mg
1005	0402	1.0 +/- 0.05	0.5 +/- 0.05	0.35 +/- .05	0.2 +/- 0.1	0.25 +/- 0.05 - 0.10	0.6mg
1608	0603	1.6 +/- 0.1	0.8 +/- 0.15 - 0.05	0.45 +/- 0.10	0.3 +/- 0.1	0.3 +/- 0.1	2mg
2012	0805	2.0 +/- 0.1	1.25 +/- 0.10	0.55 +/- 0.10	0.4 +/- 0.2	0.4 +/- 0.2	5mg
3216	1206	3.2 +/- 0.15	1.6 +/- 0.15	0.55 +/- 0.10	0.5 +/- 0.25	0.5 +/- 0.25	9mg
3225	1210	3.2 +/- 0.15	2.5 +/- 0.15	0.55 +/- 0.15	0.5 +/- 0.25	0.5 +/- 0.25	16mg

Unit: mm *Values for reference



For kits see pages 97, 100, 103, 107, 111, 112, 117, 118, 119, 122, 123, 124.

MELF Resistors

Metal Electrode Leadless Face

Metal Electrode Leadless Face (MELF) Resistors are round or cylindrical in shape. They are available in embossed plastic tape on 7" reels. The terminals on MELF resistors are force-fitted steel caps with Sn plated termination. Parts are also available in Zero-Ohm value. Land pattern sizes for MELF resistors are the same as SMD chip resistor.

MELF Metal Electrode Leadless Face Component Resistors

Part Description	Body Size (inch)	Body Size (mm)	Tape Width	Tape Pitch	Quantity Per Reel
0805SMR-MELF-PL-Sn	.08"x.05"	2.0x1.27mm	8mm	4mm	3,000
1206SMR-MELF-PL-Sn	.12"x.06"	3.0x1.5mm	8mm	4mm	2,000
1406SMR-MELF-PL-Sn	.14"x.06"	3.56x1.5mm	8mm	4mm	3,000
2309SMR-MELF-PL-Sn	.23"x.09"	5.84x2.29mm	12mm	4mm	1,500

Notes

- MELF is the acronym for Metal Electrode Leadless Face.
- 90/10 solder plated end caps.
- Suitable for reflow and wave soldering.
- Meets or exceeds EIAJ-8009, EIA-PDP-100.
- Tape type is plastic.

Part Description System

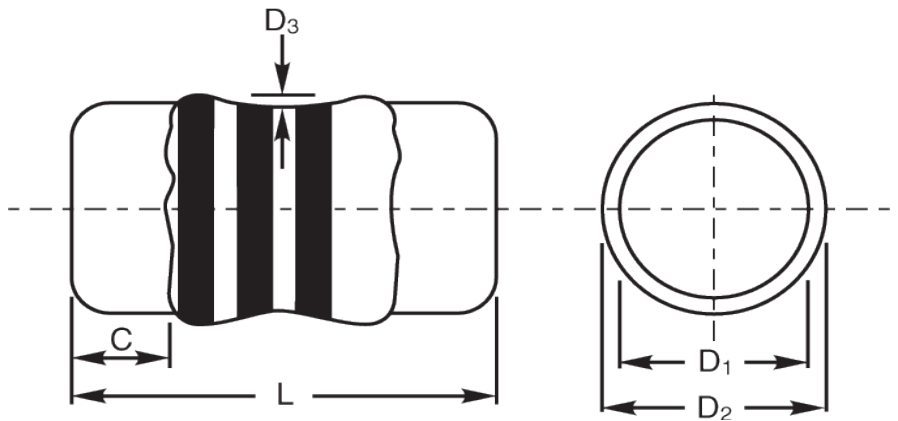
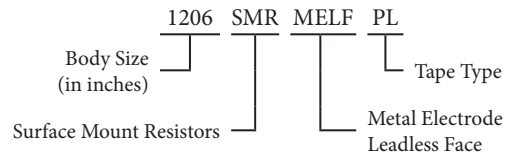

Size Code Dimensions

Case Size	L	C Min	D ₁	D ₂ Max	D ₃ Max
0805	2.0±0.1 (0.079±0.004)	0.3 (0.012)	1.25±0.05 (0.049±0.002)	1.35 (0.053)	0.07 (0.003)
1406	3.5±0.2 (0.138±0.008)	0.5 (0.02)	1.45±0.10 (0.057±0.004)	1.55 (0.061)	0.10 (0.004)
1206	3.2±0.2 (0.126±0.008)		1.55±0.15 (0.061±0.006)	1.75 (0.069)	0.10 (0.004)
2309	5.9±0.2 (0.232±0.008)		2.2±0.10 (0.087±0.004)	2.40 (0.094)	0.15 (0.006)

Unit: mm (Inch)

Lead-Free Surface Mount Tantalum Capacitors

Surface Mount Molded Tantalum Capacitors (SMTA) are polarized capacitors with solderable terminations. Surface Mount Tantalum packages are identified by case size i.e.: A, B, C and D. These case sizes stand for metric footprints of length and width. For example:

A = 3.2 x 1.6mm; B = 3.5 x 2.8mm; C = 6.0 x 3.2mm; D = 7.3 x 4.3mm.

SMTA Surface Mount Tantalum Capacitors

Part Description	Body Size	Case Size	Tape Width	Tape Pitch	Quantity Per Reel
1608SMTA-PL-Sn	1.6x.85mm	R (smaller than A Case)	8mm	4mm	500
3216SMTA-PL-Sn	3.2x1.6mm	A	8mm	4mm	2,000
3528SMTA-PL-Sn	3.5x2.8mm	B	8mm	4mm	2,000
6032SMTA-PL-Sn	6.0x3.2mm	C	12mm	8mm	500/750
7343SMTA-PL-Sn	7.3x4.3mm	D	12mm	8mm	500/750

Notes

- Components are molded, surface mount tantalums.
- Conformal coated tantalums are available.
- Please call for availability of mil-spec surface mount tantalums.
- Standard reel size is 7" (larger sizes are available upon request).
- All tantalum capacitors are on plastic carrier tape.
- Tantalums are now available as standard lead-free with 100% Sn finish.
- SnPb is available upon request based on availability.

Part Description System

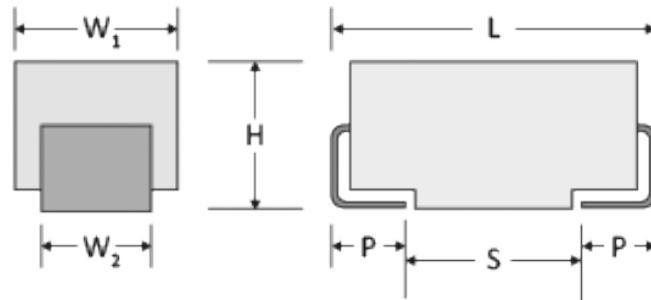
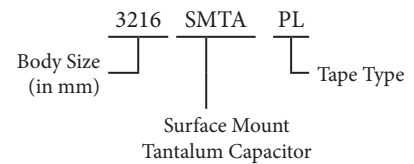

Case Size	Case Size	L ±0.2(±0.008)	W1 ±0.2(±0.008)	H ±0.2(±0.008)	W2 ±0.1(±0.004)	P ±0.3(±0.012)	S Min.
A	3216-18	3.2 (.126)	1.6 (.063)	1.6 (.063)	1.2 (.047)	0.8 (.031)	1.10 (0.043)
B	3528-21	3.5 (.138)	2.8 (.110)	1.9 (.075)	2.2 (.087)	.08 (.031)	1.40 (0.055)
C	6032-28	6.0 (.236)	3.2 (.126)	2.6 (.102)	2.2 (.087)	1.3 (.051)	2.90 (0.114)
D	7343-31	7.3 (.287)	4.3 (.169)	2.9 (.114)	2.4 (.094)	1.3 (.051)	4.40 (0.173)



SOT package is a rectangular surface mount transistor diode with three or more gull-wing leads. The leads are on the two length sides of the package. SOT packages are JEDEC compliant. Popular sizes are the SOT23, DPAK, SOT223 and SOT89.

SMT Surface Mount Transistors

Part Description	Number of Pins	Body Size (W)	Body Size (L)	SC Device	Tape Width	Tape Pitch	Quantity Per Reel
SC90-TR-Sn	3	1.6mm	1.6mm	SC-75A	8mm	4mm	3,000
SOT323-TR-Sn	3	2.0mm	2.1mm	SC-70	8mm	4mm	3,000
SOT353-TR-Sn	5	2.0mm	2.1mm	SC-88A / SOT325	8mm	4mm	3,000
SOT363-TR-Sn	6	2.0mm	2.1mm	SC-88 / SOT326	8mm	4mm	3,000
SOT23-TR-Sn	3	2.9mm	2.4mm	TO-236AB	8mm	4mm	3,000
SOT25-TR-Sn	5	2.9mm	2.8mm	SC-74A	8mm	4mm	3,000
SOT26-TR-Sn	6	2.9mm	2.8mm	SC-74	8mm	4mm	3,000
SOT143-TR-Sn	4	2.9mm	2.5mm	TO-253AA	8mm	4mm	3,000
SOT89-TR-Sn	3	4.5mm	4.0mm	SC-62 / TO-243AA	12mm	8mm	1,000
SOT223-TR-Sn	3	6.5mm	7.0mm	SC-73 / TO-261AA	12mm	8mm	1,000
DPAK-TR-Sn		6.5mm	9.5mm	AC-63 / TO-252-AA	16mm	8mm	2,500
D2PAK-TR-Sn		10.0mm	15.0mm	TO-263AB	24mm	12mm	800/1,000

Notes

- Carrier pack is plastic for surface mount transistors.
- Tape type is plastic.
- Parts only available on Tape and Reel.
- Tin-Lead solder plating available upon request based on availability.
- Lead-free available with 100% Sn alloy.

Part Description System

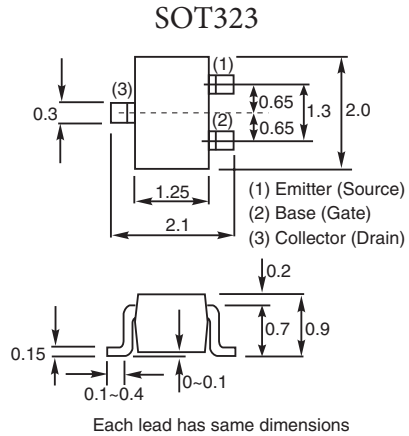
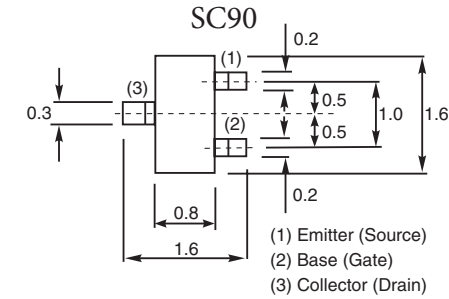
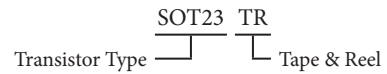

SOT353

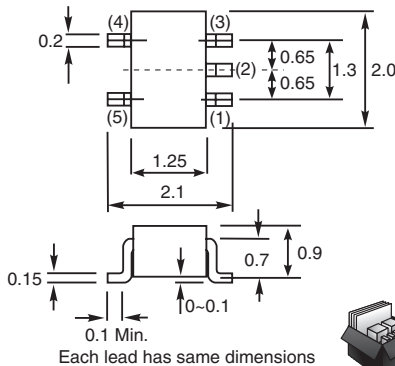

SOT363

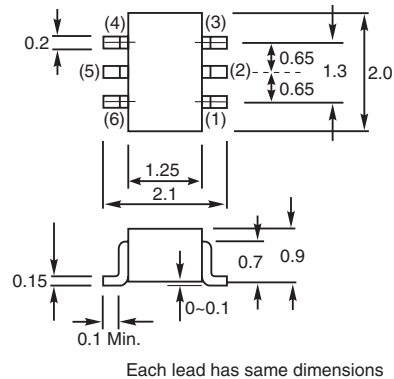

For kits see pages 97, 107, 111, 112, 117, 118, 119.



Lead-Free Surface Mount Transistors

SOT23

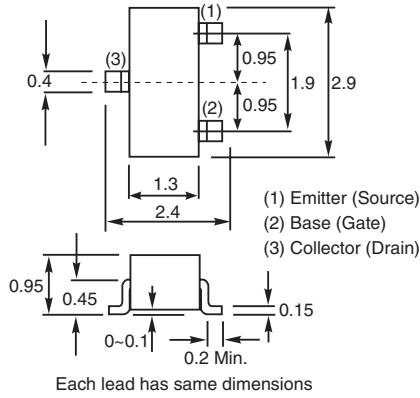

SOT25

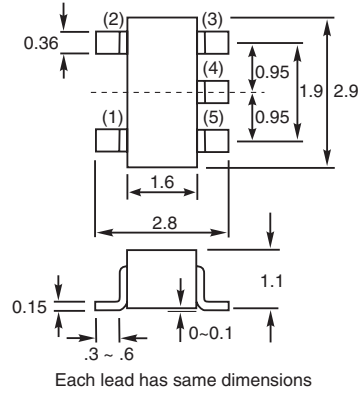

SOT26

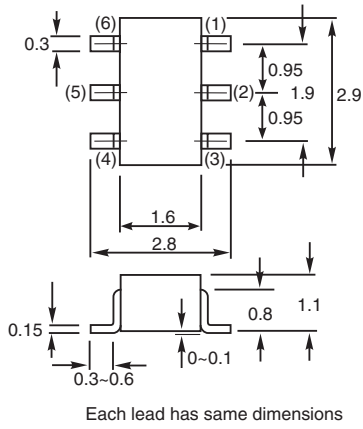

SOT143

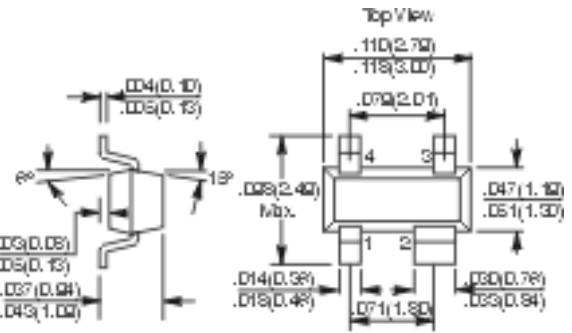

SOT89

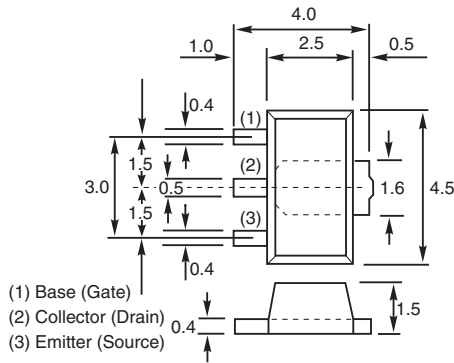

SOT223

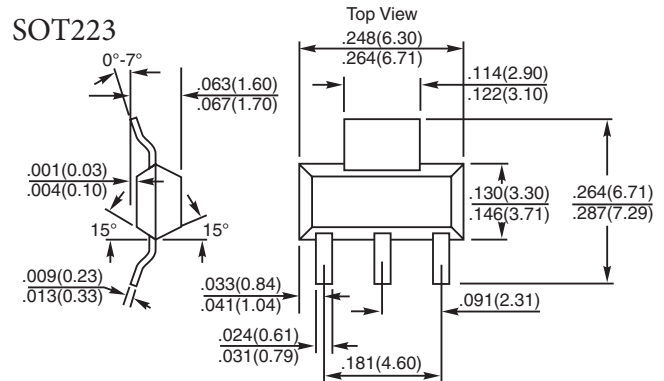

DPAK TO-252

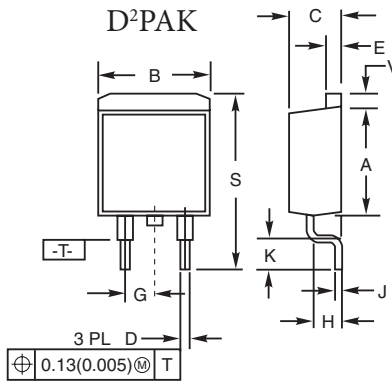
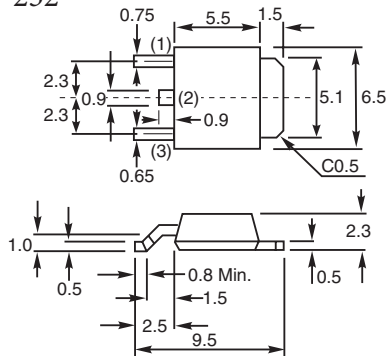

Dim.	Inches		Millimeters	
	Min.	Max.	Min.	Max.
A	0.340	0.380	8.64	9.65
B	0.380	0.405	9.65	10.29
C	0.160	0.190	4.06	4.83
D	0.020	0.035	0.51	0.89
E	0.045	0.055	1.14	1.40
G	0.100 BSC		2.54 BSC	
H	0.080	0.110	2.03	2.79
J	0.018	0.025	0.46	0.64
K	0.090	0.110	2.29	2.79
S	0.575	0.625	14.60	15.88
V	0.045	0.055	1.14	1.40

Notes

- (1) Dimensioning and tolerancing per ANSI Y14.5M, 1982.
- (2) Controlling Dimension: inch.

Surface Mount Electrolytic (SME) capacitors are measured according to the diameter of the can mounted on top of the terminations. Sizes range from 3mm to 24mm in diameter. The most popular sizes are listed below.

Please call if different sizes are needed. These components come packaged on plastic embossed carrier tape. Standard reel sizes are 15".

SME Surface Mount Electrolytic Capacitors

Part Description	Body Size	Tape Width	Tape Pitch	Quantity Per Reel
3mm-SME-PL-Sn	3mm	12mm	8mm	2,000
4mm-SME-PL-Sn	4mm	12mm	8mm	2,000
5mm-SME-PL-Sn	5mm	12mm	12mm	1,000
6.3mm-SME-PL-Sn	6.3mm	16mm	12mm	1,000
8mm-SME-PL-Sn	8mm	16mm	12mm	1,000
10mm-SME-PL-Sn	10mm	24mm	16mm	500
18mm-SME-PL-Sn	18mm	44mm	32mm	125

Notes

- Surface mount electrolytic capacitors come standard on 15" reels.
- Components are measured by the diameter of the electrolytic can.
- Lead-free available with 100% Sn.

Part Description System



øD	L	A	B	C	W	P
4	5.3±0.2	4.3	4.3	2.0	0.5±0.8	1.0
5	5.3±0.2	5.3	5.3	2.3	0.5±0.8	1.5
6.3	5.3±0.2	6.6	6.6	2.7	0.5±0.8	2.0
8	6.3±0.3	8.4	8.4	3.4	0.5±0.8	2.3
8	10±0.5	8.4	8.4	3.0	0.7±1.1	3.1
10	10±0.5	10.4	10.4	3.3	0.7±1.1	4.7
18	16.5	19.0	21.0	6.5	1.2±0.3	6.7

Unit: mm

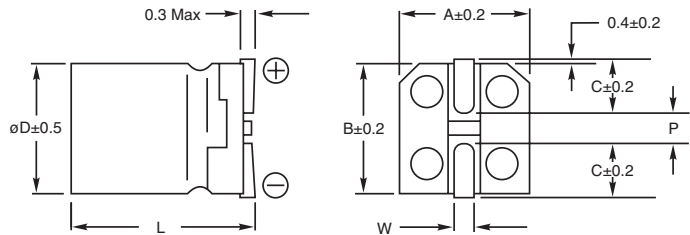

MELF Diodes

Metal Electrode Face Components

Metal Electrode Face Components (MELF) have metallized terminals at each end of a cylindrical body. MELF components are designed to fit the same footprints as flat components i.e., 0805 (.08" x .05") and the 0603 (.06" x .03"). MELF packages are available on plastic tape and reel.

MELF Metal Electrode Face Component Diodes

Part Description	Also Known As	Body Size (mm)	Tape Width	Tape Pitch	Quantity Per Reel
SOD80-TR-Sn	LL-34 or DO-213AA	1.4x3.4mm	8mm	4mm	10,000
SM1-TR-Sn	DO-213AB	2.6x5.0mm	12mm	4mm	5,000

Notes

- MELF Diodes are cylindrical glass or plastic packages with Sn termination for lead-free.

Part Description System

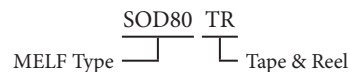

Package	SOD80 (LL34)	SM1 (LL41)
Dimension A	3.4mm	5.0mm
Dimension B	1.5mm	2.8mm

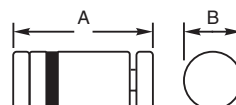

TO type components are through-hole transistors. These are basic electronic components developed in the last forty years. There are many additional types of TO components not listed. TO components come

packaged in tubes, bulk, and tape and reel. Not all components types are available in all packaging styles. Please call for availability. Parts are available lead-free with Sn finish.

Through-Hole Transistors

Part Description	Number of Pins	Case Material	Part Description	Number of Pins	Case Material
TO5-3-B	3	Metal	TO92-3-B	3	Plastic
TO18-3-B	3	Metal	TO220-3-B	3	Plastic

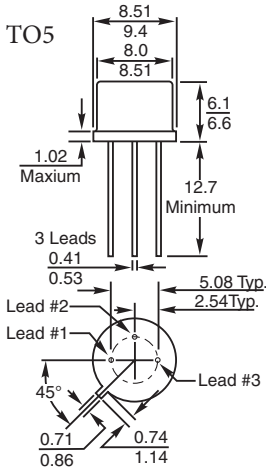

Lead Codes	Pin
1	2 3
SCR C	G A
Transistor E	B C
TRIAC MT1	G MT2

Dimensions: mm

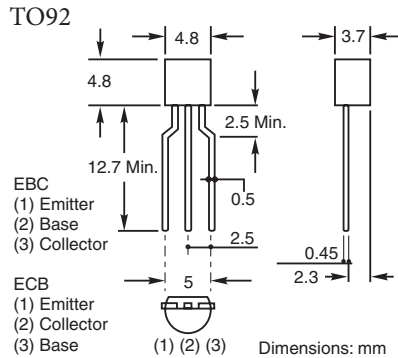

For kits see pages 112, 116, 118, 119, 124.

Part Description System

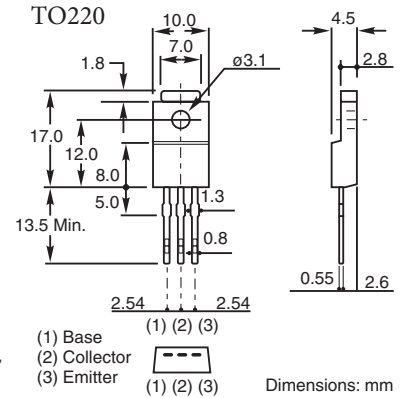
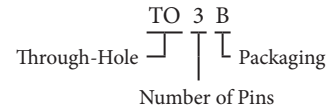

Axial Leaded Resistors

Axial Leaded Resistors are through-hole mounted components.

Axial Leaded Resistors

Part Description	Type	Dimensions L (mm)	Dimensions C (mm)	Dimensions D (mm)	Dimensions l (mm)	Dimensions d (mm)
1/8W-AR-1.6x3.7mm	CF 1/8	3.00 ± 0.1	3.5 Max	1.70 ± 0.2	28.0 ± 3.0	0.45 ± 0.05
1/4W-AR-2.3x6.5mm	CF 1/4	6.35 ± 0.5	7.1 Max	2.30 ± 0.3	28.0 ± 3.0	0.60 ± 0.05
1/2W-AR-3.5x9.5mm	CF 1/2	8.51 ± 0.5	9.52 Max	3.00 ± 0.3	28.0 ± 3.0	0.60 ± 0.05

Notes

- Parts are conformal coated resistors—carbon film type.
- Parts are available in bulk, tape and reel or ammo pack.
- Lead-Free and Zero-Ohm value parts available

Part Description System

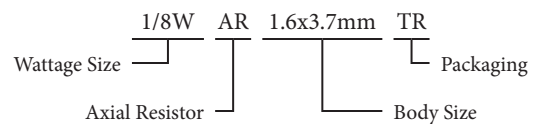

For kits see pages 112, 116, 118, 119, 124.

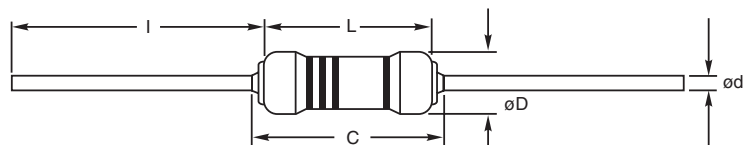

Ceramic Quad Flat Pack

CQFPs are hermetic packages consisting of true pieces of dry pressed ceramic surrounding a uniformed leadframe with tie bar attached. Lead counts for this package range from 14 to 304, with lead pitch ranging from

15.7mil to 50mils. Package leads are gold or Kovar finish and can be solder-coated by special request. Lids are optional for CQFPs, which are sealed over the package cavity at temperatures from 400° to 460° C.

CQFP Ceramic Quad Flat Pack

Part Description	Number of Pins	Body Size (mm)	Body Size (inch)	Pitch
52CQFP-19.0mm-1.27mm	52	19.0mm sq	.750" sq	1.27mm
68CQFP-24.1mm-1.27mm	68	24.1mm sq	.950" sq	1.27mm
84CQFP-16.5mm-.65mm	84	16.5mm sq	.650" sq	.65mm
100CQFP-19.0mm-.65mm	100	19.0mm sq	.750" sq	.65mm
132CQFP-24.1mm-.65mm	132	24.1mm sq	.950" sq	.65mm
172CQFP-29.2mm-.65mm	172	29.2mm sq	1.150" sq	.65mm
196CQFP-32.0mm-.50mm	196	32.0mm sq	1.260" sq	.65mm

Notes

- CQFPs are available with or without combo lid.
- Pins are flat (sandwiched) with tie bar.
- Parts are packaged in non-JEDEC trays.
- Parts available with a daisy-chain configuration upon request.
- Due to the custom nature of the package, body size and dimensions can change without notice.

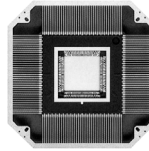

Part Description System

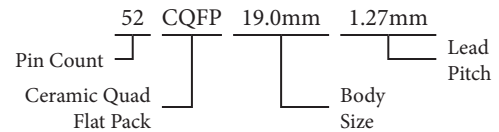

LCC

Leadless Ceramic Carrier

This surface mount package consists of a ceramic base that has metalized castellations/pads on the sides and bottom of the package. LCC packages have pads on all four sides of the package. Lids for LCCs can be either

metal or ceramic. Lids are attached after die attach. This allows for a hermetically sealed environment for the die.

LCC Leadless Ceramic Carrier

Part Description	Number of Castellations	Body Size (mm)	Body Size (inch)	Pitch
16LCC-1.27mm-7.36x8.96mm	16	7.36x8.96mm	.350"x.285"	1.27mm
20LCC-1.27mm-8.90mm	20	8.90mm sq	.350" sq	1.27mm
28LCC-1.27mm-11.5mm	28	11.50mm sq	.450" sq	1.27mm
40LCC-1.0mm-10.1mm	40	10.10mm sq	.400" sq	1.0mm
44LCC-1.27mm-16.5mm	44	16.50mm sq	.650" sq	1.27mm
68LCC-1.27mm-24.11mm	68	24.11mm sq	.950" sq	1.27mm

Notes

- LCCs are available with or without combo lid.
- Gold castellations are standard, but can be solder-tinned with 100% Sn or SnPb alloy.
- Parts are packaged in non-JEDEC trays.
- Parts available with a daisy-chain configuration upon request.
- Due to the custom nature of the package, body size and dimensions can change without notice.

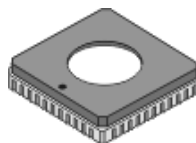

Part Description System

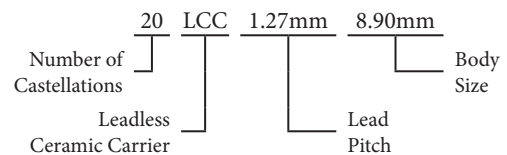

For recommended kit see page 96. 102.



Assembly tools and supplies for Medical Manufacturing,
Bio-Medical Manufacturing & Research,
Electronics Assembly and Aerospace Manufacturing.



Professional-grade workstation benches and chairs



Practical Tools Inc.
USA
10762 Noel St.
Los Alamitos, CA
90720-2548
Phone: 714-252-1192
Fax: 714-252-0026
avilligan@BuyPT.com

www.BuyPT.com



Practical Tools Inc.
Costa Rica
Calle 22, Ave. 3 y 5 #351
San Jose Costa Rica
Office Phone (506) 2223-0371
Office Fax (506) 2258-5234
pmarin@aseprocr.com

Export Codes for Practical Components Products

Item	Code	Description	USA Governing Agency
Harmonized Code	8542.90.0000	Electronics Intergraded Circuits and Microassembly Parts	U.S. Department of Commerce US Census Bureau
ECCN Export Control Classification Number	EAR99	Export administration Regulations (EAR)	U.S. Department of Commerce Bureau of Industry and Security (BIS)
Cage Code	AVZ14	Commercial and Government Entity Code	Defense Logistics Agency (DLA)
ITAR	N/A	Does not apply to Practical Components products	US Department of State Directorate of Defense Trade Controls (DDTC)

When only the physical characteristics of the tape matter, we offer empty carrier tape reels in a variety of widths and pitches. Empty carrier tape reels are plastic embossed or paper carrier tape with sealed cover tape to simulate running parts without the cost and mess during feeder applications. CTReels are a cost saving alternative compared to actual parts on tape.

Empty Carrier Tape Reels

Part Description	Reel Size	Tape Width	Tape Pitch	Standard Pocket	Pockets Per Reel	Tape Type
7"x8mm-CTR-PA	7"	8mm	2mm	0402SMR	10,000	Paper
			4mm	0805SMR	5,000	Paper
7"x8mm-CTR-PL	7"	8mm	2mm	0402SMR	10,000	Plastic
			4mm	0805SMR	5,000	Plastic
7"x12mm-CTR-PL	7"	12mm	8mm	1812SMC	1,000	Paper
7"x16mm-CTR-PL	7"	16mm	12mm	SO16-7.6mm	500	Plastic
13"x8mm-CTR-PA	13"	8mm	4mm	0805SMR	10,000	Paper
13"x8mm-CTR-PL	13"	8mm	4mm	0805SMR	10,000	Plastic
13"x12mm-CTR-PL	13mm	12mm	8mm	SO8-3.8mm	2,500	Plastic
13"x16mm-CTR-PL	13"	16mm	8mm	SO14-3.8mm	2,500	Plastic
			12mm	SO16-7.6mm	1,000	Plastic
			12mm	SO20-7.6mm	1,000	Plastic
13"x24mm-CTR-PL	13"	24mm	16mm	PLCC28	750	Plastic
			20mm	LQFP-12mm	750	Plastic
			24mm	PBGA-13mm	500	Plastic
			12mm	T1-TSOP32	1,000	Plastic
13"x32mm-CTR-PL	13"	32mm	16mm	T1-TSOP32	1,000	Plastic
			24mm	PLCC44	750	Plastic
			16mm	T11-TSOP54	500	Plastic
			20mm	TBA	1,000	Plastic
13"x44mm-CTR-PL	13"	44mm	24mm	LQFP-20mm	750	Plastic
			32mm	PBGA-23mm	250	Plastic
			36mm	TBA	250	Plastic
			40mm	TBA	200	Plastic
			40mm	PBGA-35mm	250	Plastic
13"x56mm-CTR-PL	13"	56mm	44mm	QFP-32mm	250	Plastic
			44mm	QFP-32mm	250	Plastic
13"x72mm-CTR-PL	13"	72mm	24mm	TBA	300	Plastic

Notes

- Taped to EIA 481 standards.
- Plastic (PL) carrier tape is standard. Paper (PA) carrier tape is special order.
- Reels come standard with Heat Seal Cover Tape.
- PSA available upon request (pressure sensitive adhesive).
- 10–100g peel back pressure for 8mm carrier tapes.
- 10–130g peel back pressure for 12–56mm carrier tapes.
- 10–150g peel back pressure for 72mm carrier tapes.
- Additional pocket types available upon request.
- Additional widths and pitches may be available, call for details.

Part Description System

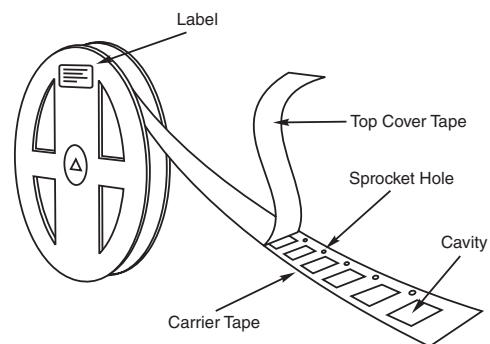
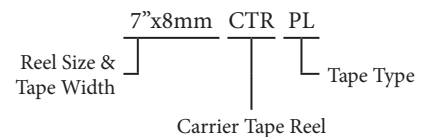

Tape and Reel Specifications

Part Description	Tape Width	Tape Pitch	Reel Size	Qty Per Reel
01005SMR-PA	8mm	2mm	7"	20,000
0201SMR-PA	8mm	2mm	7"	15,000
0402SMR-PA	8mm	2mm	7"	10,000
0603SMR-PA	8mm	4mm	7"	5,000
0805SMR-PA	8mm	4mm	7"	5,000
1206SMR-PA	8mm	4mm	7"	5,000
1210SMR-PA	8mm	4mm	7"	5,000
0201SMC-PA	8mm	2mm	7"	15,000
0402SMC-PA	8mm	2mm	7"	10,000
0603SMC-PA	8mm	4mm	7"	4,000
0805SMC-PA	8mm	4mm	7"	4,000
1206SMC-PA	8mm	4mm	7"	4,000
0805SMC-PL	8mm	4mm	7"	4,000
1206SMC-PL	8mm	4mm	7"	3,000
1210SMC-PL	8mm	4mm	7"	3,000
1812SMC-PL	12mm	8mm	7"	1,000
1825SMC-PL	12mm	8mm	7"	1,000
3mm-SME-PL	12mm	8mm	13"	2,000
4mm-SME-PL	12mm	8mm	13"	2,000
5mm-SME-PL	12mm	12mm	13"	1,000
6.3mm-SME-PL	16mm	12mm	13"	1,000
8mm-SME-PL	16mm	12mm	13"	1,000
10mm-SME-PL	24mm	16mm	13"	500
18mm-SME-PL	44mm	32mm	13"	125
3216SMTA-PL	8mm	4mm	7"	2,000
3528SMTA-PL	8mm	4mm	7"	2,000
6032SMTA-PL	12mm	8mm	7"	500
7343SMTA-PL	12mm	8mm	7"	500
SC90-TR (supermini)	8mm	4mm	7"	3,000
SOT323-TR	8mm	4mm	7"	3,000
SOT353-TR	8mm	4mm	7"	3,000
SOT363-TR	8mm	4mm	7"	3,000
SOT23-TR	8mm	4mm	7"	3,000
SOT25-TR	8mm	4mm	7"	3,000
SOT26-TR	8mm	4mm	7"	3,000
SOT143-TR	8mm	4mm	7"	3,000
SOT89-TR	12mm	8mm	7"	1,000
SOT223-TR	12mm	8mm	7"	1,000
DPAK-TR	16mm	8mm	13"	2,500
D2PAK-TR	24mm	12mm	13"	800/1,000
SO8GTR-3.8mm	12mm	8mm	13"	2,500
SO14GTR-3.8mm	16mm	8mm	13"	2,500
SO16GTR-3.8mm	16mm	8mm	13"	2,500
SO16GTR-7.6mm	16mm	12mm	13"	1,000
SO20GTR-7.6mm	24mm	12mm	13"	1,000
SO28GTR-7.6mm	24mm	12mm	13"	1,000
SO28JTR-7.6mm	24mm	12mm	13"	1,000
SSOP14TR-5.3mm	16mm	12mm	13"	1,000
SSOP16TR-5.3mm	16mm	12mm	13"	1,000
SSOP20TR-5.3mm	16mm	12mm	13"	1,000
SSOP24TR-5.3mm	16mm	12mm	13"	1,000
SSOP28TR-5.3mm	16/24mm	12mm	13"	1,000
SSOP48TR-7.6mm	32mm	12/16mm	13"	1,000
SSOP56TR-7.6mm	32mm	12/16mm	13"	500

Part Description	Tape Width	Tape Pitch	Reel Size	Qty Per Reel
TSSOP8TR-3.0mm	12mm	8mm	13"	2,500
TSSOP8TR-4.4mm	12/16mm	8mm	13"	1,000/2,500
TSSOP10TR-3.0mm	12mm	8mm	13"	2,500
TSSOP14TR-4.4mm	12/16mm	8mm	13"	1,000/2,500
TSSOP16TR-4.4mm	12/16mm	8mm	13"	1,000/2,500
TSSOP20TR-4.4mm	16mm	8/12mm	13"	1,000/2,500
TSSOP24TR-4.4mm	16mm	8/12mm	13"	1,000/2,500
TSSOP28TR-4.4mm	16mm	8/12mm	13"	1,000
TSSOP32TR-6.1mm	24mm	12mm	13"	1,000
TSSOP44TR-4.4mm	24mm	12mm	13"	1,000
TSSOP48TR-6.1mm	24mm	12mm	13"	1,000
TSSOP56TR-4.4mm	24mm	12mm	13"	1,000
TSSOP56TR-6.1mm	24mm	12mm	13"	1,000
T1-TSOP28-8.1x11.8mm-.55mm	24mm	12mm	13"	1,000
T1-TSOP32-8x18.4mm-.5mm	32mm	12/16mm	13"	1,000
T1-TSOP48-12x18.4mm-.5mm	32mm	16mm	13"	1,000
T11-TSOP32-10.16x20.95mm-1.27mm	32mm	16mm	13"	1,000
T11-TSOP54-10.16x22.22mm-.8mm	44mm	16mm	13"	1,000
PLCC20TR	16mm	12mm	13"	1,000
PLCC28TR	24mm	16mm	13"	750
PLCC32TR	24mm	16mm	13"	750
PLCC44TR	32mm	24mm	13"	450
PLCC68TR	44mm	32mm	13"	230/250
PLCC84TR	44mm	36mm	13"	250
QFP-10mm sq.	24mm	24mm	13"	500
QFP-14mm sq.	32mm	24mm	13"	350
QFP-14x20mm	44mm	32mm	13"	500
QFP-28mm sq.	44mm	40mm	13"	200
QFP-32mm sq.	56mm	44mm	13"	200
LQFP/TQFP- 5mm sq.	16mm	12mm	13"	1,000
LQFP/TQFP- 7mm sq.	16mm	12mm	13"	1,000
LQFP/TQFP- 10mm sq.	24mm	16/24mm	13"	1,000
LQFP/TQFP- 12mm sq.	24mm	20/24mm	13"	1,000
LQFP/TQFP- 14mm sq.	32mm	24mm	13"	750
LQFP/TQFP- 14x20mm	44mm	32mm	13"	500
LQFP/TQFP- 20mm sq.	44mm	24mm	13"	500
LQFP/TQFP- 24mm sq.	44mm	32mm	13"	500
PBGA-13mm sq.	24mm	24mm	13"	500
PBGA-15mm sq.	24mm	24mm	13"	500
PBGA-17mm sq.	24mm	24mm	13"	500
PBGA-23mm sq.	44mm	32mm	13"	250
PBGA-27mm sq.	44mm	32mm	13"	250
PBGA-35mm sq.	56mm	40mm	13"	250
CTBGA/CABGA-5mm sq.	12mm	8mm	13"	1,000
CTBGA/CABGA-6mm sq.	16mm	8mm	13"	1,000
CTBGA/CABGA-7mm sq.	16mm	12mm	13"	1,000
CTBGA/CABGA-8mm sq.	16mm	12mm	13"	1,000
CTBGA/CABGA-9mm sq.	16mm	12mm	13"	1,000
CTBGA/CABGA-10mm sq.	24mm	12mm	13"	1,000
CTBGA/CABGA-11mm sq.	24mm	16mm	13"	1,000
CTBGA/CABGA-12mm sq.	24mm	16mm	13"	1,000
CTBGA/CABGA-14mm sq.	24mm	24mm	13"	500
CTBGA/CABGA-17mm sq.	24mm	24mm	13"	500

Advanced Wafer Packages

TEG Wafers and Test Elements

Practical Components is the exclusive distributor of Walts Co., LTD in the U.S.A. Walts provides next generation assembly technology for semiconductors with leading-edge technologies. As the de facto standard, Walts products are used in research and development sites worldwide.

Their well experienced designers can also custom-make TEG (test Element Groups) to better suit your needs. A wide variety of fil, sputtering and deposition, back grinding, dicing, bump forming, assembling and analysis are available.

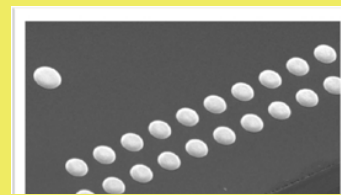
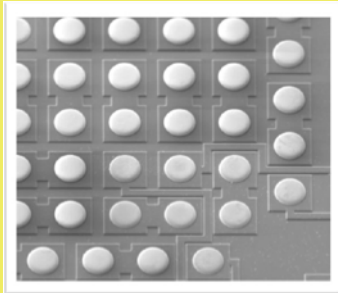
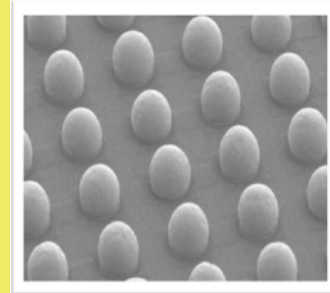
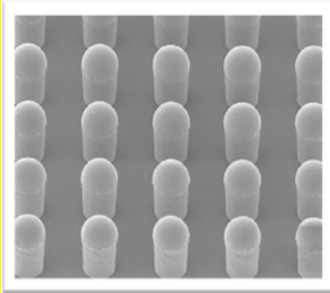









TSV









Wafer Size:	ϕ 4inch ~ ϕ 12inch
Wafer Thickness:	min. 10 μ m
Bump Materials:	Solder Bump (Lead Free) Gold Bump (Plate, Stud) Copper Bump (Plate, Pillar, Stud)
Minimum Pitch:	Full Area: min. 20 μ m Peripheral: min. 20 μ m
Deposition:	SiN, PBO, Polyimide, Back Side Metallization etc.

Advanced Wafer Package Line Up (1)

● Top Side ■ Bottom Side

Material Product	AU		Solder		Cu			Ni		Electroless Ni/Au
	Plate 	STUD 	Plate 	Mount 	Plate 	Plate 	Plate 	Plate 	Plate 	
MB50	—	●	—	—	●	●	●	●	●	●
MB80	—	●	—	—	●	●	●	●	●	●
A58R	—	—	—	—	●	—	—	—	—	●
MB150A/ MB150B	—	●	—	—	●	●	●	●	●	●
MB6020	—	●	—	—	—	—	—	—	—	●
CC40	—	—	—	—	●	●	●	●	●	●
IP40	—	—	—	—	●	●	●	●	●	●
IP40A	—	—	—	—	●	●	—	—	—	●
CC80	—	●	—	—	●	●	●	●	●	●
IP80	—	—	—	—	●	●	●	●	●	●
CC80TSV	—	—	—	—	—	●	—	—	—	■
IP80MarkIV	—	—	—	—	●	●	—	—	—	●
IP80MarkIV	—	—	—	—	—	—	—	—	—	●

Advanced Wafer Package Line Up (2)

Material Product	Au		Solder		Cu			Ni		Electroless Ni/Au
	PLATE 	STUD 	PLATE 	MOUNT 	PLATE 	PLATE 	PLATE 	PLATE 	PLATE 	
WM40-0101	—	—	—	—	■	●	—	—	—	●
WM40-0102	—	—	—	—	—	●	—	—	—	●
WM40-0103	—	—	—	—	—	●	—	—	—	●
IPWM40	—	—	—	—	—	—	—	—	—	●
HBM-T	—	—	—	—	●	●	—	—	—	●
IPHBM	—	—	—	—	—	—	—	—	—	●
FC150LC	—	—	—	—	●	●	—	—	—	●
FC120	—	—	—	—	●	●	●	●	●	●
FC150/FC150SC	—	—	—	●	●	●	●	●	●	●
FC200/FC200SC	—	—	—	●	●	●	●	●	●	●
FBW	—	—	—	—	●	●	—	—	—	—
WLP	—	—	—	●	—	—	—	—	—	—
Free Size Cut	—	—	—	●	—	—	—	—	—	—
ME	—	—	—	—	●	—	—	—	—	—
STAC	—	●	—	—	●	●	●	●	●	●
STAC150FA/ 300FA	—	—	—	—	●	●	●	●	●	—

Advanced Wafer Package Line Up (3)

● Top Side ■ Bottom Side

Material Product	Au		Solder		Cu			Ni		Electroless Ni/Au
	PLATE	STUD	PLATE	MOUNT	PLATE	PLATE	PLATE	PLATE	PLATE	
HPW	—	●	—	—	●	●	●	●	●	●
HPW150FA/ 300FA	—	—	—	—	●	●	●	●	●	—
HPW Mark II	—	—	—	—	●	●	●	—	—	●
LCD30A	●	—	—	—	—	—	—	—	—	—
PWB8	—	—	—	—	—	—	—	—	—	●
SI0631	—	—	—	—	—	—	—	—	—	—
ITO1101/ 1102	—	—	—	—	—	—	—	—	—	—

Advanced Wafer KIT Line UP

Material Product	Ni/Au	Cu	Cu +OSP	E-679FG SAC	E-700G SAC	E-705G SAC	E-700G NiPdAu + SAC	E-705G NiPdAu + SAC	NiPdAu
CC80	—	●	●	—	—	—	—	—	—
FC150LC-1 × 1	—	—	—	—	—	—	—	●	—
FC120-1 × 1	—	●	●	—	—	●	—	—	—
FC120-2 × 2	—	●	●	—	—	●	—	—	—
FC150-1 × 1	●	●	●	●	—	—	—	—	—
FC150-2 × 2	—	●	●	—	●	—	●	●	—
FC200-1 × 1	●	●	●	●	—	—	—	—	—
FC200-2 × 2	●	—	—	—	●	—	—	—	—
WLP300P/400P	●	—	—	—	—	—	—	—	—
STAC	—	—	—	—	—	—	—	—	●

Specifications	TYPE-A	TYPE-B
Wafer Size	8 inch	8 inch
Wafer Thickness	725±25µm	725±25µm
Chip Size	7.3mm■	7.3mm■
Pad Pitch	50µm	50µm
Function	Daisy Chain	Daisy Chain
Pad config	Peripheral	Peripheral
Electrode	Au-Stud Bump Wire Bonding	Cu-Pillar Au-Plated Solder Plated Ni on Cu-Pillar
Pad Size	48µm■	48µm■
Bump Size	—	Cu, Au:30µm ●
		Cu:φ25µm●
Bump Height	—	Cu30um+SnAg15um
Passivation Opening	40µm■	φ15µm●
Scribe Width	120µm	120µm
Number of Pad	544 pads/chip	544 pads/chip
Number of Chip	478 chips/wafer	478 chips/wafer

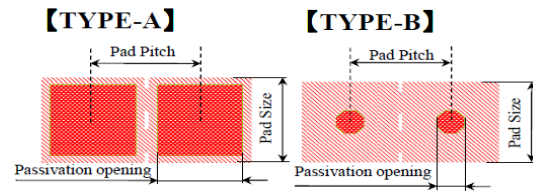
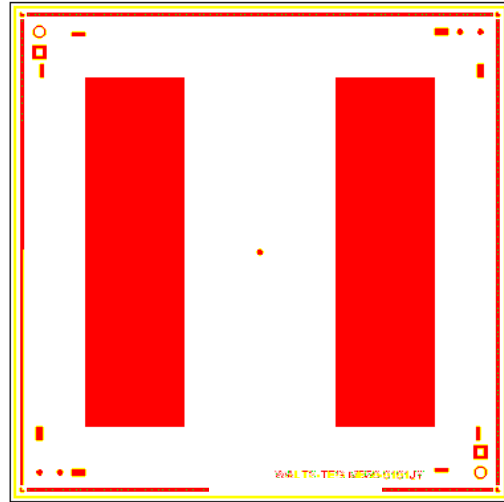

MB80-STG0101JY

Specifications	TYPE-A	TYPE-B
Wafer Size	8 inch	8 inch
Wafer Thickness	725±25µm	725±25µm
Chip Size	7.3mm■	7.3mm■
Pad pitch	80µm staggered	80µm staggered
Function	Daisy Chain	Daisy Chain
Pad config	Peripheral	Peripheral
Electrode	Wire Bonding	Cu pillar
Pad Size	76µm■	76µm■
Bump Size	-	38µm■
Passivation opening	70µm■	70µm■
Scribe width	120µm	120µm
Number of Pad	648 pads/chip	648 pads/chip
Number of Chip	478 chips/wafer	478 chips/wafer

■ Bottom Side

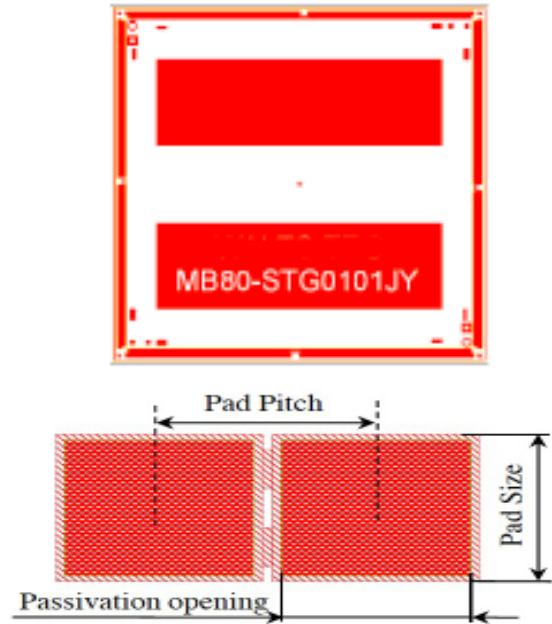

AS8R

Wafer Size	8 inch
Wafer Thickness	725±25µm
Chip Size	3.5mm■
Pad pitch	120µm
Function	Daisy Chain
Pad config	Peripheral
Electrode	Wire Bonding Stud Bump Cu pillar
Pad Size	115µm×125µm
Passivation opening	95µm×100µm
Scribe width	120µm
Number of Pad	96 pads (Outer line) 88 pads (Inner line)
Number of Chip	2266 chips/wafer

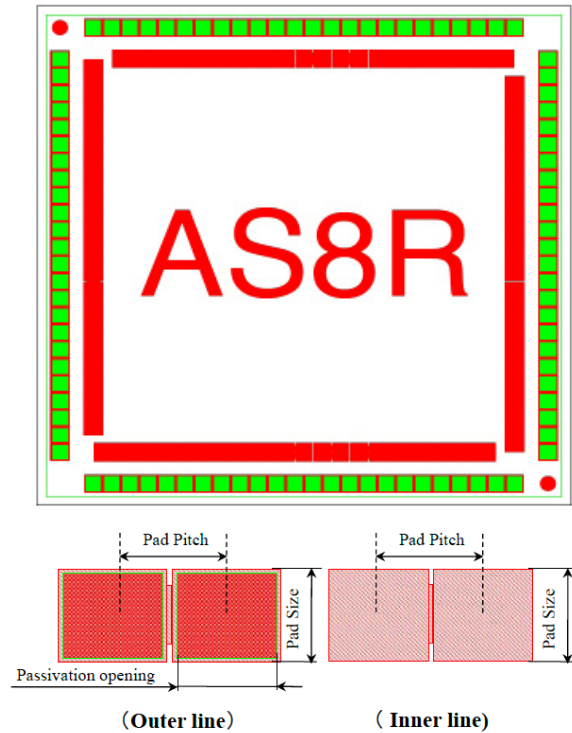

MB130A-STG0101JY MB130B-STG0101JY

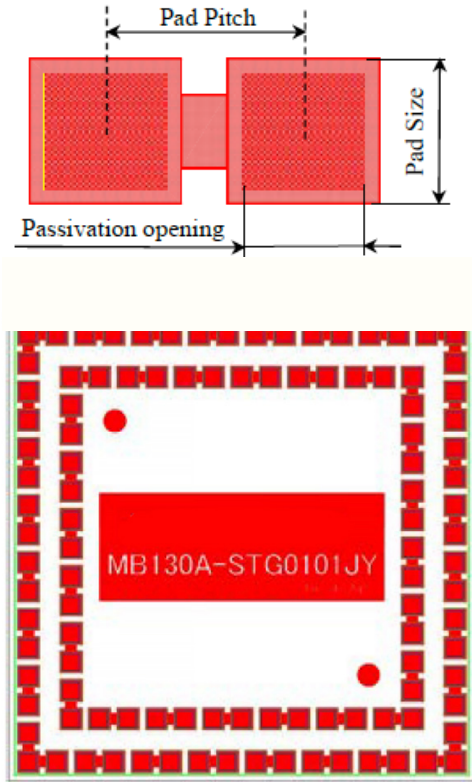

Specifications	MB130A TYPE-A	MB130A TYPE-B	MB130B
Wafer Size	8 inch	8 inch	8 inch
Wafer Thickness	725±25µm	725±25µm	725±25µm
Chip Size	2.13mm■	2.13mm■	2.13mm■
Pad pitch	130µm	130µm	130µm
Metal Thickness	Al-Si-Cu 1µm or 2µm or 3µm	Al-Si-Cu 1µm or 2µm or 3µm	Al-Cu 3µm
Function	Daisy Chain	Daisy Chain	Daisy Chain
Pad config	Peripheral	Peripheral	Peripheral
Electrode	Wire Bonding Au Stud Bump	Cu Bump	Wire Bonding Au Stud Bump
Pad Size	100µm■	100µm■	100µm■
Passivation opening	80µm■	80µm■	80µm■
Polyimide opening	90µm■	90µm■	90µm■
Bump Size	-	Φ70µm	-
Scribe width	60µm	60µm	60µm
Number of Pad	108 pads/chip 15pads×4(Outer line) 12pads×4(Inner line)	108 pads/chip 15pads×4(Outer line) 12pads×4(Inner line)	108 pads/chip 15pads×4(Outer line) 12pads×4(Inner line)
Number of Chip	6060 chips/wafer	6060 chips/wafer	6060 chips/wafer

MB6020-0102JY

Specifications	
Wafer Size	8 inch
Wafer Thickness	725±25um
Chip Size	3.0mm■
Pad Pitch	60/55/50/45/40/35/30/25/20
Metal Thickness	0.6µm or 0.8µm
Function	Daisy Chain
Pad Config	Peripheral
Electrode	Wire Bonding
Pad Size	(57×110µm) (52×110µm) (47×110µm) (42×110µm) (37×110µm) (32×110µm)
Passivation Opening	(53×100µm) (48×100µm) (43×100µm) (38×100µm) (33×100µm) (28×100µm)
Scribe Width	100µm
Number of Pad	(40pads ×4) (40pads ×4) (38pads ×4) (38pads ×4) (36pads ×4) (34pads ×4)
Number of Chip	3016 chips/wafer

■ Bottom Side

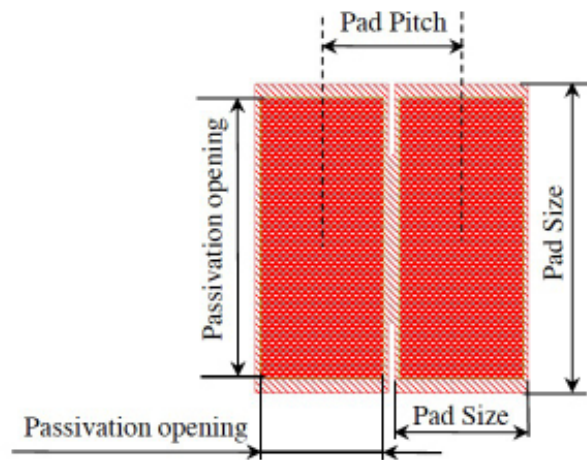
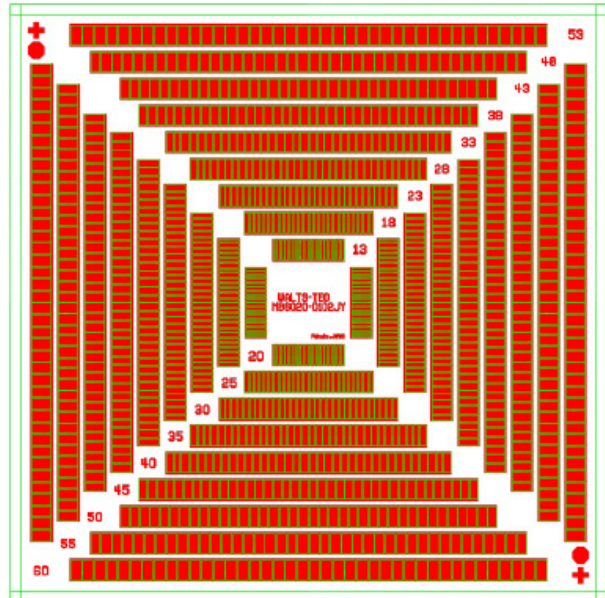

Specifications	
Wafer Size	8 inch
Wafer Thickness	725±25um
Chip Size	7.3mm■
Pad Pitch	40µm pitch Full area + Staggered (Model I) 40µm pitch Staggered (Model II)
Function	Daisy Chain
Pad Config	Full Area (Model I) Peripheral (Model II)
Electrode/Height	Cu10um+SnAg10um
Pad Size	32µm ■
Passivation Opening	7µm ●
Scribe Width	120µm
Number of Chip	478 chips/wafer
	● Top Side ■ Bottom Side

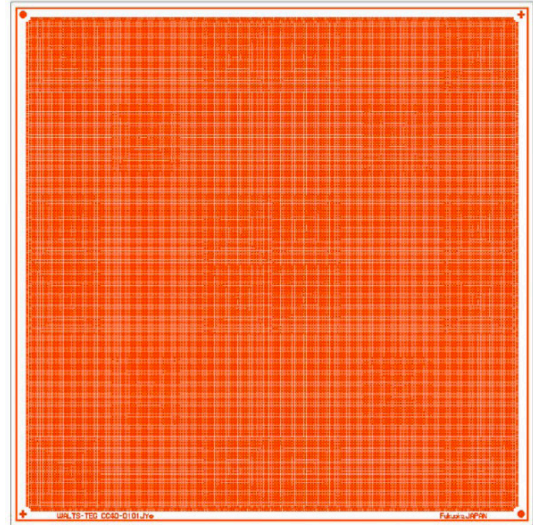

Bump Layout	Bump Size	Number of Bumps
Model I	φ22um	29576
Model II	φ22um	1352

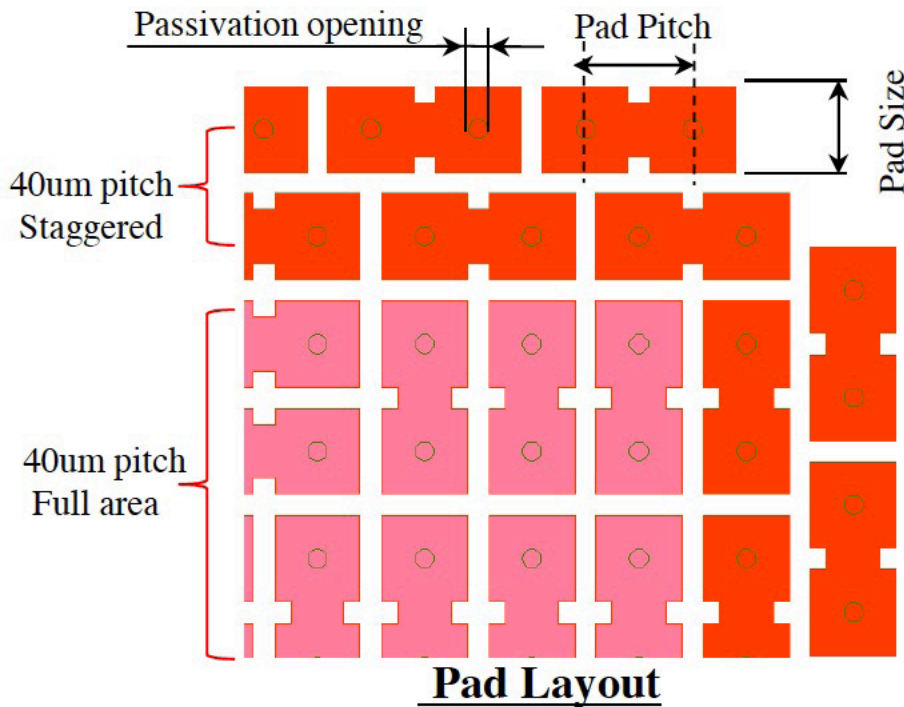

【Bump Layout】

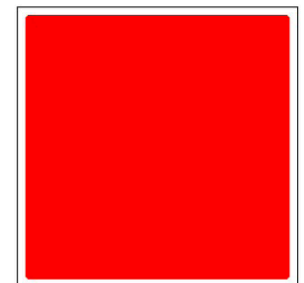

STANDARD (Model I)

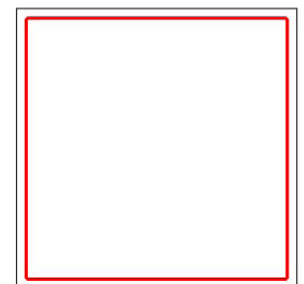

STANDARD (Model II)

Applications
Hybrid bonding evaluation

IP40-0101JY

IP40A-0101JY

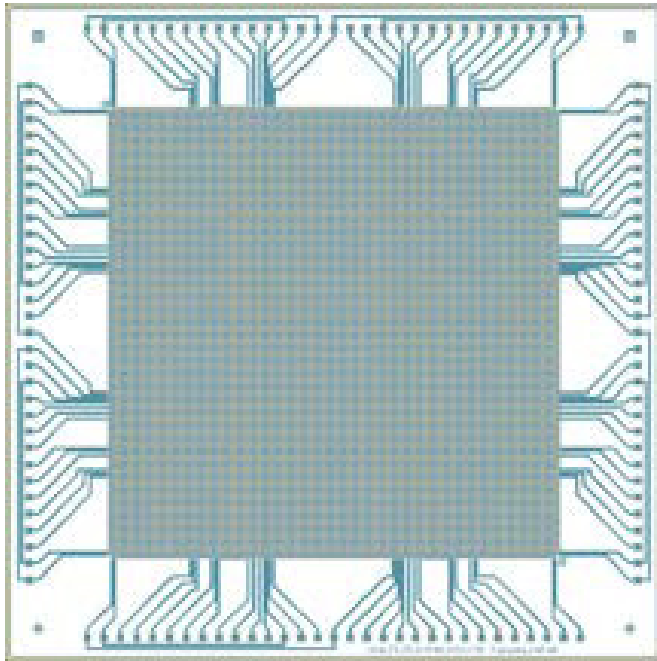

Silicon Interposer {for CC40-0101JY}

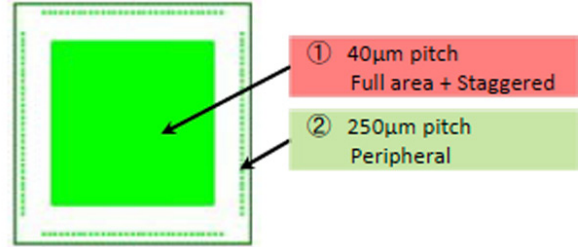

STANDARD (Model I)

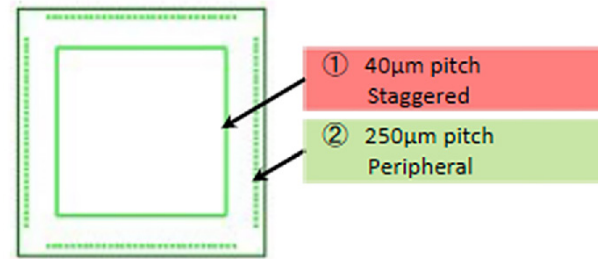

STANDARD (Model II)

Specifications	IP40(Model 1)	IP40A(Model I)	IP40(Model II)
Wafer Size	8 inch	12 inch	8 inch
Wafer Thickness	725±25um	775±25um	725±25um
Chip Size	10.0mm	10.0mm	10.0mm
Pad Pitch	① 40µm pitch Full Area + Staggered ② 250µm pitch Peripheral		① 40µm pitch Staggered ② 250µm pitch Peripheral
Function	Daisy Chain / Bump Short Check / Vernier Breakdown Voltage Check between the Bumps		
Pad Config	Full Area		Peripheral
Pad Size	① 32µm■ ② 110µm■		
Passivation Opening	① 20 µm ② 100 µm■		
Scribe Width	100µm		
Number of Pad	① 29576 pads ② 124 pads		① 1352 pads ② 124 pads
Number of Chip	256 chips/wafer	616 chips/wafer	256 chips/wafer
Surface Spec of Round	Electroless Ni/Au plating		

Applications
Hybrid bonding evaluation

Concept of CC80 Series

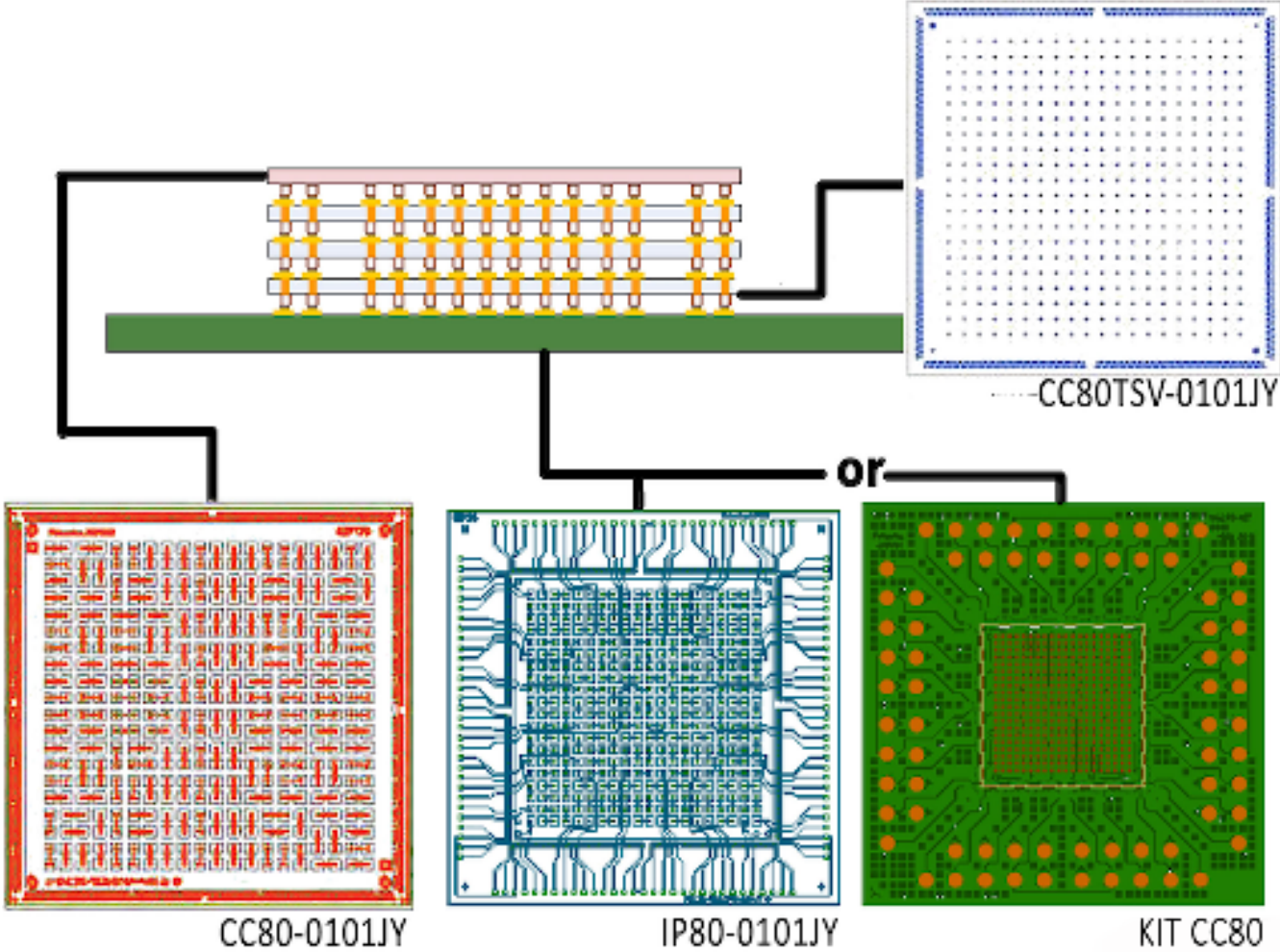

CC80-0101JY

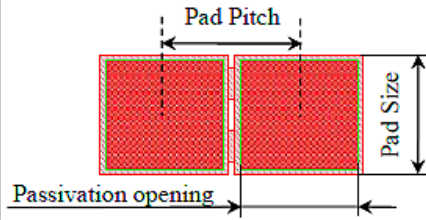
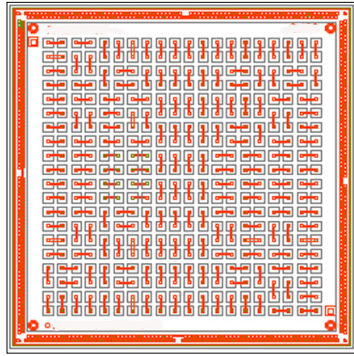

Bump layout

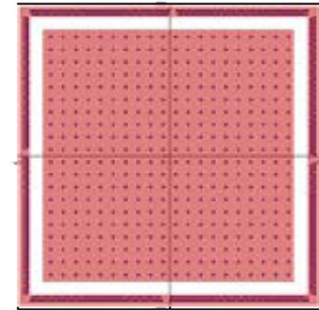

Wafer Size	8 inch
Wafer Thickness	725±25µm
Chip Size	7.3mm■
Pad pitch	80µm staggered (Peripheral) 300µm Full area (Center core)
Function	Daisy Chain
Pad config	Peripheral
Electrode	Au-stud Bump Wire Bonding Au Plating Cu pillar
Pad size	58µm■
Passivation opening	48µm■
Scribe width	120µm
Bump Size	38µm■ or φ42µm●
Bump Height	Cu30um+SnAg15um
Number of Bump	1048 *Peripheral(648) Full Area(400)
Number of Chip	478 chips/wafer

IP80-0101JY Silicon Interposer [for CC80-0101JY]

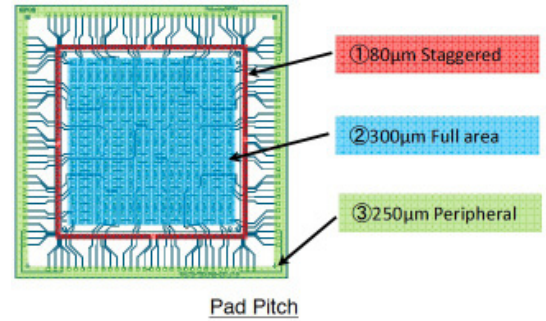
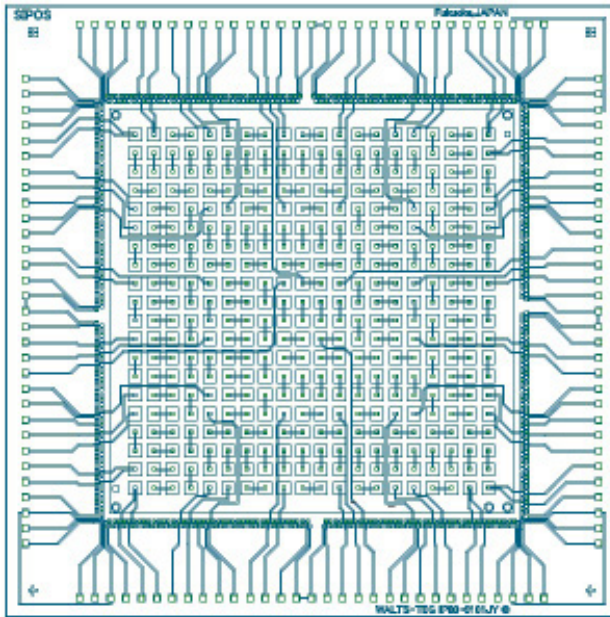

Wafer Size	8 inch
Wafer Thickness	725±25µm
Chip Size	10.0mm
Pad pitch	① 80µm Staggered (Inner pad) ② 300µm Full area (Center core) ③ 250 peripheral (Outer pad)
Function	Daisy Chain
Pad config	Peripheral and Full Area
Pad Size	① 58 µm ② 58 µm ③ 110 µm
Passivation opening	① 48 µm ② 48 µm ③ 100 µm
Scribe width	100µm
Number of Pad	① 648 pads ② 400 pads ③ 124 pads
Number of Chip	Cu pillar 256 chips ElectrolessNiAu 256 chips
Surface Spec of Electrode	Electroless Ni/Au plating

KIT CC80(T)-0106JY [MAP]

[for CC80-0101JY]

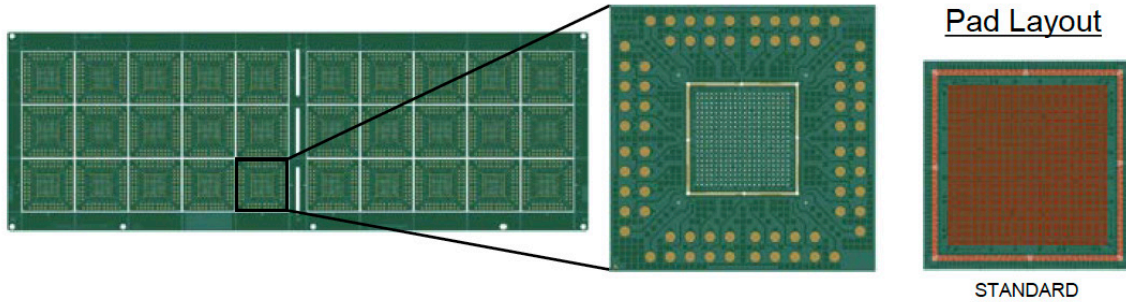

Specifications	CC80(T)-0106JY [MAP]
Structure	1-2-1 Build up Substrate
Outline	187.5mm×64.0mm×(0.36mmt)
Function	Daisy Chain
Lead Min L/S	32μm/48μm
Number of Electrode	1048 *Peripheral (648)/Full Area (400)
Pad Dimensions	φ0.75mm (SR opening : φ0.67mm)
Number of Measurement Electrode	72 pads
Surface Spec of Electrode	•Cu+OSP

KIT CC80CL-0100JY [MAP] [for CC80-0101JY]

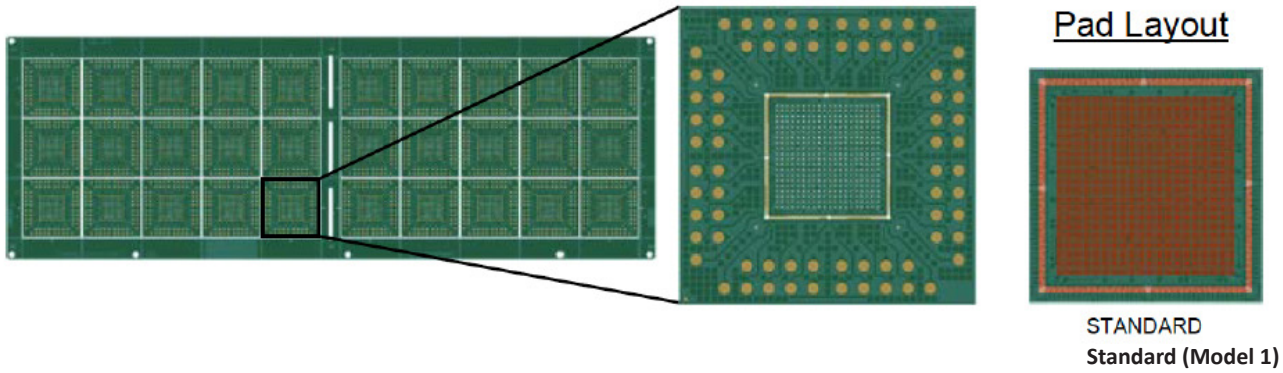

STANDARD
Standard (Model 1)

Specifications	CC80CL-0100JY-[MAP]
Structure	Coreless 3L
Outline	187.5mm×64.0mm×(0.158mmt)
Function	Daisy Chain
Lead Min L/S	32μm/48μm
Number of Electrode	1048 *Peripheral (648),Full Area (400)
Pad Dimensions	φ0.75mm (SR opening φ0.67mm)
Number of Measurement Electrode	72 pads
Surface Spec of Electrode	Cu Cu+OSP

CC80TSV-0101JY

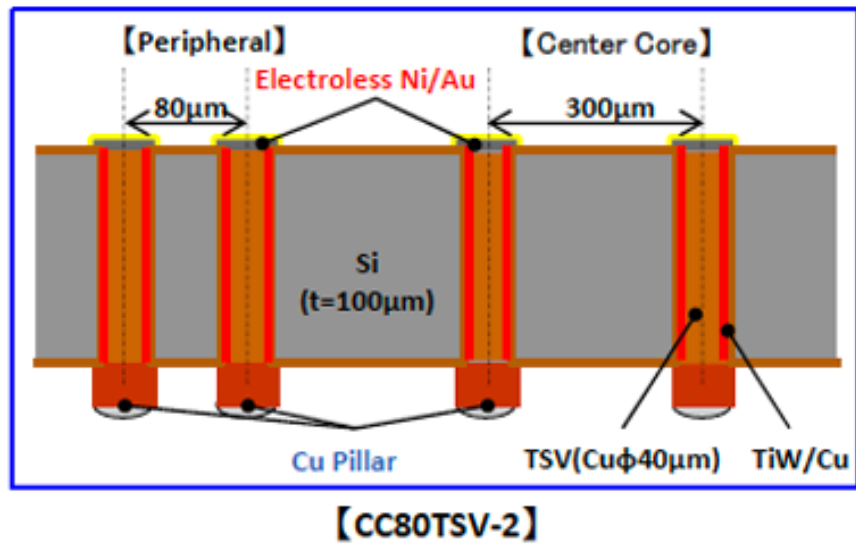
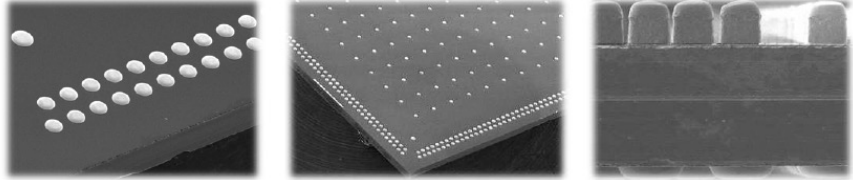
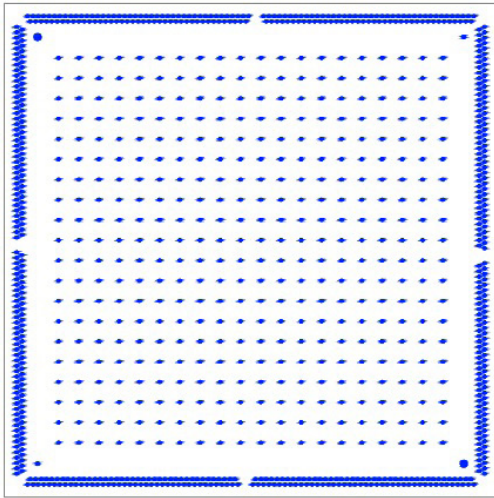

Specifications	CC80TSV-2	
Wafer Size	8 inch	
Wafer Thickness	100µm	
Chip Size	7.3mm■	
Pad pitch	80µm staggered (Peripheral) 300µm Full area (Center core)	
TOP Side	Electrode	Cu + SnAg
	Bump Size	φ42µm
	Bump Height	Cu20µm + SnAg15µm
BOTTOM Side	Electrode	Electroless Ni/Au plating
	Bump Size	Φ48µm
	Bump Height	8µm
Scribe width	120µm	

CONCEPT of CC80MarkIV SERIES

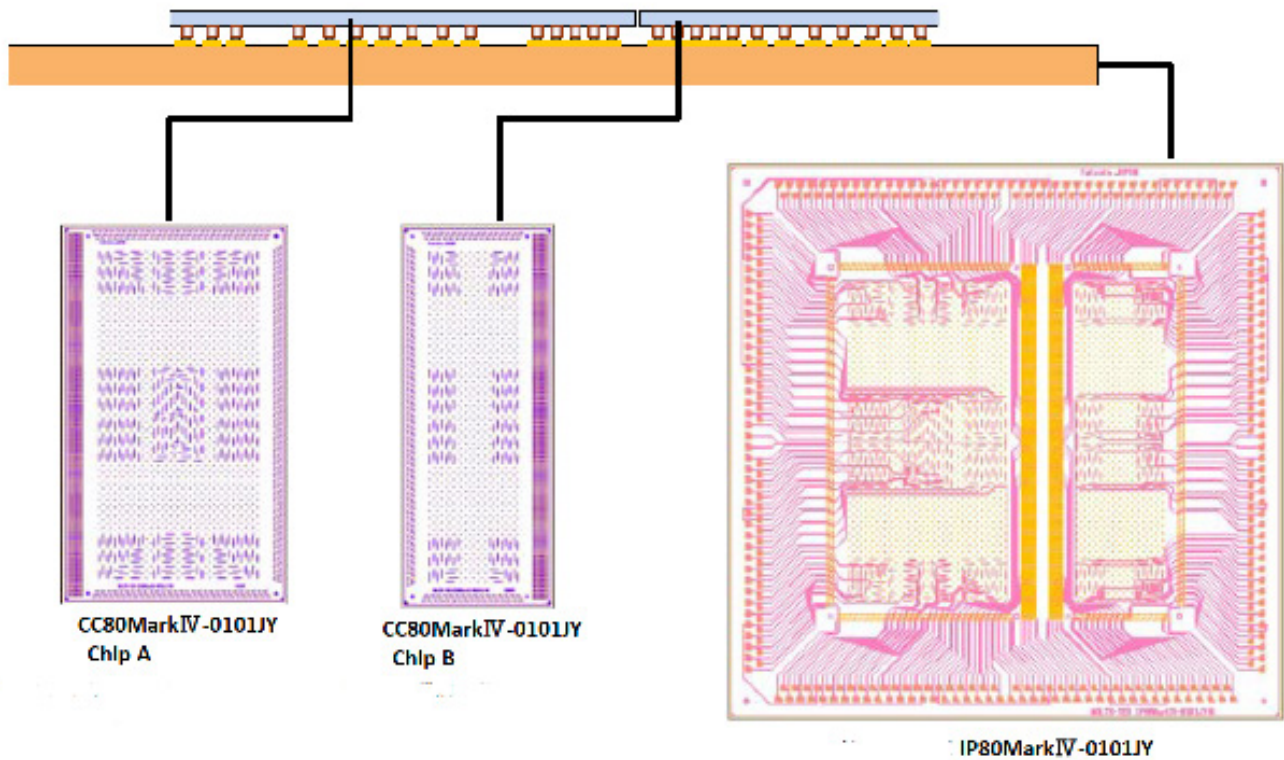

CC80MarkIV-0101JY (A/B)

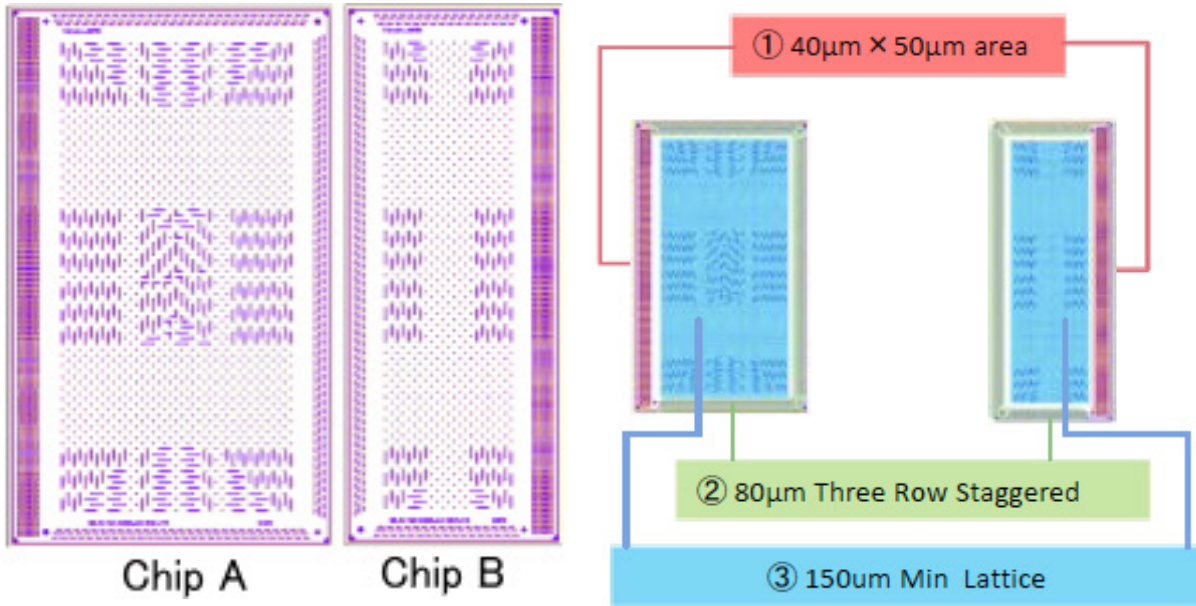

Wafer Size	8 inch	
Wafer Thickness	725±25µm	
Chip	A	B
Chip Size	6.0mm×10.0mm	4.0mm×10.0mm
Pad pitch	① 40µm [10Row] × 50µm [192Row] (Peripheral) ② 80µm staggered [3Row] (Center core) ③ 150µm Min Lattice	
Function	Daisy Chain	
Electrode/Height	Cu15µm+SnAg10µm	
Pad Size	① 30µm● ② 30µm● ③ 30µm●	
Passivation opening	12µm (Octagon)	
Bump Size	φ25µm	
Number of Bump/Pad	① 1920 bumps / 1920 pads ② 687 bumps / 687 pads ③ 1743 bumps / 1743 pads	① 1920 bumps / 1920 pads ② 531 bumps / 531 pads ③ 978 bumps / 978 pads
Scribe width	120µm	
Number of Chip	Chip A: 228 chips/wafer Chip B: 228 Chips/wafer	

IP80 MarkIV-0101JY Silicon Interposer [for CC80MarkIV-0101JY(A/B)]

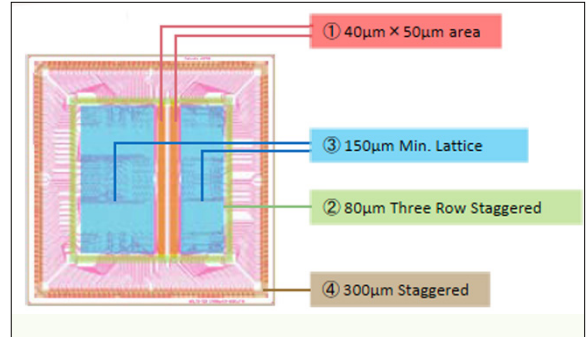
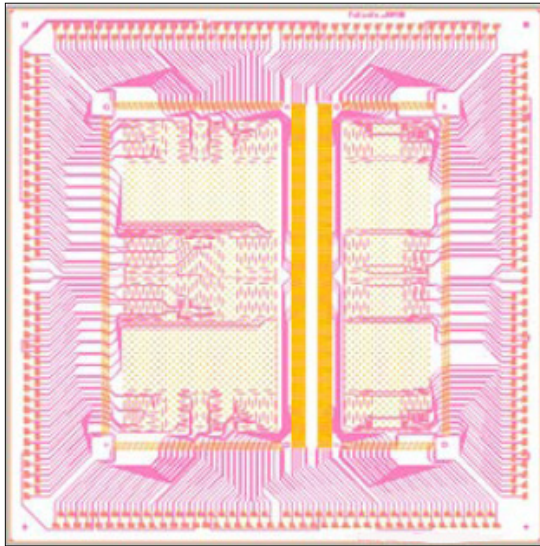

Wafer Size	8 inch
Wafer Thickness	725±25µm
Chip Size	15.0mm×15.0mm
Pad pitch	① 40µm (10Row)×50µm (192Row)×2(Peripheral) ② 80µm staggered (3Row) (Center core) ③ 150µm Min. Lattice ④ 300µm (Staggered)
Function	Daisy Chain
Electrode	Electroless Ni/Au plating
Pad Size	① 32µm● ② 32µm● ③ 32µm● ④ 150µm■
Passivation opening	① 26µm● ② 26µm● ③ 26µm● ④ 140µm■
Bump Size	① 27µm● ② 27µm● ③ 27µm● ④ 141µm■
Number of Bump/Pad	① 3840 bumps / 3840 pads ② 1172 bumps / 1172 pads ③ 2721 bumps / 2721 pads ④ 327 bumps / 329 pads
Scribe width	120µm
Number of Chip	97 chips/wafer
Number of Bump/Pad	① 3840 bumps / 3840 pads ② 1172 bumps / 1172 pads ③ 2721 bumps / 2721 pads ④ 327 bumps / 329 pads
Scribe width	120µm
Number of Chip	97 chips/wafer

WM40-0101JY

[for CC80MarkII WM-0101JY]

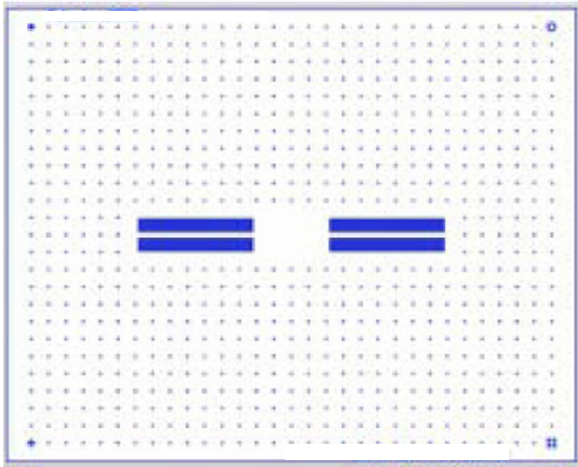

Top Side

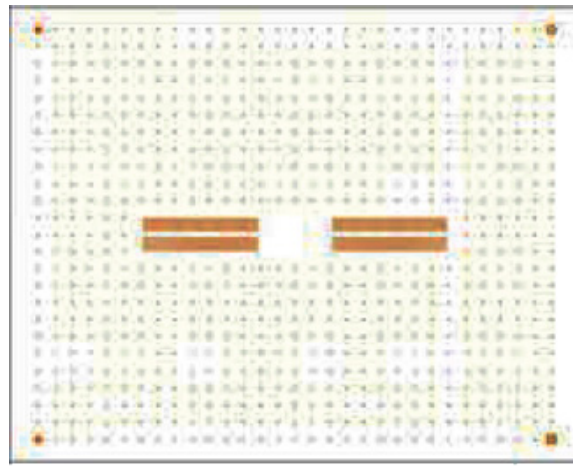

Bottom Side

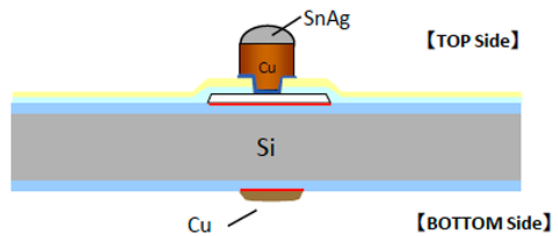
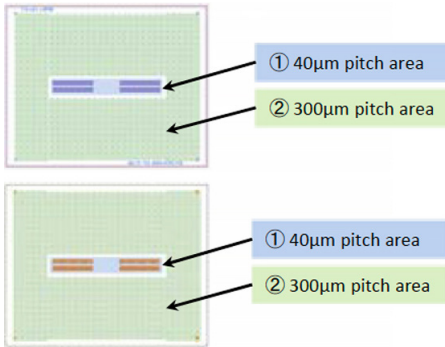

Specifications		
Wafer Size	8inch	
Wafer Thickness	50µm	
Chip Size	10mm×8mm	
Function		
TOP Side	Pad Size	35µm■
	Passivation Opening	10µm (Octagon)
	Number of Pad	① 1200 pads ② 714 pads
	Electrode	Cu Pillar Bump
	Bump Size	Φ20µm
	Bump Pitch	① 40µm ② 300µm
	Bump Height	Cu10µm + SnAg8µm
BOTTOM Side	Electrode	Cu post
	Number of Bump	① 1200 bumps ② 714 bumps
	Bump Size	Φ26µm
	Bump Pitch	① 40µm ② 300µm
	Bump Height	Cu 6µm
Number of Chip	312 chips/wafer	

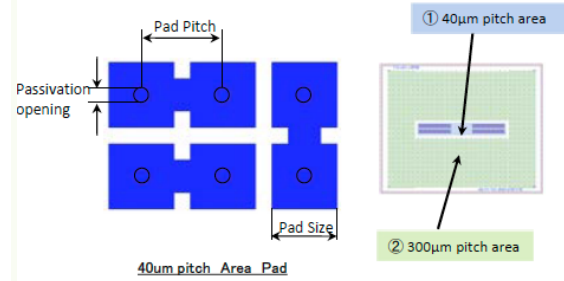
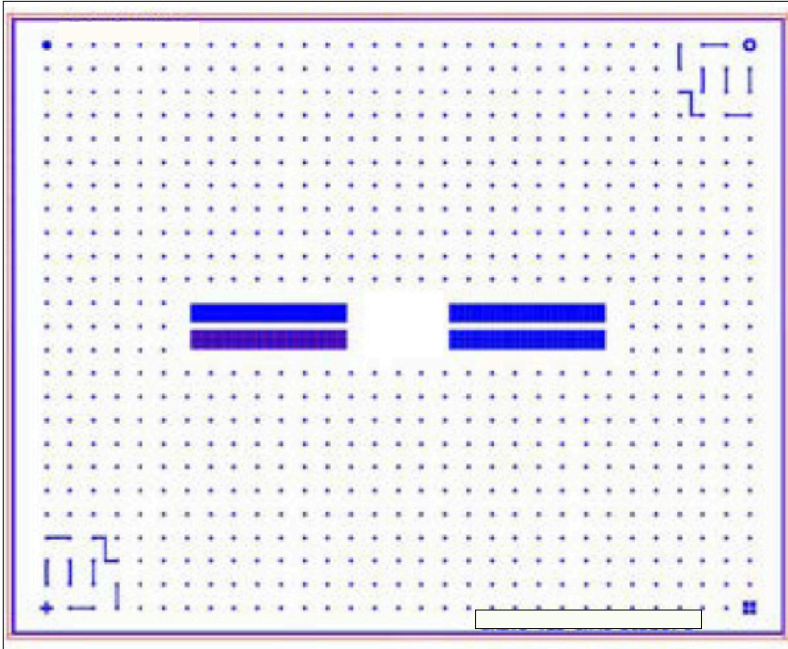

Specifications	
Wafer Size	8inch
Wafer Thickness	725±25µm
Chip Size	10mm×8mm
Function	Daisy Chain
Pad Size	32µm■
Passivation Opening	7µm (Octagon)
Number of Pad	① 1200 pads ② 714 pads
Electrode	Cu Pillar Bump
Bump Size	Φ20µm
Bump Pitch	①40µm ②300µm
Bump Height	Cu15µm + SnAg8µm
Number of Chip	312 chips/wafer

WM40-0103JY

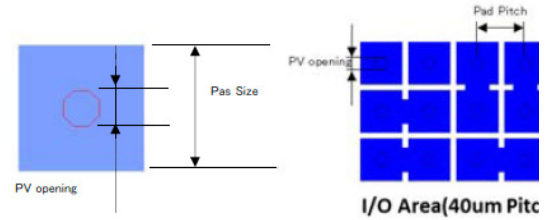
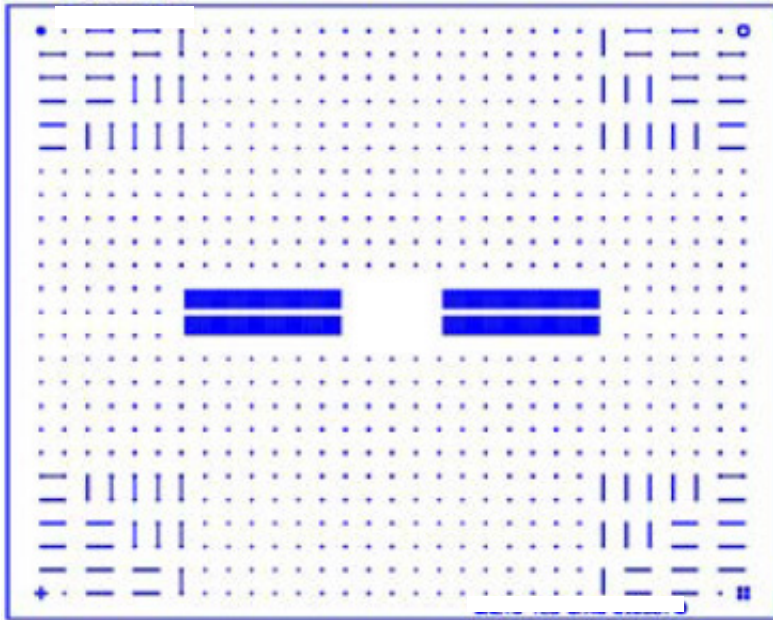

Specifications	
Wafer Size	8inch
Wafer Thickness	725±25µm
Chip Size	10.0mm×8.0mm
Function	Daisy Chain
Pad Size	35µm■
Passivation Opening	10µm (Octagon)
Number of Pad	I/O area : 40um pitch ×1200 pads Dummy area : 300um pitch×714pads
Electrode	Cu pillar
Bump Size	Φ20µm
Bump Pitch	①40µm ②300µm
Bump Height	Cu10um+SnAg10um
Number of Chip	312 chips/wafer

IPWM40-0101JY

[for WM40-0103JY]

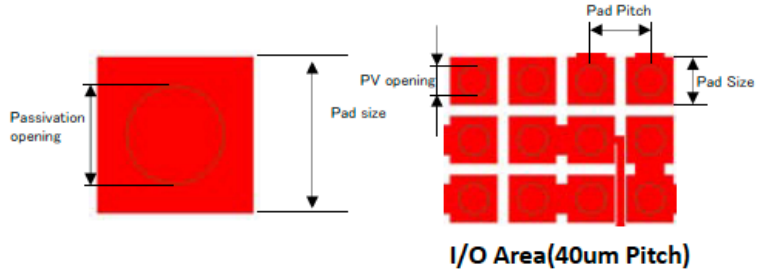
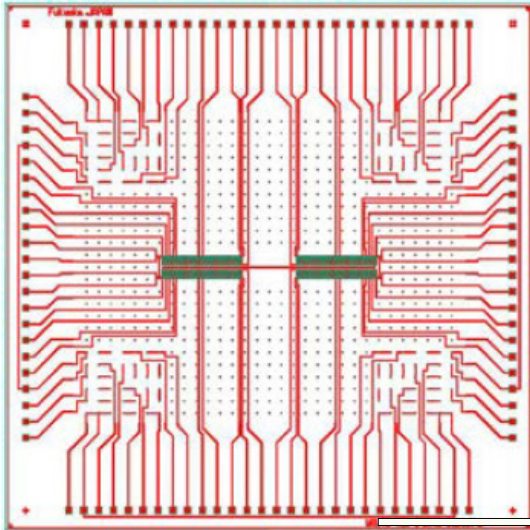

Specifications	
Wafer Size	8inch
Wafer Thickness	725±25μm
Chip Size	13.0mm×13.0mm
Function	Daisy Chain Bump Short Check Breakdown Voltage Check between Bumps
Pad Size	32μm■
Passivation Opening	φ20μm
Number of Pad	①1200 pads ②714pads Probe Pad 72pads (Same pad area as WM40-0103JY)
Electrode	Electroless Ni/Au plating
Bump Size	Φ25μm
Bump Pitch	①40μm ②300μm
Bump Height	2.5μm
Number of Chip	148 chips/wafer

CONCEPT of HBM SERIES

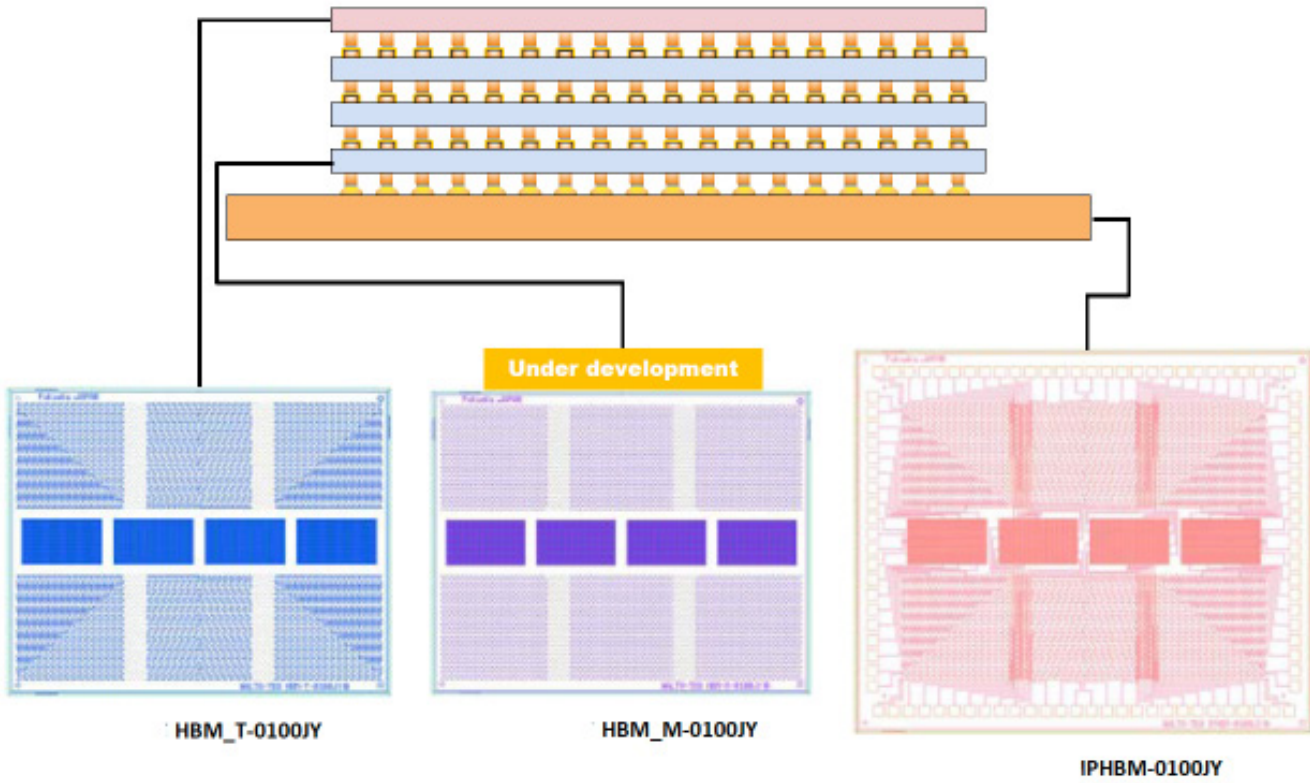

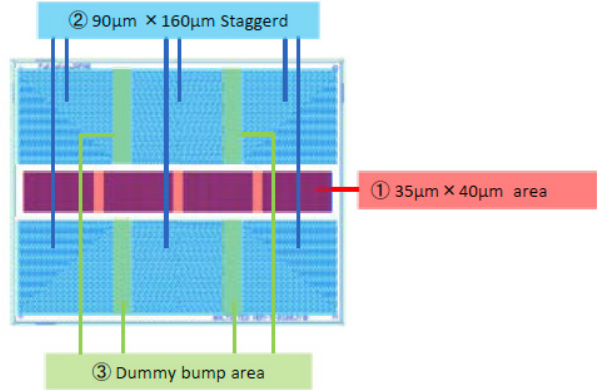
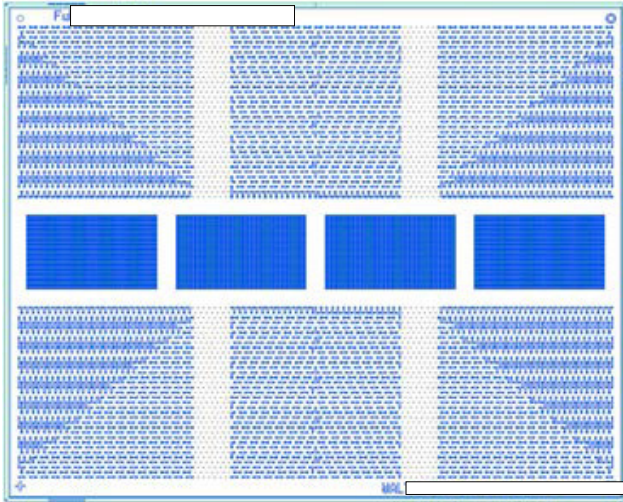

Wafer Size	8 inch
Wafer Thickness	725±25μm
Chip Size	10.0mm×8.0mm
Pad pitch	① 35μm×40μm(I/O area) ② 90μm x 160μm(Staggerd area)
Function	Daisy Chain
Electrode	Cu pillar
Pad Size	①27μm■ ②27μm■
Passivation opening	①8μm● ②8μm●
Bump Size	①16μm● ②16μm● ③16μm●
Number of Pad	①7200 pads(I/O area) ②6544 pads(Staggerd area)
Number of Bump	①7200 bumps (I/O area) ②6544 bumps (Staggerd area) ③912 bumps (Dummy bump area)
Scribe width	120μm
Number of Chip	312 chips/wafer

IPHBM-0100JY

Silicon Interposer [for HBM_T-0100JY]
[for HBM_M-0100JY]

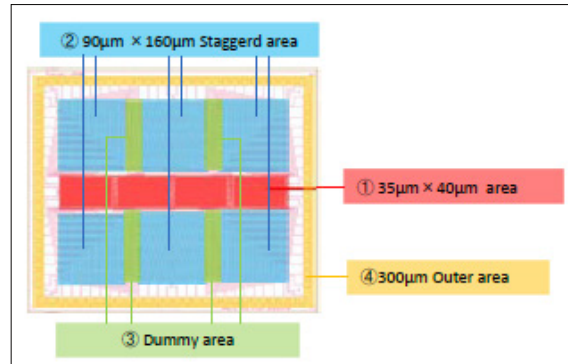
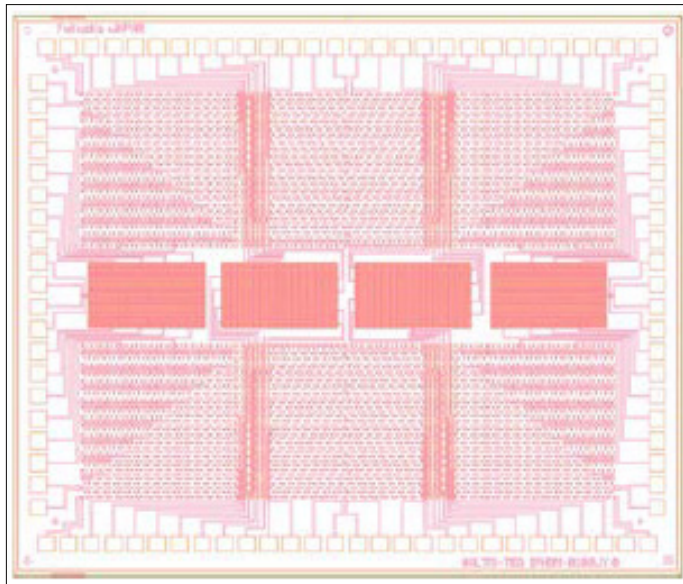

Wafer Size	8 inch
Wafer Thickness	725±25µm
Chip Size	12.0mm×10.0mm
Pad pitch	<ul style="list-style-type: none"> ① 35µm×40µm(I/O area) ② 90µm×160µm(Staggerd area) ③ 90µm×160µm(Dummy area) ④ 300µm (Outer area)
Function	Daisy Chain
Electrode	Electroless Ni/Au plating
Pad Size	①27µm■ ②27µm■ ③27µm■ ④300µm■
Passivation opening	①18µm● ②18µm● ③18µm● ④280µm■
Bump Size	①23µm● ②23µm● ③23µm● ④285µm■
Number of Pad	<ul style="list-style-type: none"> ① 7200 pads(I/O area) ② 6544 pads(Staggerd area) ③ 912 pads(Dummy area) ④ 96 pads(Outer area)
Scribe width	120µm
Number of Chip	204 chips/wafer

FC150LC-0102JY

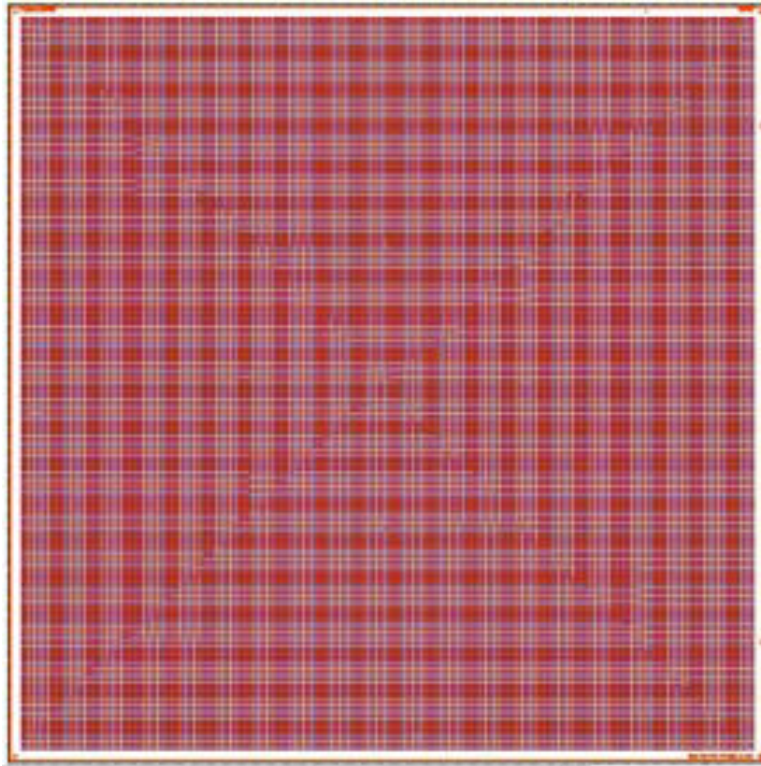

Specifications	
Wafer size	φ300mm
Wafer Thickness	775±25μm
Chip size	25mm * 25 mm (Scribe center to center)
Pad (bump) pitch	150μm
Function	Daisy Chain
Electrode	Cu pillar (Cu30μm+SnAg15μm)
Bump size	φ75μm
Passivation opening	40μm (octagon)
Polyimide opening	φ40μm
Scribe line width	100μm
Number of chip	89 chips/wafer
Number of pad	25,921 pads (161x161 Matrix)

KIT FC150LC(S)-0303JY

[for FC150LC-0102JY]

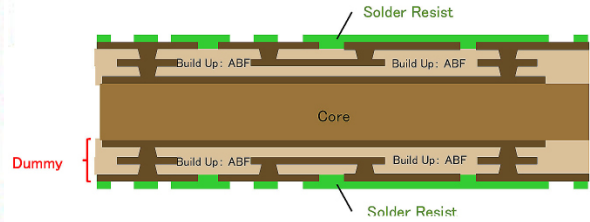
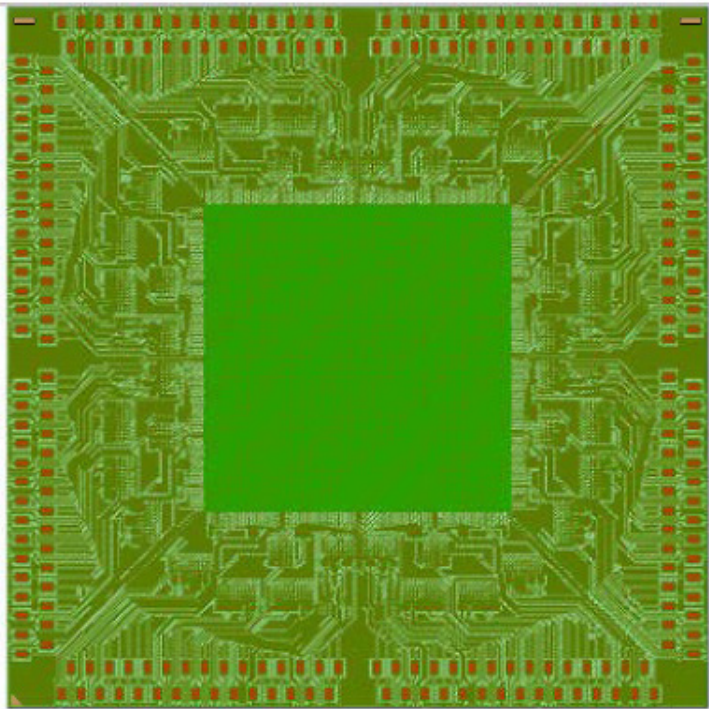

Specifications	
Structure	2-2-2 Build up Substrate
Outline	55mm×55mm×(0.66mm)
Function	Daisy Chain / Connection Resistance
Pad Dimension	0.75mm×1.1mm (SR opening: 0.65mm×1.0mm)
Number of Measurement Pad	240 pads
FCA area	Pad pitch: 150μm pitch full array SR opening φ85μm Number of pad: 25,921 pads (161×161Matrix)
Electrode	Electroless plating : Ni/Pd/Au Ni/Pd/Au+SnAgCu

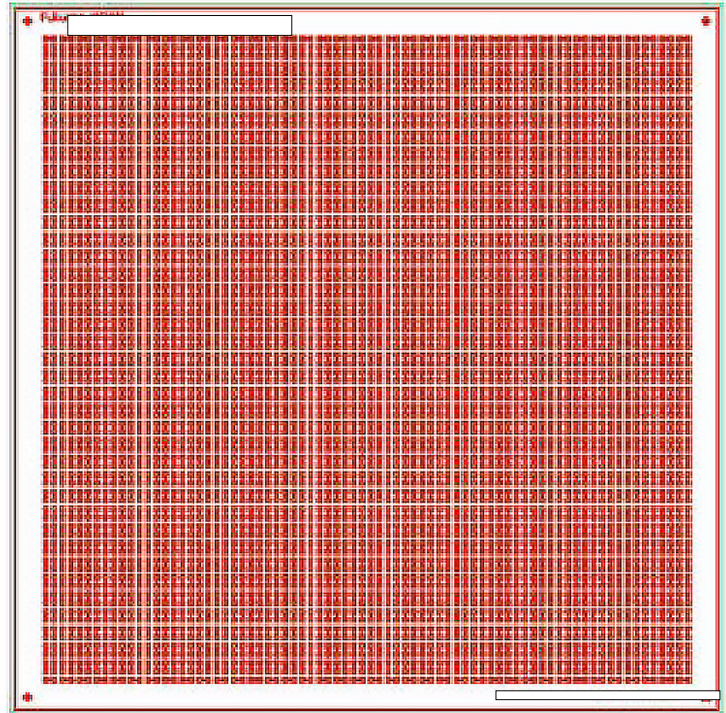
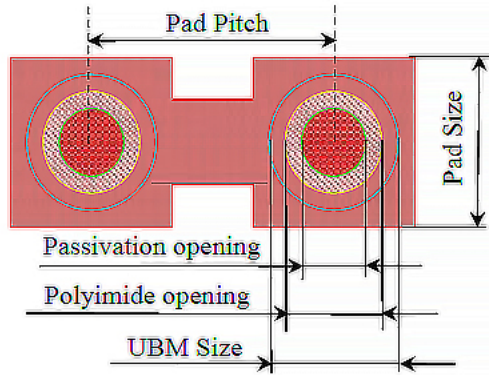

Specifications	
Wafer Size	8inch
Wafer Thickness	725±25µm
Chip Size	10.0mm■
Bump pitch	120µm
Function	Daisy Chain
Pad config	Area
Electrode	Cu Pillar
Pad Size	80µm■
Passivation opening	φ20µm
Polyimide opening	φ40µm●
UBM Size	φ65µm●
Bump Size	φ60µm●
Scribe width	100µm
Number of Pad	5776pads/chip(76×76)
Number of Chip	208 chips/wafer

KIT FC120

[for FC120JY]

【KIT 01A 120P(S)-10】

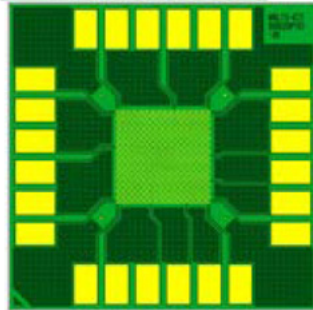

【KIT FC120(S) (2 × 2)】

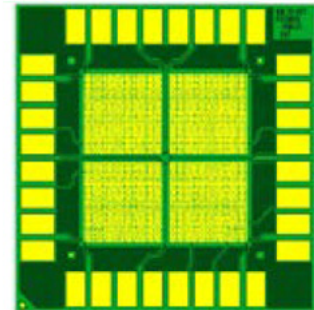

Name of commodity	01A120P(S)-10	FC120(S)-0101JY
Specifications	1×1	2×2
Structure	Rigid Substrate (Both)	Rigid Substrate (Both)
Outline	30.0mm×30.0mm× (0.972mmt)	35.0mm×35.0mm× (0.972mmt)
Function	Daisy Chain	Daisy Chain
Land Size	φ0.095mm●	φ0.095mm●
Number of Lead	5776(76×76)	23104(5776/chip×4)
SR opening	φ70μm●	φ70μm●
Number of Measurement Pad	24 pads	32 pads
Daisy Chain	Center Area 18×20 Matrix Corner Area 19×20 four Matrix	Center Area 38×40 Matrix Corner Area 19×20 four Matrix
Surface Spec of Electrode	Cu + OSP (option Solder Coat)	Cu + OSP (option Solder Coat)
*OSP: Organic Solderability Preservatives		

FC150JY FC150SCJY

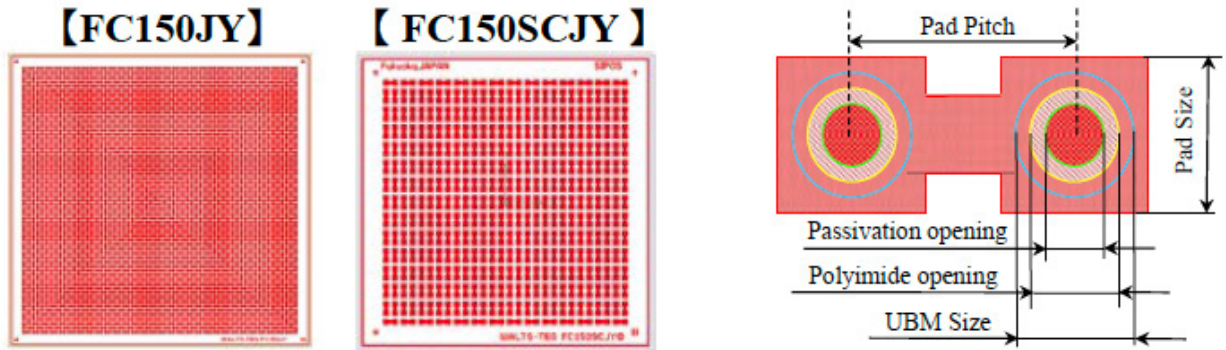

Specification	FC150JY		FC150SCJY	
	A	B	A	B
Wafer Thickness	725±25µm	725±25µm	725±25µm	725±25µm
Wafer Size	8 inch	8 inch	8 inch	8 inch
Chip Size	10.0mm■	10.0mm■	5.02mm■	5.02mm■
Bump pitch	150µm	150µm	150µm	150µm
Function	Daisy Chain	Daisy Chain	Daisy Chain	Daisy Chain
Pad config	Area	Area	Area	Area
Electrode	Ball Mounted Solder Bump	Cu Pillar	Ball Mounted Solder Bump	Cu Pillar
Pad Size	100µm■	100µm■	100µm■	100µm■
Passivation opening	φ40µm●	φ40µm●	φ40µm●	φ40µm●
Polyimide opening	φ50µm●	φ50µm●	φ50µm●	φ50µm●
UBM Size	φ80µm●	φ75µm●	φ80µm●	φ80µm●
Bump Size	φ90µm●	φ75µm●	φ90µm●	φ80µm●
Scribe width	100µm	100µm	100µm	100µm
Number of Pad	3721pads/chip(61×61)	3721pads/chip(61×61)	784 pads/chip (28×28)	784 pads/chip (28×28)
Number of Chip	208 chips/wafer	208 chips/wafer	832 chips/wafer	832 chips/wafer

KIT FC150

[for FC150JY]

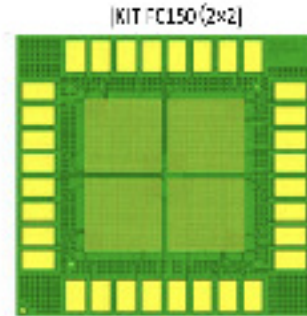
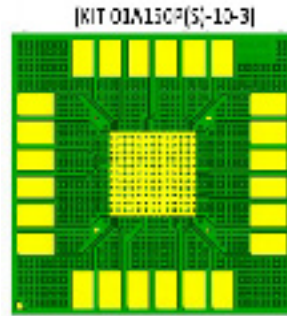

Name of commodity	01A150P(S)-10-3	FC150(S)-0106JY 2×2
Specifications	1×1	2×2
Structure	Rigid Substrate (Both)	Rigid Substrate (Both)
Outline	30.0mm×30.0mm× (0.976mmt)	35.0mm×35.0mm×(0.976mmt)
Function	Daisy Chain	Daisy Chain
Land Size	φ0.12mm●	φ0.12mm●
Number of Lead	3721 (61×61)	14884(3721/chip×4)
SR opening	φ80μm●	φ80μm●
Number of Measurement Pad	24 pads	32 pads
Daisy Chain	Center Area 16×15 Matrix Corner Area 15×15 four Matrix	Center Area 30×30 Matrix Corner Area 30×30 four Matrix
Surface Spec of Electrode	Cu + OSP (option Solder Coat) Electroless Ni/Au plating	Cu + OSP (option Solder Coat)
*OSP: Organic Solderability Preservatives		

【Glass-type】

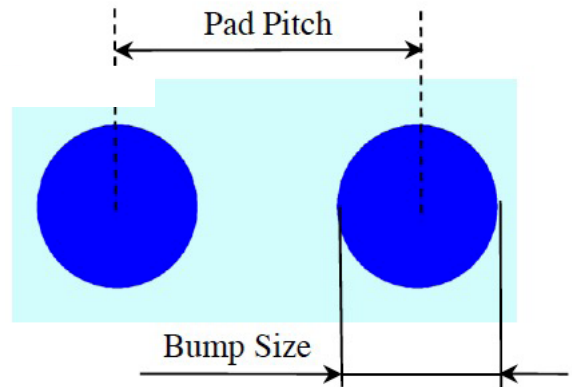
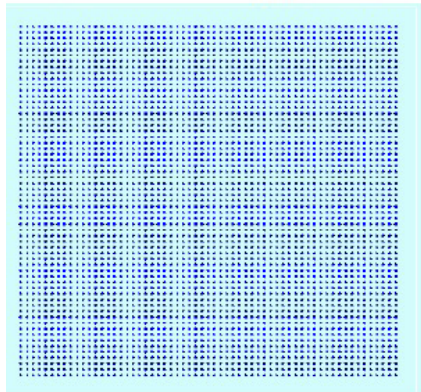

Specifications	FC150JY Glass	FC200JY Glass
TYPE	B	B
Wafer Thickness	700±25µm	700±25µm
Wafer Size	8 inch	8 inch
Chip Size	10mm ■	10mm ■
Bump pitch	150µm	200µm
Function	—	—
Pad config	Area	Area
Electrode	Cu Pillar	Cu Pillar
Pad Size	—	—
Passivation opening	—	—
Polyimide opening	—	—
UBM Size	φ75µm ●	φ90µm ●
Bump Size	φ75µm ●	φ90µm ●
Scribe width	—	—
Number of Pad	—	—
Number of Chip	208 chips/wafer	228 chips/wafer

FC200JY FC200SCJY

[FC200JY]

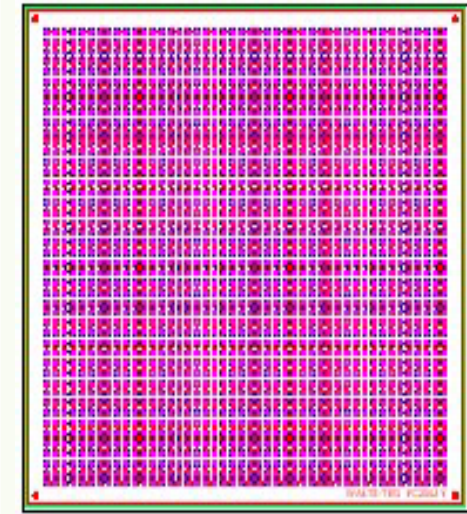

[FC200SCJY]

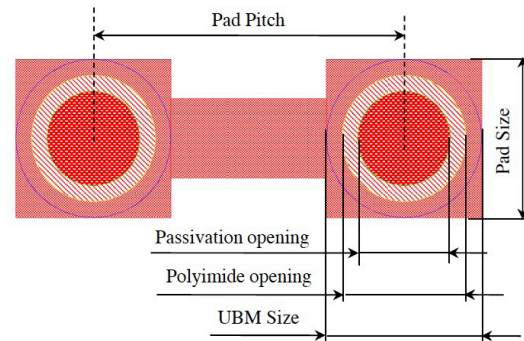

TYPE	FC200JY		FC200SCJY	
	A	B	A	B
Wafer Size	8 inch	8 inch	8 inch	8 inch
Wafer Thickness	725±25µm	725±25µm	725±25µm	725±25µm
Chip Size	10.0mm■	10.0mm■	5.02mm■	5.02mm■
Bump pitch	200µm	200µm	200µm	200µm
Function	Daisy Chain	Daisy Chain	Daisy Chain	Daisy Chain
Pad config	Area	Area	Area	Area
Electrode	Ball Mounted Solder Bump	Cu Pillar	Ball Mounted Solder Bump	Cu Pillar
Pad Size	100µm■	100µm■	100µm■	100µm■
Passivation opening	φ60µm●	φ60µm●	φ60µm●	φ60µm●
Polyimide opening	φ70µm●	φ70µm●	φ70µm●	φ70µm●
UBM Size	φ100µm●	φ90µm●	φ100µm●	φ90µm●
Bump Size	φ100µm●	φ90µm●	φ100µm●	φ90µm●
Scribe width	100µm	100µm	100µm	100µm
Number of Pad	2116 pads/chip (46×46)	2116 pads/chip (46×46)	484 pads/chip (22×22)	484 pads/chip (22×22)
Number of Chip	228 chips/wafer	228 chips/wafer	832 chips/wafer	832 chips/wafer

KIT FC200

[for FC200JY]

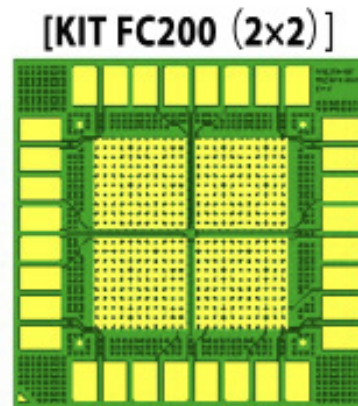
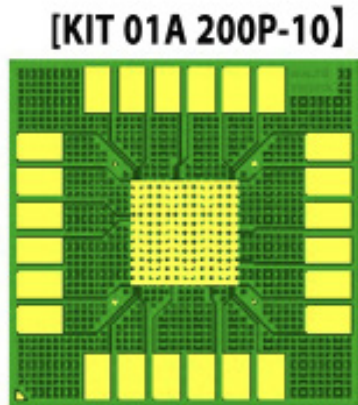

Name of commodity	KIT 01A200P-10	KIT FC200-0102JY 2x2
Specifications	1X1	2X2
Structure	Rigid Substrate (Both)	Rigid Substrate (Both)
Outline	30.0mmX30.0mmx(0.97mmt)	35.0mmX35.0mmxX0.87mmt)
Function	Daisy Chain	Daisy Chain
Land Size	φ0.14mm●	φ0.14mm●
Number of Lead	2116 (46X46)	8464(2116/chipx4)
Vehicle	10mmX10mm 200μm pitch area	20mmX20mm 200μm pitch area
SR opening	φ95μm●	φ95μm●
Number of Measurement Pad	24 pads	32 pads
Daisy Chain	Center Area 12X12 Matrix Corner Area 12X11 four Matrix	Center Area 20X18 Corner Area 12X11 four Matrix
Surface Spec of Electrode	Cu + OSP (option Solder Coat)	Cu + OSP (option Solder Coat)
*OSP: Organic Solderability Preservatives		

FBW Series

Full Bump Wafer *Dicing Size is Free*

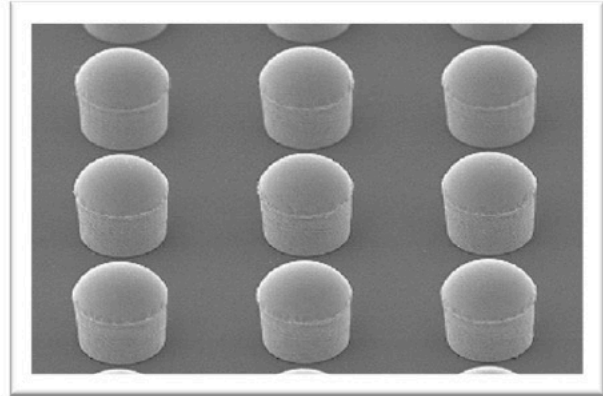
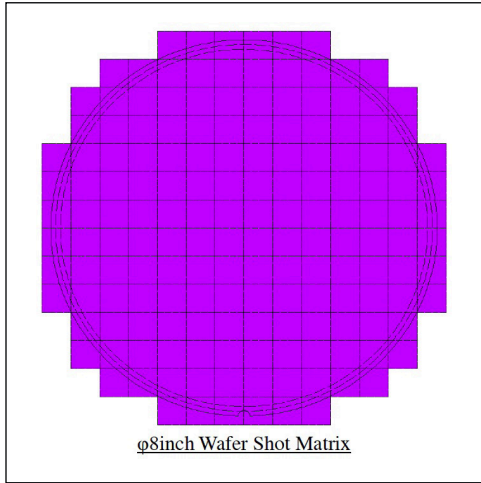

Cu Pillar Bump

Specifications	FBW200A-0000JY	FBW150A-0000JY	FBW100A-0000JY	FBW80A-0000JY	FBW40A-0001JY	FBW20A-0000JY	FBW10-0000JY
Wafer Size	12 inch	12 inch	12 inch	12 inch	12 inch	12 inch	8 inch
Wafer Thickness	775±25µm	775±25µm	775±25µm	775±25µm	775±25µm	775±25µm	725±25µm
Bump Pitch	200µm	150µm	100µm	80µm	40µm	20µm	10µm
Electrode	Cu Pillar	Cu Pillar	Cu Pillar	Cu Pillar	Cu Pillar	Cu Pillar	Cu Pillar
Bump Size	φ90µm	φ75µm	φ50µm	φ40µm	φ20µm	φ10µm	φ5µm
Cu Height	2.5µm~50µm	2.5µm~50µm	2.5µm~55µm	2.5µm~30µm	2.5µm~30µm	Cu4µm	-
SnAg Height	30µm~45µm	24µm~35µm	15µm~25µm	12µm~20µm	8µm~10µm	-	-
Total Max Height	80µm	75µm	70µm	45µm	30µm	Cu4µm	Cu6µm

Applications
 Chiplet Evaluation
 Molded Under Fill Evaluation
 Wafer to Wafer Bonding Evaluation

Full Bump Wafer FBW50

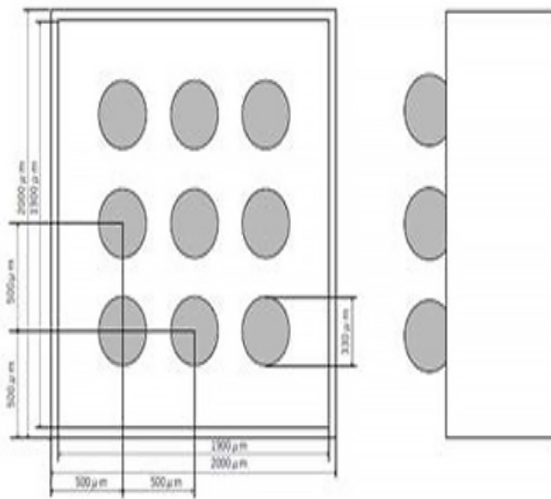
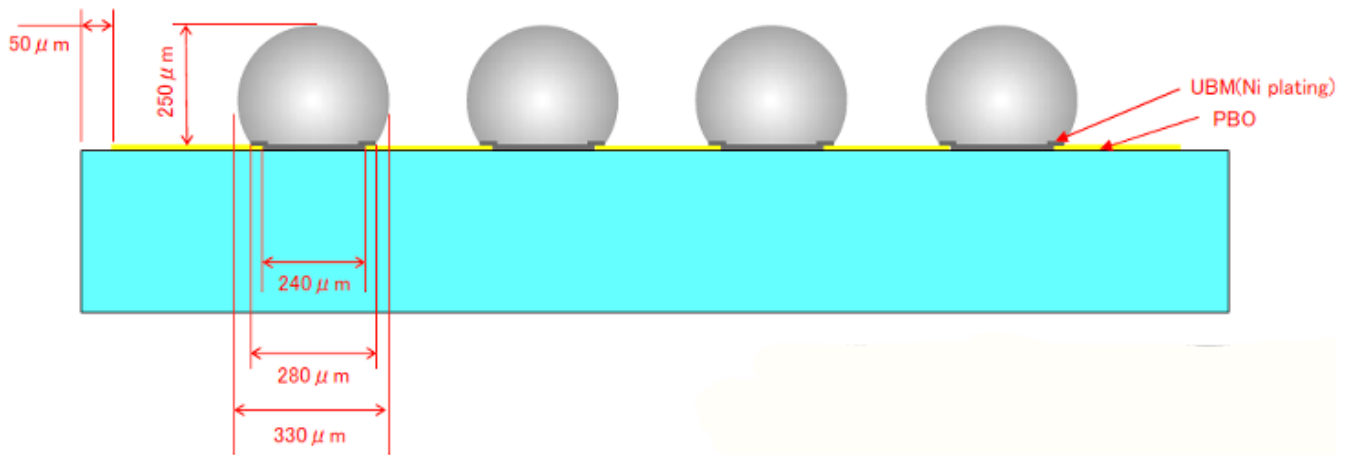

Items	Specification
Wafer Size	8inch(Φ200mm)
Bump Area	Φ193mm
Wafer Thickness	725um
Bump Pitch	500um
Bump Size	Φ330um
Bump Height	250um
Bump Material	Solder (SAC305)
Chip Pitch	2000um
Scribe Line Width	100um
PBO Thickness	4um
PBO Diameter	240um
UBM Thickness	3um
UBM Diameter	280um

Produced by **maxell**
Within the Future

WLP TEG

(0.5mm pitch, 0.4mm pitch & 0.3mm pitch)

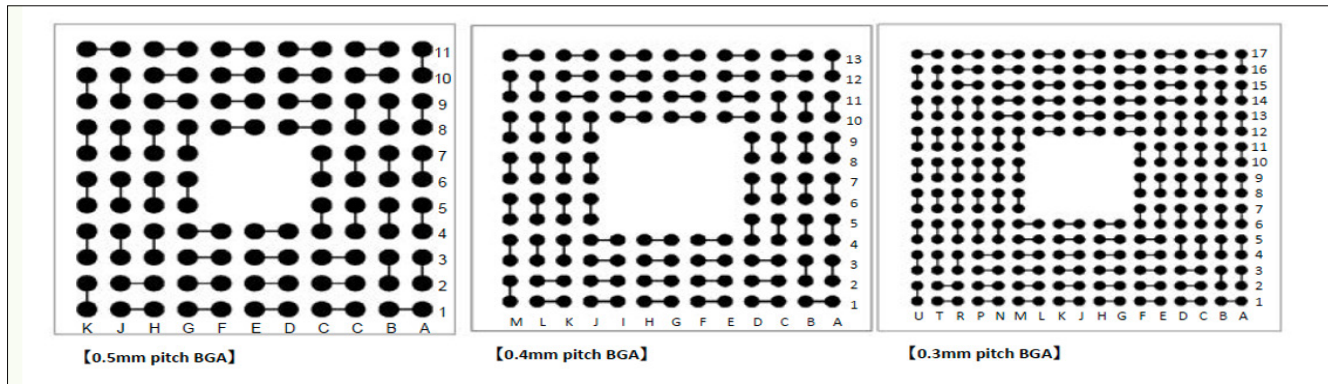

WLP TEG	0.5mm pitch BGA	0.4mm pitch BGA	0.3mm pitch BGA
Wafer Size	8 inch	8 inch	8 inch
Wafer Thickness	400±20µm	400±20µm	400±20µm
Chip Size	6.0mm■	6.0mm■	6.0mm■
BGA pitch	500µm	400µm	300µm
Function	Daisy Chain	Daisy Chain	Daisy Chain
Electrode	Ball Mounted Solder Bump	Ball Mounted Solder Bump	Ball Mounted Solder Bump
Bump Size	φ300µm	φ260µm	φ200µm
Line width	25µm	25µm	20µm
Number of Pin	112 pins/chip	144 pins/chip	264 pins/chip
Number of Chip	714 chips/wafer	714 chips/wafer	712 chips/wafer

KIT WLP(S)300P/400P -2

[for WLP TEG (0.4mm pitch & 0.3mm pitch)]

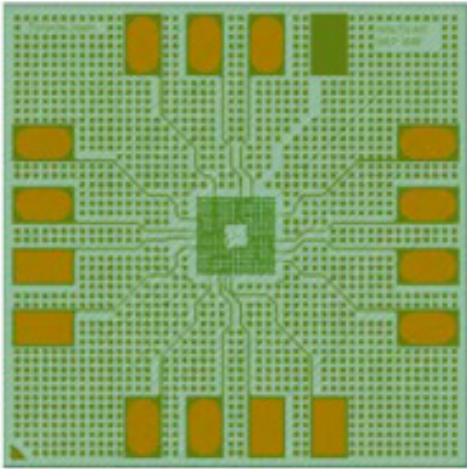

[KIT WLP(S) 300P-2 (Top Side)]

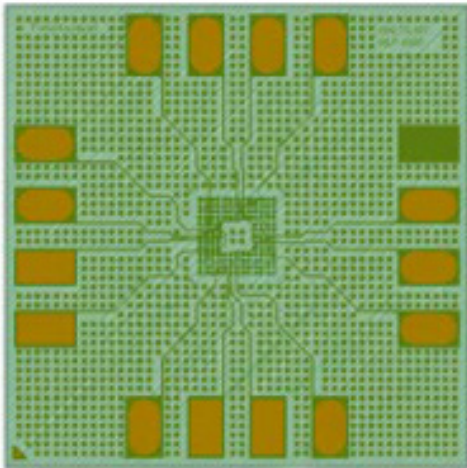

[KIT WLP(S) 400P-2 (Bottom Side)]

Specifications	KIT WLP(S)300P/400P-2	
Structure	1-2-1 Build up Substrate	
Outline	30.0mm×30.0mm×(0.978mmt)	
Function	Daisy Chain	
Number of Electrode	WLP300	264 leads
	WLP400	144 leads
Pad Dimension	2.4×4.0mm (SR opening: 2.2×3.8mm)	
Number of Measurement Pad	15 pads	
Electrode	Electroless Ni/Au plating	

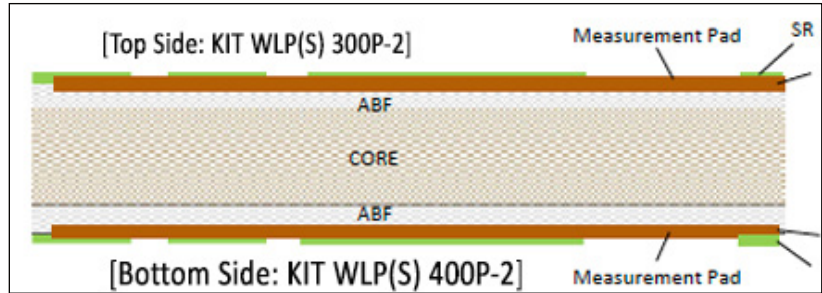

WLP

(Free Size Cut TEG : TEG0306,
TEG03507, TEG0408, TEG0510)

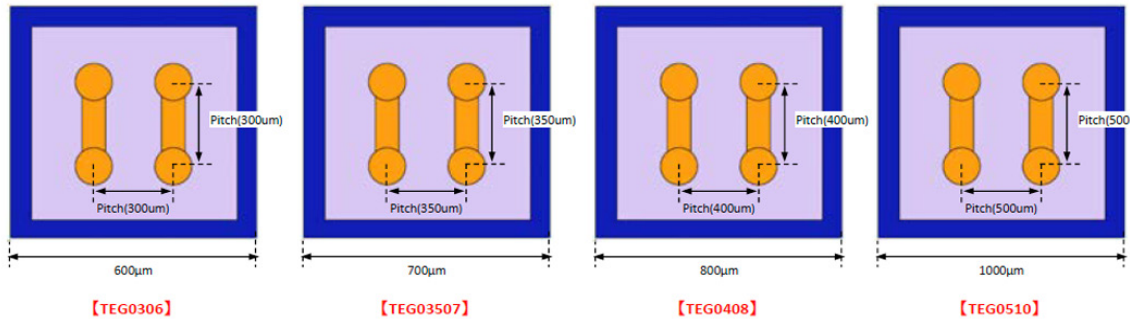

Free Size Cut TEG		TEG0306	TEG03507	TEG0408	TEG0510
Wafer Size		8 inch	8 inch	8 inch	8 inch
Wafer Thickness		400μm (or more)	400μm (or more)	400μm (or more)	400μm (or more)
Cut Size (Scribe Line Included)	Min.	600μm×600μm	700μm×700μm	800μm×800μm	1000μm×1000μm
Pad Pitch		300μm	350μm	400μm	500μm
Function		Daisy Chain	Daisy Chain	Daisy Chain	Daisy Chain
Electrode		Ball Mounted Solder Bump	Ball Mounted Solder Bump	Ball Mounted Solder Bump	Ball Mounted Solder Bump
Bump Size		Φ205μm	φ225μm	φ260μm	φ315μm
Number of Chip		79,257 chips/wafer	58,490 chips/wafer	44,161 chips/wafer	28,212 chips/wafer

STAC-0101JY

(for Stress & Thermal Resistance Analysis)

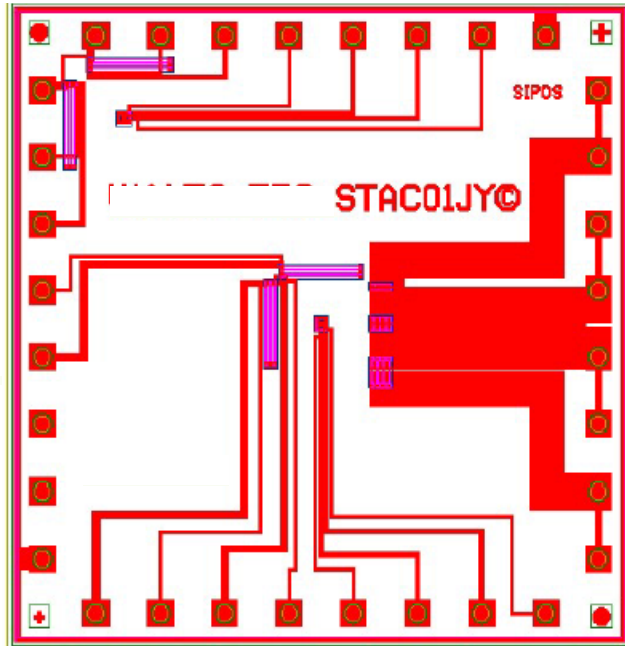

Specifications	
Wafer Size	6inch(Orientation Flat)
Wafer Thickness	550±25μm
Chip Size	3.0mm■
Pad Pitch	300μm
Function	Stress Analysis by Piezoresistance Thermal Analysis by Diode Heat Generation by Resistance
Electrode	Al pad Cu Pillar Bump Solder Bump Au Bump
Pad Size	120μm■
Passivation Opening	70μm (Octagon)
Polyimide Opening	φ90μm
Scribe Line Width	80μm
Number of Pad	32pads
Number of Chip	1596chips/wafer
Option	Back Side Metallization

KIT STAC(S)-0202JY

[for STAC-0101JY]

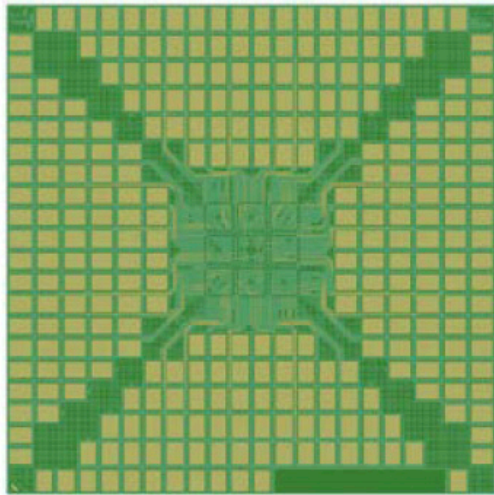

TOP SIDE VIEW (for 1 × 1chip, 3 × 3chip)

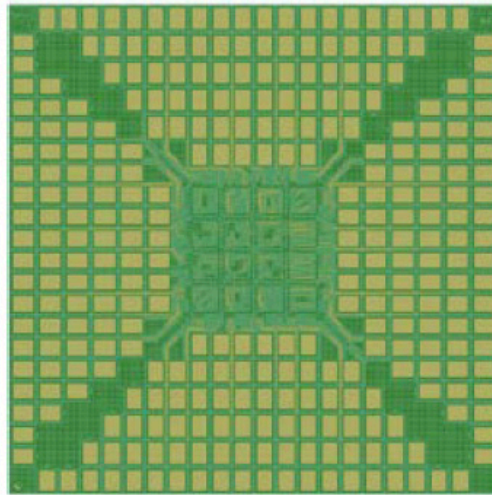

BOTTOM SIDE VIEW (for 2 × 2chip, 4 × 4chip)

Specifications	KIT STAC(S)-0202JY
Outline	45mm×45mm×(0.578mmt)
Function	—
FCA Area	Pad Pitch: 300μm pitch SR Opening: φ110μm
Electrode	●Ni/Pd/Au

STACTEG-150FA-0101JY STACTEG-300FA-0101JY

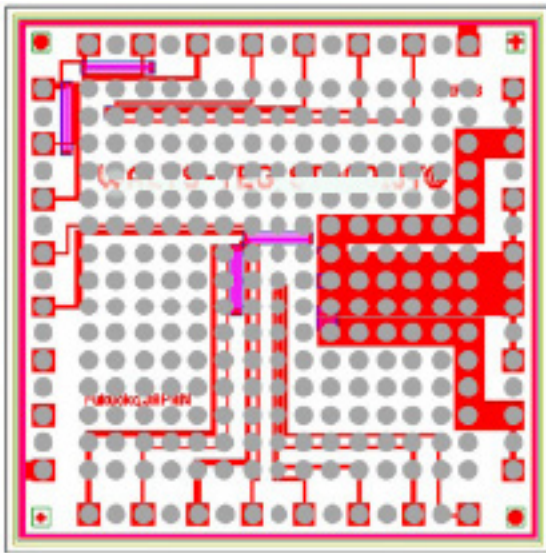

【STACTEG-150FA】

Specifications	STACTEG-150FA	STACTEG-300FA TEG
Base Wafer	STAC-0101JY	STAC-0101JY
Electrode	Ni + SnAg Bump	Cu Pillar Bump
Bump Pitch	150 μ m	300 μ m
Bump Size	ϕ 110 μ m	ϕ 110 μ m
Bump Height	Ni5 μ m+SnAg75 μ m	Cu50 μ m+SnAg10 μ m
Passivation Opening	70 μ m (Octagon)	70 μ m (Octagon)
Polyimide Opening	ϕ 90 μ m	ϕ 90 μ m
Number of Pad	32 pads	32 pads
Number of Bump	32 bumps + 253 Dummy bumps	32 bumps + 64 Dummy bumps
Number of Chip	1596chips/wafer	1596chips/wafer
Option	Back Side Metallization	Back Side Metallization

HPW-0101JY

(for Thermal Resistance Analysis at High Power)

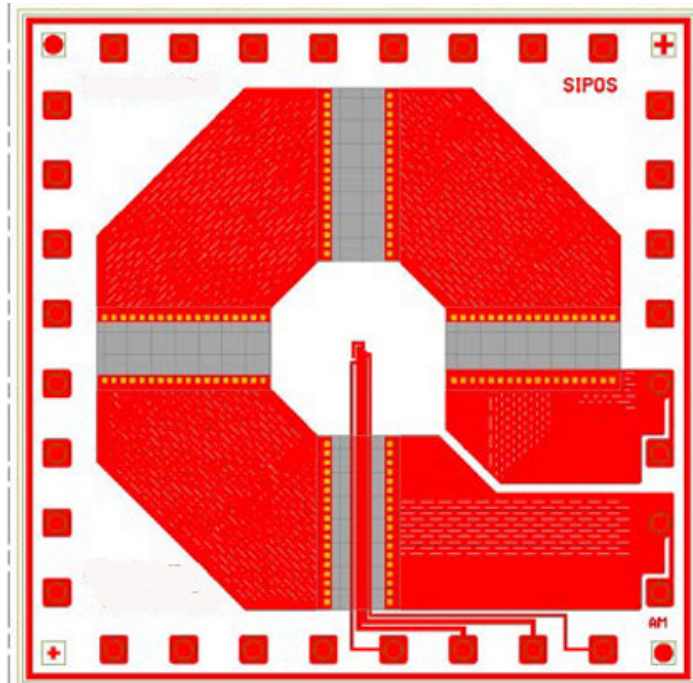

Specifications	
Wafer Size	8inch (Notch)
Wafer Thickness	725±25µm
Chip Size	3.0mm ■
Pad Pitch	300µm
Pad Size	120µm■
Passivation Opening	70µm (Octagon)
Polyimide Opening	φ90µm
Scribe Line Width	80µm
Function	Thermal Analysis by Diode Heat Generation by Resistance
Electrode	Al pad Cu Pillar Bump Solder Bump Au Bump
Number of Pad	32pads
Number of Chip	2964chips/wafer
Maximum Output	Max. 14.5W/Chip
Option	Back Side Metallization

HPWTEG-150FA-0101JY HPWTEG-300FA-0101JY



【HPWTEG-150FA】

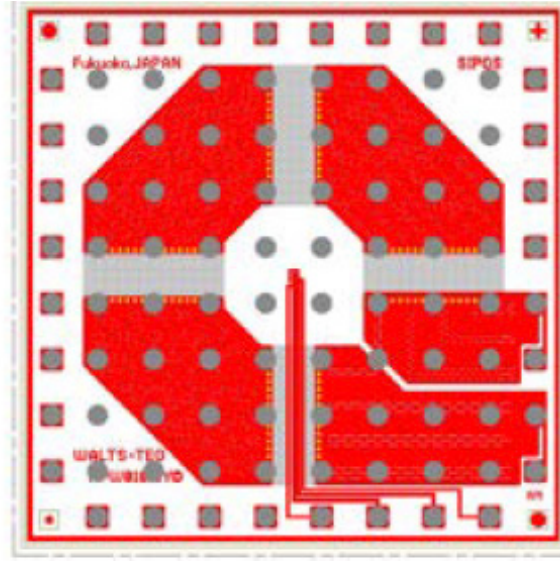

【HPWTEG-300FA】

Specifications	HPWTEG-150FA	HPWTEG-300FA
Base Wafer	HPW-0101JY	HPW-0101JY
Electrode	Ni + SnAg Bump	Cu Pillar Bump
Bump Pitch	150 μ m	300 μ m
Bump Size	ϕ 110 μ m	ϕ 110 μ m
Bump Height	Ni5 μ m+SnAg75 μ m	Cu45 μ m+SnAg10 μ m
Passivation Opening	70 μ m (Octagon)	70 μ m (Octagon)
Polyimide Opening	ϕ 90 μ m	ϕ 90 μ m
Number of Pad	32 pads	32 pads
Number of Bump	32 bumps + 253 Dummy bumps	32 bumps + 64 Dummy bumps
Number of Chip	2964chips/wafer	2964chips/wafer
Option	Back Side Metallization	Back Side Metallization

HPW MarkII-0101JY

(for Thermal Resistance Analysis at High Power)

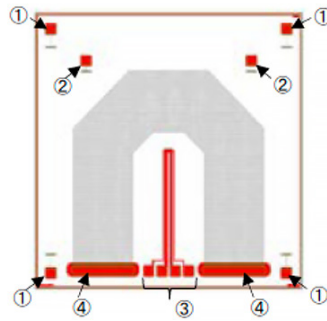
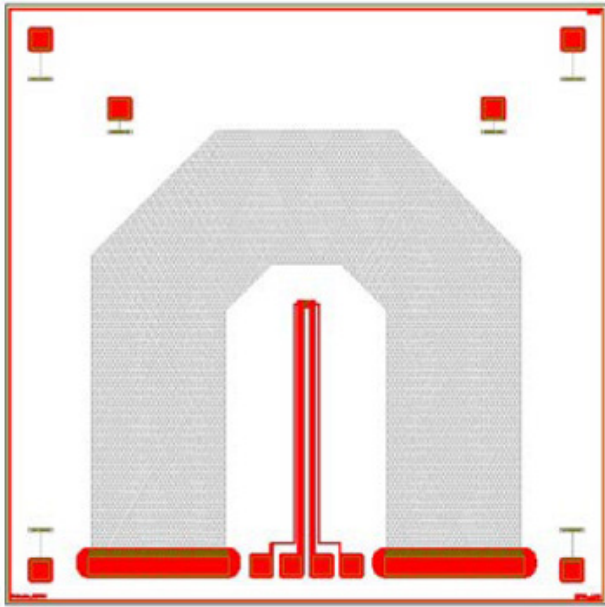

Pad ① : High voltage plate
 Pad ② : High breakdown voltage Diode
 Pad ③ : Temperature measurement diod
 Pad ④ : Heating resistance

Specifications		
Wafer Size	8inch(Notch)	
Wafer Thickness	725±25µm	
Chip Size	10.0mm■	
Pad Size (Passivation opening)	Pad ①~③	0.4mm ■ (0.3mm■)
	Pad ④	2.72mm x 0.5mm (2.32mm x 0.3mm)
Scribe line width	120µm	
Function	Thermal Analysis by Diode Heat Generation by Resistance Insulation Resistance Test by High Voltage Plate	
Electrode Material	Al pad	
Number of Pad	12 pads	
Number of Chip	224 chips/wafer	
Maximum Output	Max.55W/Chip	
Option	Back Side Metallization	

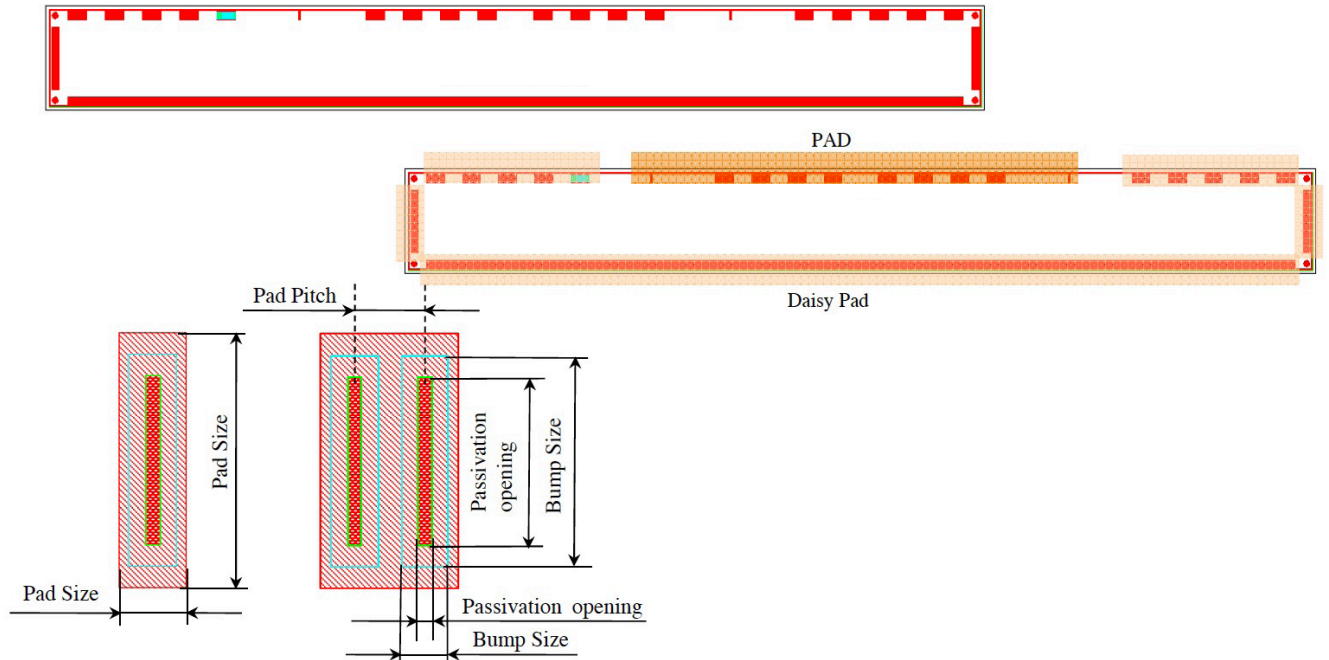

(Daisy Pad)

Specifications	LCD30A
Wafer Size	8 inch
Wafer Thickness	725±25µm
Chip Size	15.1mm×1.6mm
Pad pitch	30µm
Function	Daisy Chain
Pad config	Peripheral
Electrode	Au (Plate)
Pad Size	28µm×120µm
Passivation opening	6µm×80µm
UBM Size	20µm×100µm
Bump Size	20µm×100µm
Scribe width	100µm
Number of Pad	726pads/chip
Number of Chip	1056 chips/wafer

KIT LCD30-0101JY

[for LCD30-0101JY]

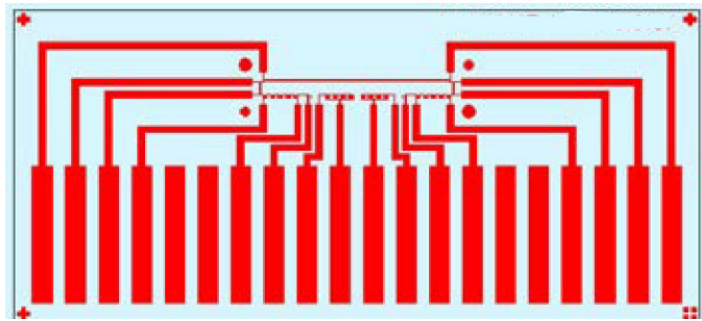

Product Name	KIT LCD30-0101JY
Material	Non Alkali Glass
Outline	52.55mm×24.00mm×0.70mmt
Material of Wire	ITO 1,500A (option IZO)
Function	Daisy Chain Breakdown Voltage Check between the Bumps
Conformed chip	LCD30A-0101JY

KIT COF30-0101JY

[for LCD30-0101JY]

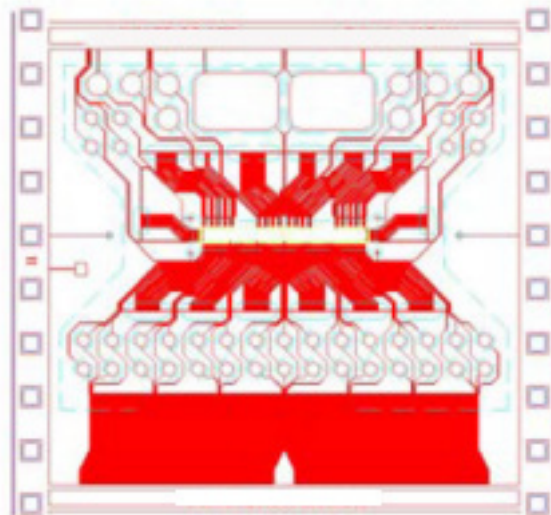

Product Name	KIT COF30-0101JY
State	reel
Product Name	S'PERFLEX
Plating Material	Sn
Conformed chip	LCD30A-0101JY

PWB8-0101JY

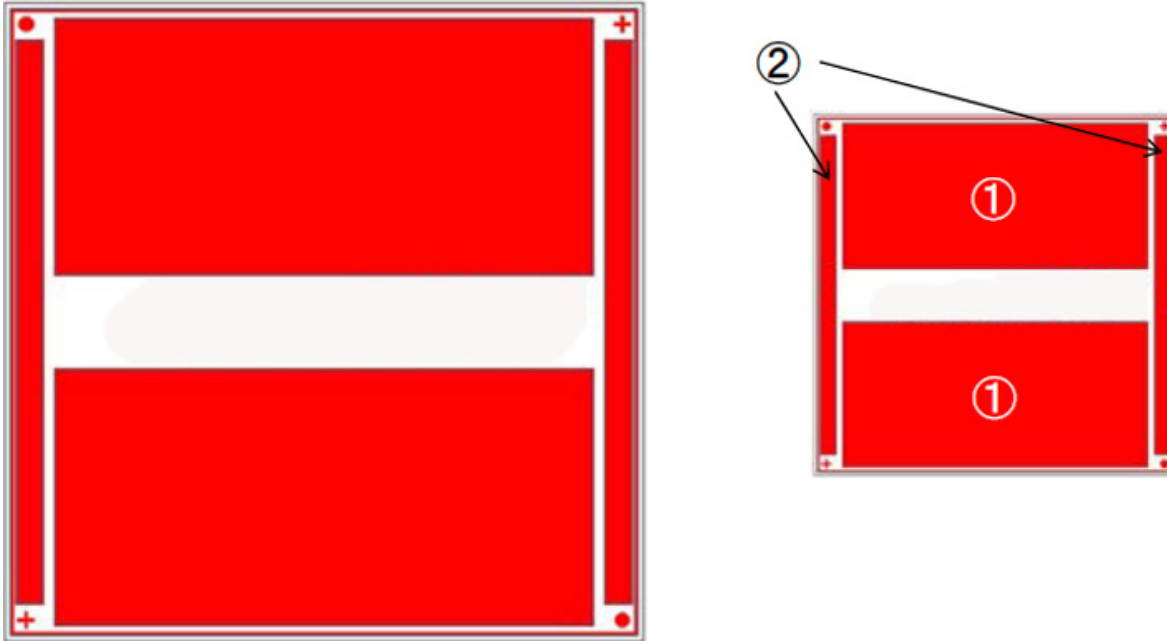

Specifications	TYPE-A	TYPE-B
Wafer Size	8 inch	8 inch
Wafer Thickness	725±25μm	725±25μm
Chip Size	6.0mm■	6.0mm■
Metal Thickness	Al-Si-Cu 4μm	Al-Cu 4μm
Function	Bondability Check	Bondability Check
Pad config	Plane	Plane
Pad Size	① 5060μm × 2420μm	① 5060μm × 2420μm
	② 270μm × 5300μm	② 270μm × 5300μm
Passivation opening	① 5040μm × 2400μm	① 5040μm × 2400μm
	② 250μm × 5280μm	② 250μm × 5280μm
Scribe width	100μm	100μm
Number of Chip	700 chips/wafer	700 chips/wafer

ME (1015, 2025, 3035) (for Migration Test)

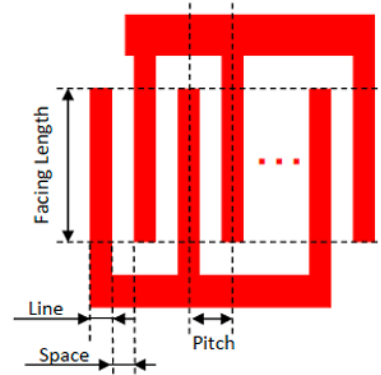
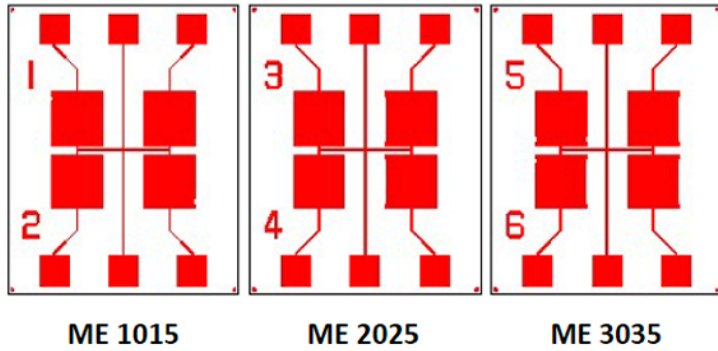

Specifications	ME 1015		ME 2025		ME 3035	
Wafer Size	12 inch		12 inch		12 inch	
Chip Size	20mm×25mm		20mm×25mm		20mm×25mm	
Chip Name	Chip_10_15		Chip_20_25		Chip_30_35	
Metal Height	5.5μm		5.5μm		5.5μm	
Facing Length	3mm		3mm		3mm	
Line/Space	15μm/10μm	15μm/15μm	15μm/20μm	15μm/25μm	15μm/30μm	15μm/35μm
Pitch	25μm	30μm	35μm	40μm	45μm	50μm
Number of Chip	108 chips/wafer		108 chips/wafer		108 chips/wafer	

SIPOS-SI0631

(for Micro Line Evaluation)

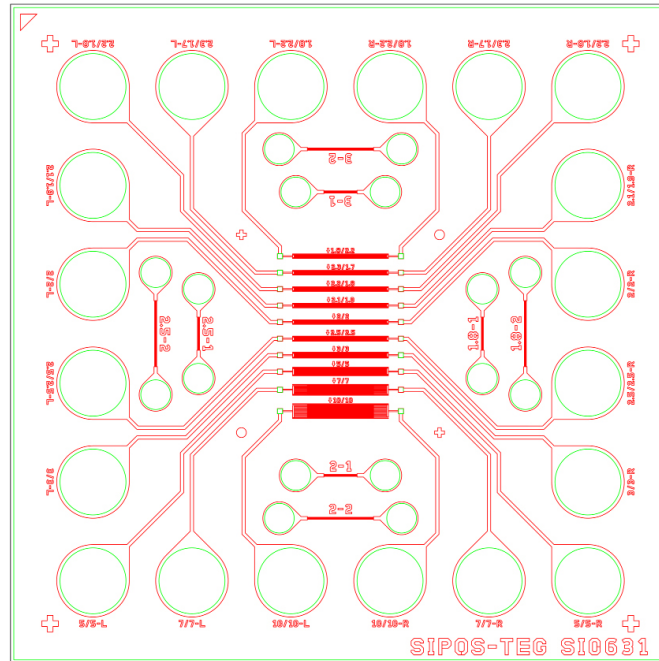

Specifications	SIPOS-SI0631
Wafer size	φ8 inch
Wafer Thickness	725±25um
Chip size	20.0mm■
Layer	Layer1: wiring layer
Metal material	Cu
Cu thickness	3~4μm
Number of pad	56 pads
Pad size	160μm■
Measurement pad size	2.2mm ●
Number of chip	57 chips/wafer

Evaluation Pattern	Comb pattern
	Comb pattern L/S dimension
	① L/S=10.0μm/10.0μm
	② L/S=7.0μm/7.0μm
	③ L/S=5.0μm/5.0μm
	④ L/S=3.0μm/3.0μm
	⑤ L/S=2.5μm/2.5μm
	⑥ L/S=2.0μm/2.0μm
	⑦ L/S=2.1μm/1.9μm
	⑧ L/S=2.2μm/1.8μm
⑨ L/S=2.3μm/1.7μm	
⑩ L/S=1.8μm/2.2μm	
	interdigital pattern length: 2mm
	Wiring pattern for break check
	3.0μm, 2.5μm, 2.0μm, 1.8μm
	(length: 2.0mm, 1.0mm)

Applications:
Chemical migration evaluation
for resins etc. Mainly used
at material manufacturers.

ITO1101- 0100JY

(for Micro Line Evaluation)

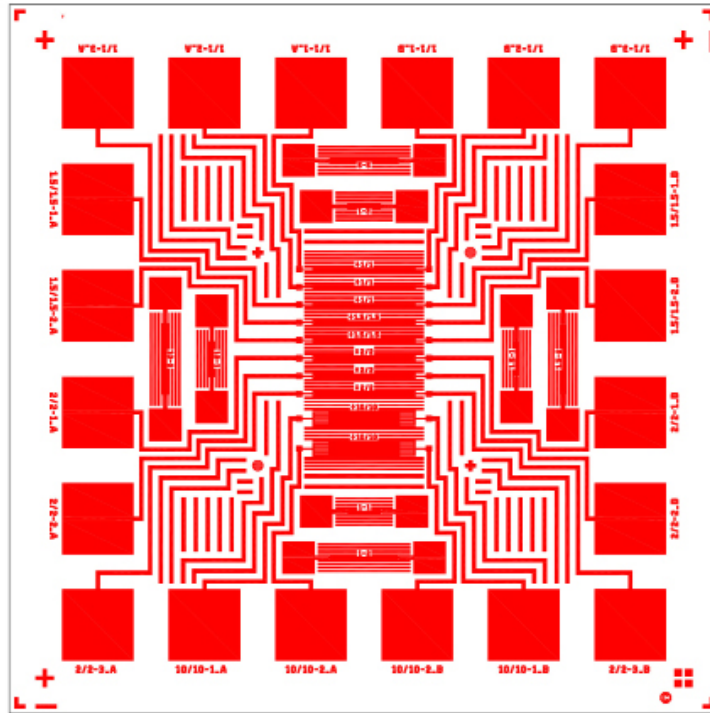

Wafer Size	8 inch
Wafer Thickness	725±25μm
Chip Size	20.0mm
Layer	Layer1: cu wiring
Metal material	Cu
Cu thickness	1.5~2.5μm
Number of pad	56 pads
Pad size	160μm
Measurement pad size	2.0mm/0.9mm
Number of chip	57 chips/wafer
Evaluation Pattern	<ul style="list-style-type: none"> ▪Comb pattern Comb pattern L/S dimension <ul style="list-style-type: none"> ① L/S=1.0μm/1.0μm ② L/S=1.25μm/1.25μm ③ L/S=1.5μm/1.5μm ④ L/S=2.0μm/2.0μm ⑤ L/S=3.0μm/3.0μm *interdigital pattern length : 2mm ▪Wiring pattern for break check <ul style="list-style-type: none"> 2.0μm, 1.5μm, 1.25μm, 1.0μm (length: 2.0mm, 1.0mm)

Applications:
Chemical migration evaluation for resins etc.
Mainly used at material manufacturers.

ITO1102-0100JY (for Micro Line Evaluation)

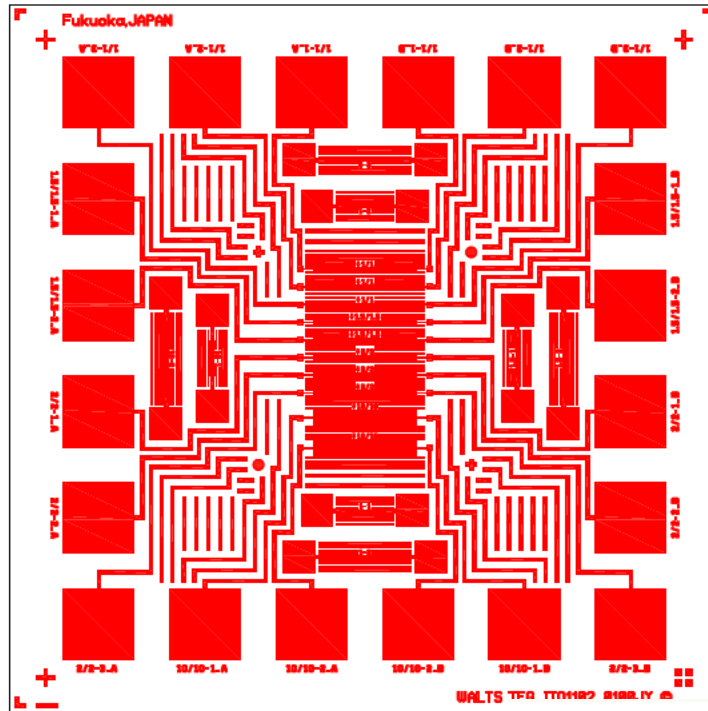

Wafer Size	8 inch
Wafer Thickness	725±25μm
Chip Size	20.0mm
Layer	Layer1: cu wiring
Metal material	Cu
Cu thickness	1.5~2.5μm
Number of pad	56 pads
Pad size	160μm
Measurement pad size	2.0mm/0.9mm
Number of chip	57 chips/wafer
Evaluation Pattern	<p>Comb pattern L/S dimension</p> <p>① L/S=1.0μm/1.0μm</p> <p>② L/S=1.5μm/1.5μm</p> <p>③ L/S=2.0μm/2.0μm</p> <p>④ L/S=10.0μm/10.0μm</p> <p>*interdigital pattern length:2mm</p> <p>•Wiring pattern for break check 10.0μm, 2.0μm, 1.5μm, 1.0μm (length: 2.0mm, 1.0mm)</p>

Applications
Chemical migration evaluation for resins etc.
Mainly used at material manufacturers.

Kit Identifier

Component Part Numbers / Kit Numbers

Component Part Description	Kit Part Description																
	PC000	PC003	PC008	PC009	PC011	PC012	PC013	PC014	PC015-C	PC016-F	PC049	PC052-B	PC2009-B	WTK	SABER	SMTA-H	SMTA-Ultra
008004																	●
01005SMC																●	●
01005SMR	●		●										●		●	●	●
0201SMC																●	●
0201SMR	●		●						●		●		●		●	●	●
0402SMC								●			●	●				●	
0402SMR	●		●					●	●	●	●		●		●	●	
0603SMC								●				●				●	
0603SMR	●	●	●	●				●	●		●		●		●	●	
0805SMC												●					
0805SMR		●	●	●				●	●	●		●			●		
1206SMC									●			●				●	
1206SMR		●	●	●				●	●	●		●			●	●	
1206SMR-MELF								●									
1210SMR															●		
1/2-WATT				●			●										
1/4-WATT				●			●	●	●	●							
6032SMTA				●													
Axial Electrolytic, 5x11				●			●										
CK05 (Spacer)				●			●	●	●								
Conn-SMT-2x16												●	●				
Conn-TH-Ver-4x24												●					
DO35				●			●	●	●								
DKPAK-(TO252)								●	●						●		
DIP14		●											●				
DIP16			●				●	●	●	●			●				
DIP20								●	●		●						
A-CABGA36-.8mm-6mm-DC				●									●				
A-CABGA100-.8mm-10mm-DC													●				
A-CABGA196-1.0mm-15mm-DC					●								●				
A-CABGA208-.8mm-15mm-DC										●							
A-CABGA256-1.0mm-17mm-ISO											●						
A-CTBGA84-.5mm-7mm-DC					●												
A-CTBGA228-.5mm-12mm-DC					●								●		●	●	
A-CVBGA97-.4mm-5mm-DC			●										●				
A-CVBGA360-.4mm-10mm-DC					●								●				
A-CVBGA368-.3mm-8mm-DC															●	●	
A-CVBGA432-.4mm-13mm-DC					●											●	
A-PBGA208-1.27mm-23mm-DC						●											
A-PBGA256-1.0mm-17mm-DC			●							●			●				
A-PBGA256-1.27mm-27mm-DC				●		●											
A-PBGA304-1.27mm-31mm-DC						●											
A-PBGA388-1.27mm-35mm-DC			●			●							●				

Kit Identifier

Component Part Numbers / Kit Numbers

Kit Part Description																	
Component Part Description	PC000	PC003	PC008	PC009	PC011	PC012	PC013	PC014	PC015-C	PC016-F	PC049	PC052-B	PC2009-B	WTK	SABER	SMTA-H	SMTA-Ultra
008004SMC																	●
01005SMC																●	●
01005SMR	●		●										●		●	●	●
0201SMC																●	●
0201SMR	●		●						●		●		●		●	●	●
0402SMC								●				●				●	
0402SMR	●		●					●	●	●	●		●		●	●	
0603SMC								●				●				●	
0603SMR	●	●	●	●				●	●		●		●		●	●	
0805SMC												●					
0805SMR		●	●	●					●	●	●		●		●		
1206SMC										●		●				●	
1206SMR		●	●	●					●	●	●		●		●	●	
1206SMR-MELF									●								
1210SMR															●		
1/2-WATT				●			●										
1/4-WATT				●			●		●	●	●						
6032SMTA				●													
Axial Electrolytic, 5x11				●			●										
CK05 (Spacer)				●			●		●	●							
Conn-SMT-2x16												●	●				
Conn-TH-Ver-4x24												●					
DO35				●			●		●	●							
DPAK-(TO252)									●	●					●		
DIP14		●											●				
DIP16				●			●		●	●	●						
DIP20											●						
A-CABGA36-.8mm-6mm-DC				●									●				
A-CABGA100-.8mm-10mm-DC													●				
A-CABGA196-1.0mm-15mm-DC					●								●				
A-CABGA208-.8mm-15mm-DC											●						
A-CABGA256-1.0mm-17mm-ISO												●					
A-CTBGA84-.5mm-7mm-DC					●												
A-CTBGA228-.5mm-12mm-DC					●								●			●	●
A-CVBGA97-.4mm-5mm-DC			●										●				
A-CVBGA360-.4mm-10mm-DC					●								●				
A-CVBGA368-.3mm-8mm-DC																●	●
A-CVBGA432-.4mm-13mm-DC					●												●
A-PBGA208-1.27mm-23mm-DC						●											
A-PBGA256-1.0mm-17mm-DC			●								●		●				
A-PBGA256-1.27mm-27mm-DC				●		●											
A-PBGA304-1.27mm-31mm-DC						●											
A-PBGA388-1.27mm-35mm-DC			●			●							●				

Conformal Coating Process Flow Chart



Dummy Components And PCB Test Boards For Cleanliness And Conformal Coating Process Testing

Practical Components provides products and services for the testing and evaluation of Conformal Coating materials on assembled PCB test boards. Conformal coating has provided many benefits to high and

reliability industries as well as commercial off the shelf products being used in extreme environments. Changes in technology have caused conformal coating to become more prevalent in different industries like telecommunications, automotive, and other hand held devices. All these products have benefited from the use of coatings for environmental protection and product enhancements.

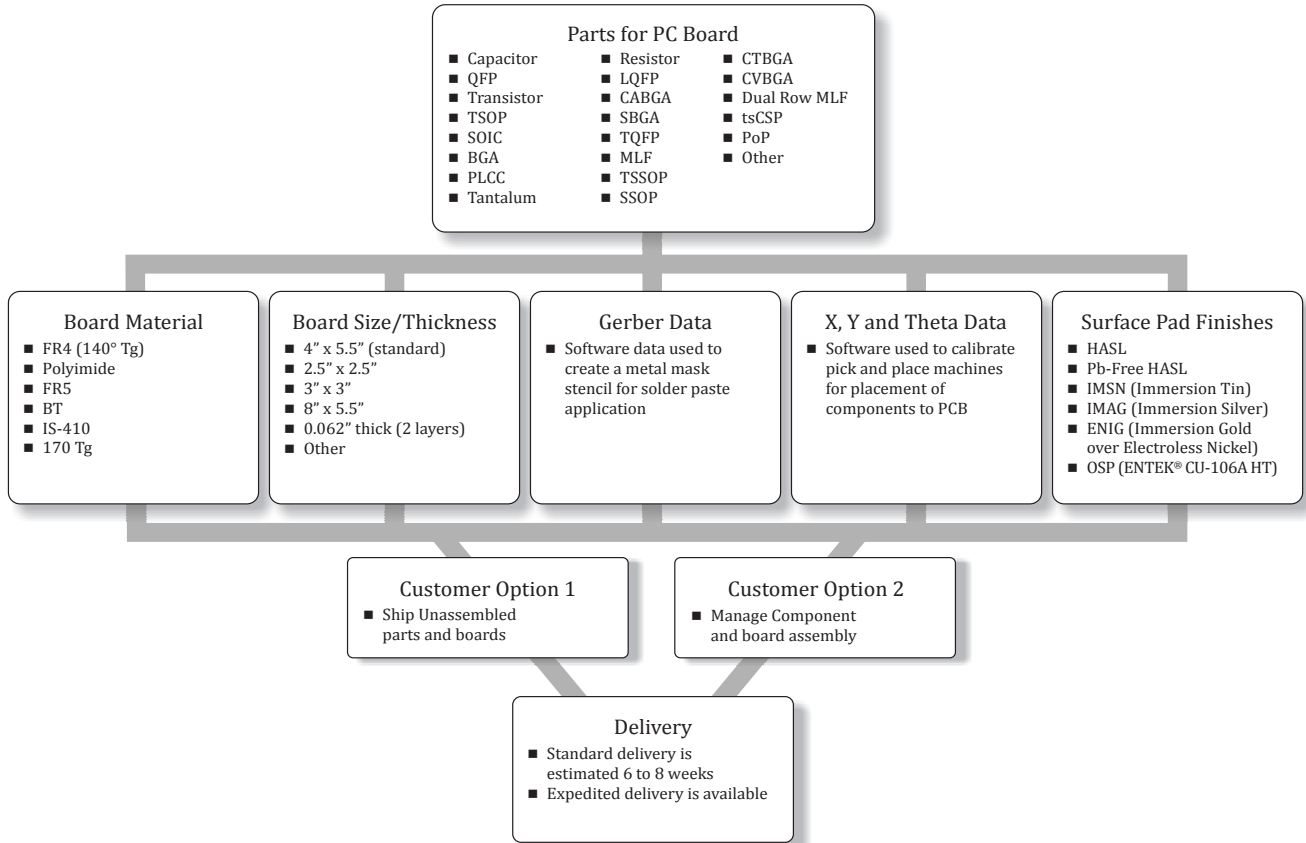

Practical Components products can be effective in the following areas:

- Is conformal coating necessary?
- Clean or no clean
- SIR testing
- Coating process options
- Coating reliability
- Coating material evaluation
- Correct design for costing application
- Masking options
- Inspection and quality control of coating
- Repair and rework of PCB assemblies

The products and services provided by Practical Components in support of the evaluation items listed above are:

- Dummy Components including IC, Passives, transistors, connections or special items as requested
- Test PCB dummy boards, made to any size, thickness, material, or special requirements as requested
- Assembly of dummy components to the test PCB boards
- Design of the PCB board to customer's exact specifications
- Management of the procurement process and supply chain

All Practical Components products are fully guaranteed. Our products are made to the exact equivalent of live components, without the internal live die or electrically functioning board. This significantly lowers the cost of the components and test boards. Practical Components can be one stop shop from board design and layout to completed assemblies ready for coating. You can be focused on the coating not the logistical chain of acquiring testing assemblies.

Test Boards for Cleanliness and Conformal Coating

Practical Components offers the following PCB Test boards for printed wiring assemblies materials for process qualification evaluations.

Practical Components Test Coupon Board Availability		Cu	HASL	ImAg	ENIG
PCB052/Rev B	CRET board	X	X	X	X
PCB-B-24	Standard Test Board	X	X	X	X
PCB-B-25A	Standard Test Board	X	X	X	X
PCB-B-36	Standard Test Assembly	X	X	X	X
PCB-SIR	Test Board	X	X	X	X
PCB-Saber	Evaluation Test Board	X	X	X	X
PCB015	Rework Test Board		X		X

PCB052 CRET Board

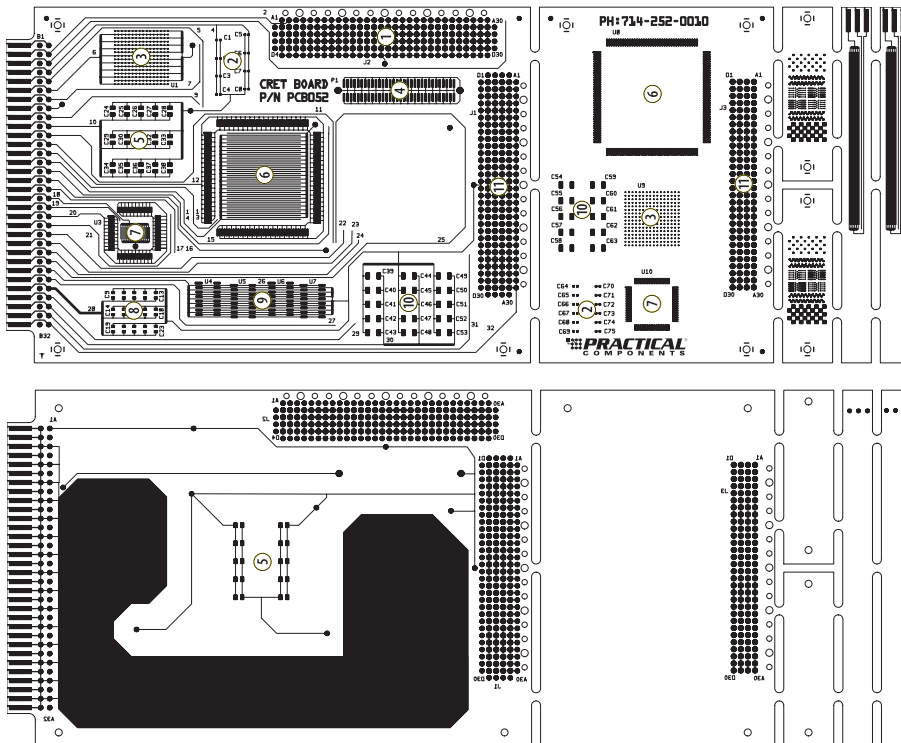

The Practical Components B-52 CRET (Cleanliness & Residue Evaluation Test) board is designed to help determine the ionic cleanliness of a customer's manufacturing process. The test board follows guidelines associated with the IPC-B-52 Test Vehicle. There are several different ways to measure residues and their effects on electrical performances, the two most common in the industry are ionic cleanliness testing, for determination of ionic residues, and surface insulation resistance (SIR) testing, for the evaluation of electrochemical failures in humid environments.

Of the various methods for determination of ionic residues, the method of choice is ion chromatography, which determines both the type of ionic residue and the amount of the residue. The IPC method for ion chromatography is IPC-TM-650, method 2.3.28. For SIR testing, the most modern test method, involving frequent or continuous monitoring, is IPC-TM-650, method 2.6.3.7. Consequently, a test vehicle was needed which could be used for both ion chromatography and surface insulation resistance testing, but which was more representative of mainstream manufacturing materials and process.

Test Boards for Cleanliness and Conformal Coating

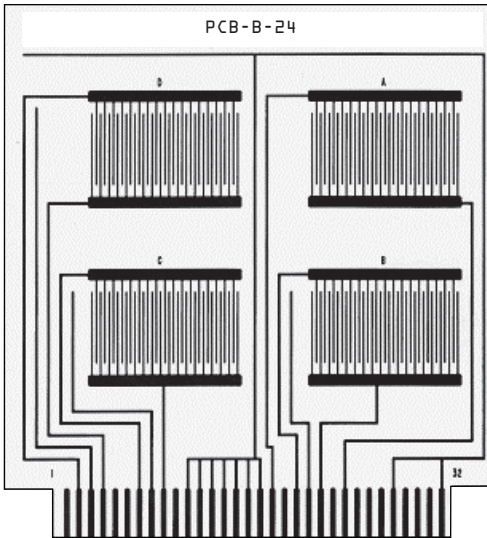

PCB-B-24 Standard Test Board

The PCB-B-24 standard test board is compliant with the IPC Phase 3 cleaning and cleanliness test program. It was designed to be a vehicle for examining the interactions between laminate, surface metalizations, and fluxes. It is the primary qualification vehicle for ANSI J-STD-004, which is the IPC specification on fluxes.

The four comb patterns are identical and have 16 mil lines and 20 mil space. These values were chosen both for ease of stencil printing solder paste, and the board can be wave soldered with minimal chance of solder bridging.

The PCB-B-24 test board is an excellent vehicle for narrowing down fluxes or solder material, or testing material interaction.

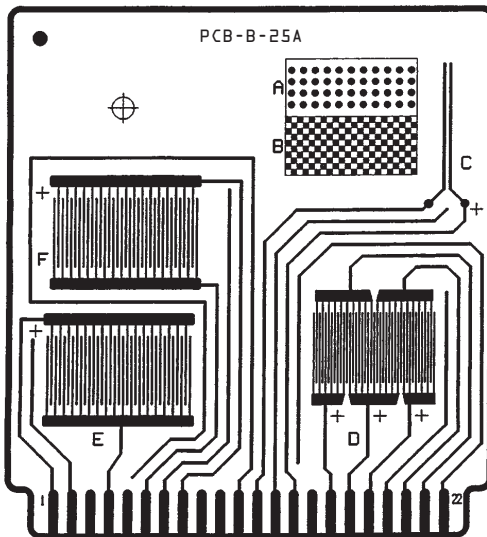

PCB-B-25A Standard Test Board

The PCB-B-25A test board meets the current guidelines for solder Masks (IPC-SM-804C) and conformal coatings (IPC-CC-830A).

The board is normally 0.062" FR-4. The board is simple print-and-etch. The surface is bare copper for materials qualification, but could be any Surface finish required.

The PCB-B-25A is used to evaluate interactions between solder masks, solder paste, and fluxes.

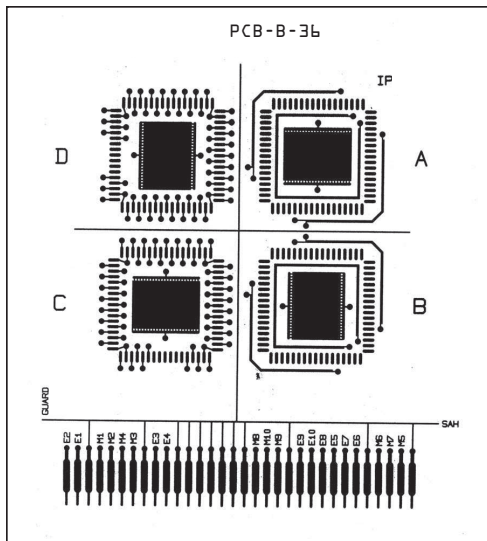

PCB-B-36 Standard Test Assembly

The PCB-B-36 standard test board was designed for the IPC cleaning cleanliness test program, Phase 1. It was designed for examining the ability of a cleaning solvent to remove flux residues, and to examine the effects of entrapped residues under low standoff components. The PCB-B-36 test board can be used as a process qualification vehicle for the J-STD-001. This board has 10 SIR test patterns. Two patterns #2 and #4 are mounting pads in quadrants C and D. The pad spacing is 25 mils for patterns #2 and #4. The contact fingers of the board are normally gold plated for compatibility with edge card connectors. The remaining metallization is normally bare copper, or any surface finish. In most cases, four leadless ceramic chip carriers (LCCs) are mounted on the board, one in each quadrant.

This test vehicle is designed to test combinations of conformal coatings, fluxes, solder paste and their interactions with each other. Testing cleaning residue under low stand off components is a benefit of the PCB-B-36 test board.

Test Boards for Cleanliness and Conformal Coating

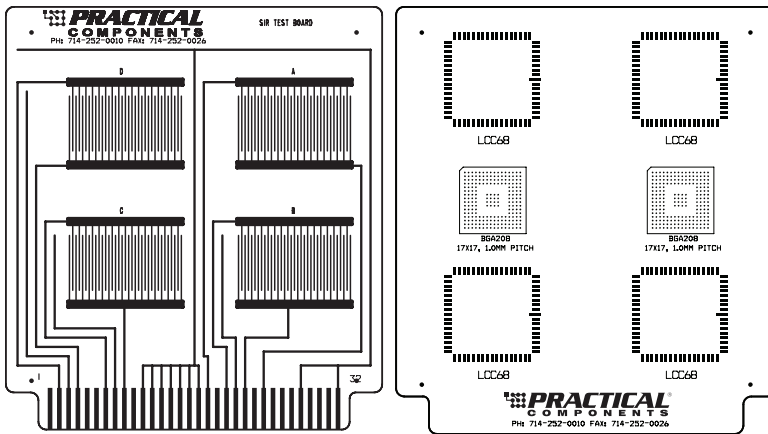

Practical Components SIR Test Board

The Practical Components SIR board is a double sided board to characterize fluxes by determining the degradation of electrical insulation resistance of rigid printed wiring board specimens after exposure to the specified flux. The board contains pads for LCC68 and A-PBGA208-1.0mm-17mm components. Boards and kits are available in Tin-Lead or Lead-Free.

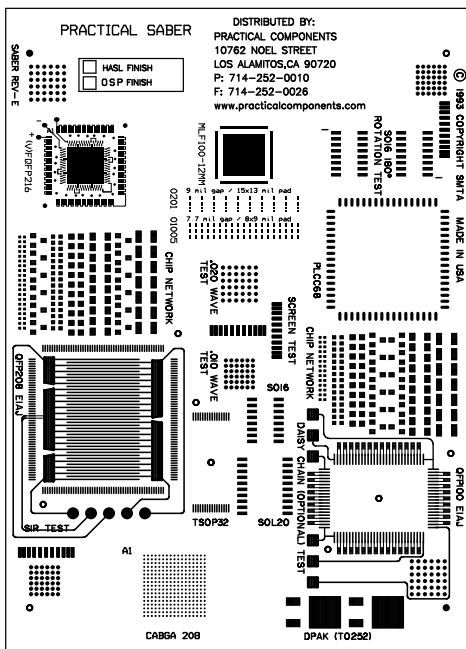

Practical Components Saber Board

The SABER evaluation board can be used to evaluate pick and place equipment, reflow process, component, cleanliness and solder paste screening. The SABER board also has honeycomb patterns for SIR testing. Board finishes include ImAg, ENIG and Pb-Free HASL. Standard board material is IS-410.

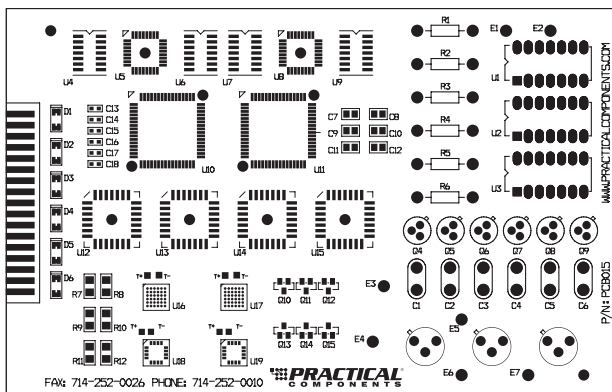

Practical Components PC015 Assembled Test Board

Available Pre-Assembled, this board is the ideal vehicle for Off the shelf Conformal Coating testing. Pre-Populated with a variety of component types, from LQFPs and CABGAs, DIPs down to 0603 chips this board offers a real-world conformal coating testing surface and gives standardized and repeatable results. The PC015 is available in Tin-Lead or Lead-Free versions. The PC015 and components can also be delivered unassembled or partially assembled, example: only the surface mount components mounted on the board. Practical Components also specializes in designing PCB test boards made to size, thickness, material or specified requirements as requested. Practical can also manage the procurement process and supply chain, including assembly and application of materials. Practicals PC015 Rework Kit conforms to IPC 7711/7721 standards or reworking.

SIR Test Board and Kit

REVISED [Rev. A]

The Practical SIR board is double sided board to characterize fluxes by determining the degradation of electrical insulation resistance of rigid printed wiring board specimens after exposure to the specified flux. This test is carried out at height humidity and heat conditions. The board contains pads for LCC68 and A-PBGA208-1.0mm-17mm components. Kit is available Tin-Lead or Lead-Free.

SIR Test Board

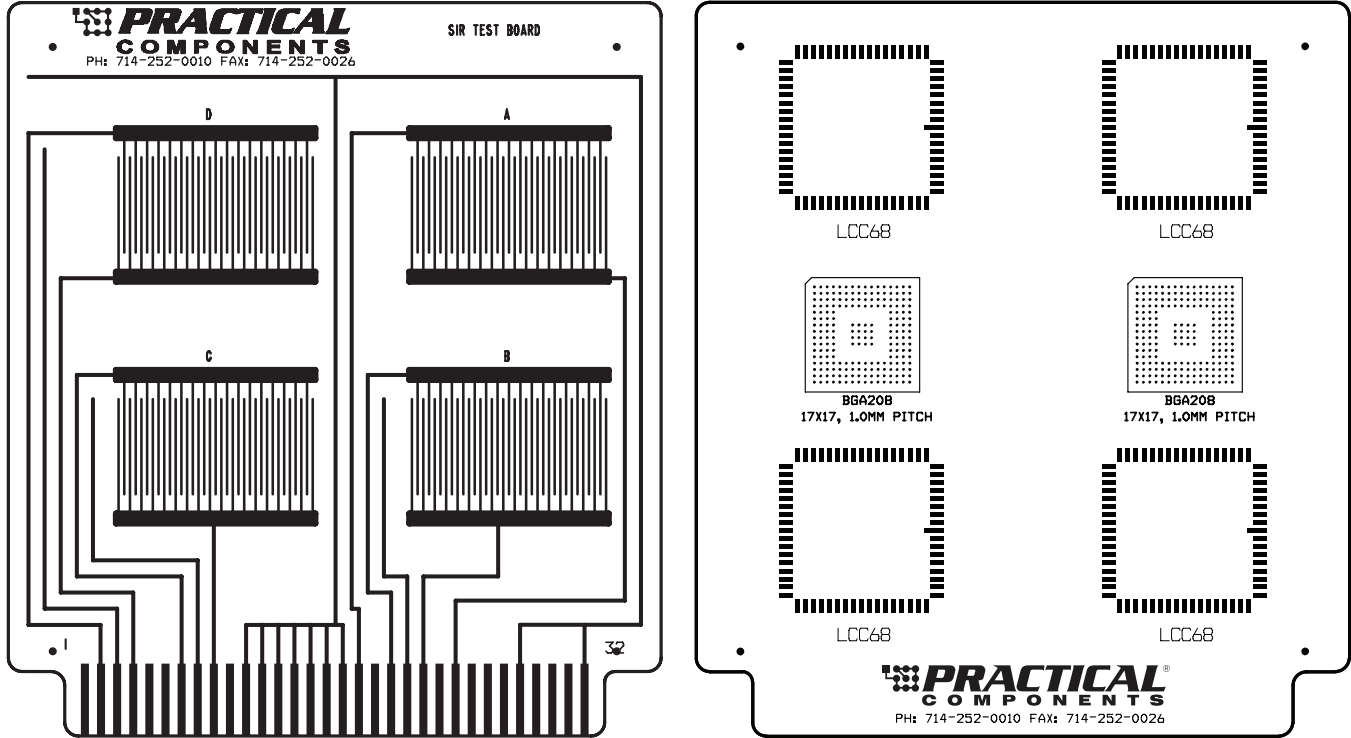

SIR Kits

Part Description	Quantity Per 1 Kit	Quantity Per 5 Kits	Quantity Per 10 Kits
68LCC-1.27mm-24.1mm	4	20	40
A-PBGA208-1.0mm-17mm-DC	2	10	20
Kit Order Number: (Tin-Lead)	SIR-0-01	SIR-0-05	SIR-0-10
Kit Order Number: (Lead-Free)	SIR-0-01-LF	SIR-0-05-LF	SIR-0-10-LF

Notes

- Gerber and X, Y Theta data included at no charge.
- PBGA is available Lead-Free with SAC305 or SAC405 solder ball alloy's. LCC is only available with Au castellations which is standard.
- Board finishes available are:
Immersion Silver, ENIG, Bare Copper and HASL.



SMTA Saber Evaluation Board and Kit

REVISED [Rev. E]

The SMTA Saber Evaluation Kit.

Practical Components is licensed by SMTA to distribute the Saber Evaluation PC Board. The Saber Board includes land patterns for a wide variety of JEDEC and EIAJ components.

The Saber Board is used to evaluate:

- P&P equipment
- Reflow process
- Component placement accuracy
- Cleanliness
- Speed and accuracy of component placement
- Solder paste screening

Notes

- Gerber Data and X, Y Theta Data are available if required at no charge.
- Digitized files provided by Aegis Software included at no charge.
- Lead-free parts are available.
- Board finishes available are:
Immersion Silver, ENIG, Bare Copper, OSP and HASL.



Available as a

Single Pack Kit

SMTA Saber Evaluation PC Board

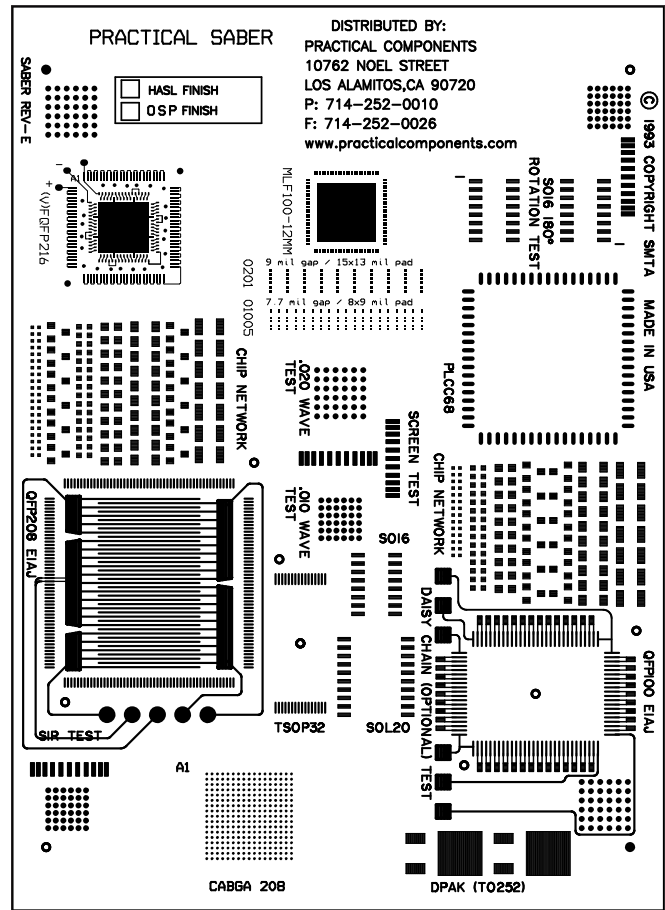

Double Sided (top view)
Board size: 3.875" x 5.375", .062" thick.

Part Description	Quantity Per 1 Kit	Quantity Per 24 Kit	Quantity Per 48 Kits	Quantity Per 96 Kits
PCB-Saber	1	24	48	96
01005SMR-Sn	57	1,368	2,736	2,736
0201SMR-Sn	30	720	1,440	2,880
0402SMR-Sn	34	1,000	1,632	4,000
0603SMR-Sn	31	1,000	1,488	3,000
0805SMR-Sn	21	500	1,008	2,000
1206SMR-Sn	20	500	960	2,000
1210SMR-Sn	14	500	672	2,000
SOT23-Sn	24	1,000	1,152	3,000
A-CABGA208-.8mm-15mm-DC-305	1	24	48	96
DPAK(TO252)-Sn	2	48	96	200
SO16GT-3.8mm-Sn	3	100	144	288
SO20GT-7.6mm-Sn	1	24	48	96
A-MLF100-12mm-.4mm-DC-Sn	1	24	48	96
PLCC68-Sn	1	24	48	96
T1-TSOP32-8x18.4mm-.5mm-Sn	1	24	48	96
QFP208-28mm-.5mm-2.6mm-Sn	1	24	48	96
QFP100-140x20mm-.65mm-3.9-DC-Sn	1	24	48	96
Kit Order Number: (Tin-Lead)	SMTA-Saber-1	SMTA-Saber-24	SMTA-Saber-48	SMTA-Saber-96
Kit Order Number: (Lead-Free)	SMTA-Saber-1-LF	SMTA-Saber-24-LF	SMTA-Saber-48-LF	SMTA-Saber-96-LF

B-52 CRET Rev B

Cleanliness & Residue Evaluation Test Kits



The Practical Components B-52 CRET (Cleanliness & Residue Evaluation Test) Kit is designed to help determine the ionic cleanliness of a customer's manufacturing process. The test boards and components follow guidelines associated with the IPC-B-52 Test Vehicle.

There are several different ways to measure residues and their effects on electrical performances, the two most common in the industry are ionic cleanliness testing, for determination of ionic residues, and surface insulation resistance (SIR) testing, for the evaluation of electrochemical failures in humid environments.

Of the various methods for determination of ionic residues, the method of choice is ion chromatography, which determines both the type of ionic residue and the amount of the residue. The IPC method for ion chromatography is IPC-TM-650, method 2.3.28.

For SIR testing, the most modern test method, involving frequent of continuous monitoring, is IPC-TM-650, method 2.6.3.7. Consequently, a test vehicle was needed which could be used for both ion chromatography and surface insulation resistance testing, but which was more representative of mainstream manufacturing materials and processes. The IPC-B-52 Test Vehicle was the result.

The Practical B-52 CRET test vehicle is divided into four primary segments:

1. The main SIR test board
2. The Ion Chromatography (IC) test coupon
3. The solder mask adhesion coupons
4. The SIR mini-coupons

On the Rev. B the copper designators have been moved out. The Rev. B board width has increased and the manufacturing rails have been

removed. The non-plated holes were revised to accommodate the alignment pins of the connectors, in addition the diameter of through holes were reduced for better solder ability of the through hole connectors. The ground plane was changed from solid copper to copper mesh.

These changes should have a positive effect both on assembly and evaluation results. Items to note are the B-52 Rev. B is available with just the SIR coupon.

Information regarding this option is available by calling Practical Components at 714-252-0010. In addition, it is recommended that customers use test boards from their current or potential board supplier. Test boards can also be customized to the customers specific needs.

B-52 CRET Rev B Kit

Figure ID	Location	Part Description	Quantity Per Board
3	U1, U9	A-CABGA256-1.0mm-17mm-ISO	2
6	U2, U8	A-QFP160-28mm-.65mm-ISO	2
7	U3, U10	A-TQFP80-12mm-.5mm-ISO	2
9	U4-U7	A-SO16GT-3.8mm-ISO	4
2	C1-C8, C64-C75	0402SMC-10.0pf	20
8	C9-C23	0603SMC-10.0pf	15
5	C24-C38, C76-C85	0805SMC-10.0pf	25
10	C39-C63	1206SMC-10.0pf	25
11	J1, J2, J3	Conn-TH-Ver-4x24-AMP	3
4	P1	Conn-SMT-2x16-Molex	1

Lead-Free Part Number List

Part Number	Part Description
19959	A-CABGA256-1.0mm-17mm-ISO-SAC305
19960	A-QFP160-28mm-.65mm-2.6mm-ISO-Sn
19961	A-TQFP80-12mm-.5mm-2.0mm-ISO-Sn
19962	A-SO16GT-3.8mm-ISO-Sn
20009	0402SMC-10.0pf-Sn
20010	0603SMC-10.0pf-Sn
20011	0805SMC-10.0pf-Sn
20012	1206SMC-10.0pf-Sn
19943	Conn-TH-Ver-4x24-AMP
19944	Conn-SMT-2x16-Molex

Tin-Lead Part Number List

Part Number	Part Description
19967	A-CABGA256-1.0mm-17mm-ISO
19968	A-QFP160-28mm-.65mm-2.6mm-ISO
19969	A-TQFP80-12mm-.5mm-2.0mm-ISO
19970	A-SO16GT-3.8mm-ISO
20005	0402SMC-10.0pf
20006	0603SMC-10.0pf
20007	0805SMC-10.0pf
20008	1206SMC-10.0pf
19943	Conn-TH-Ver-4x24-AMP
19944	Conn-SMT-2x16-Molex

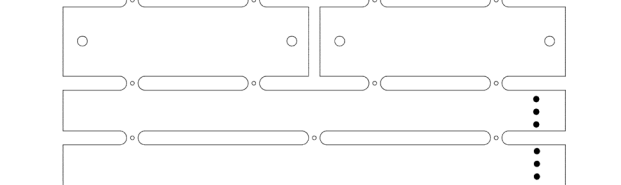
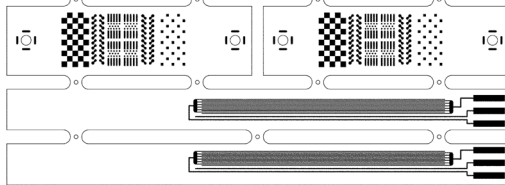
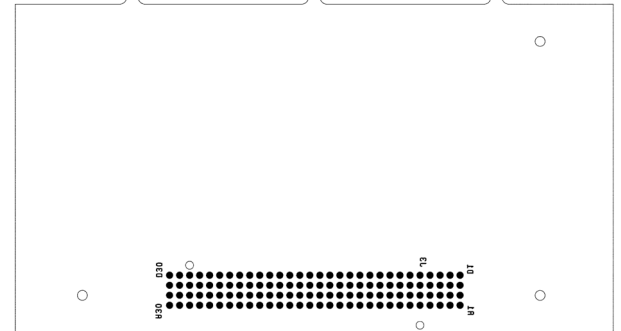
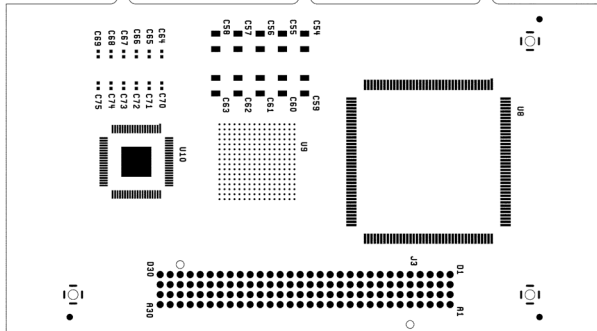
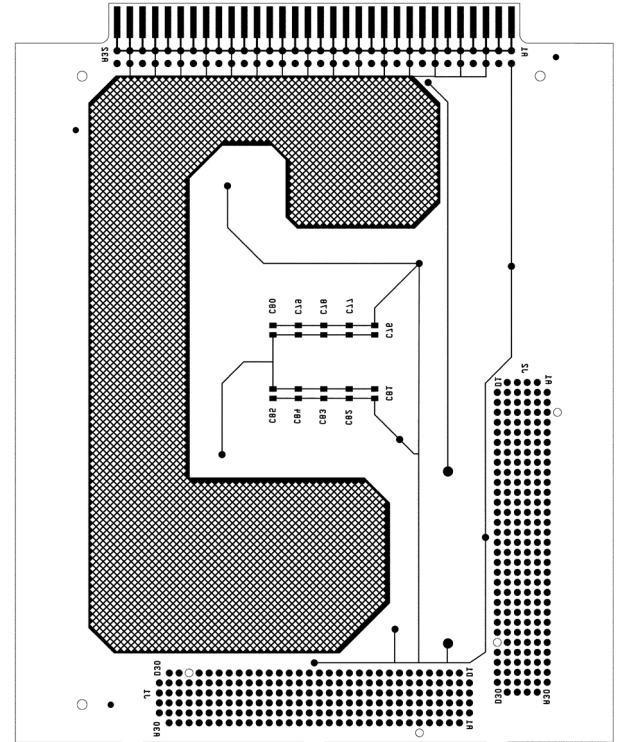
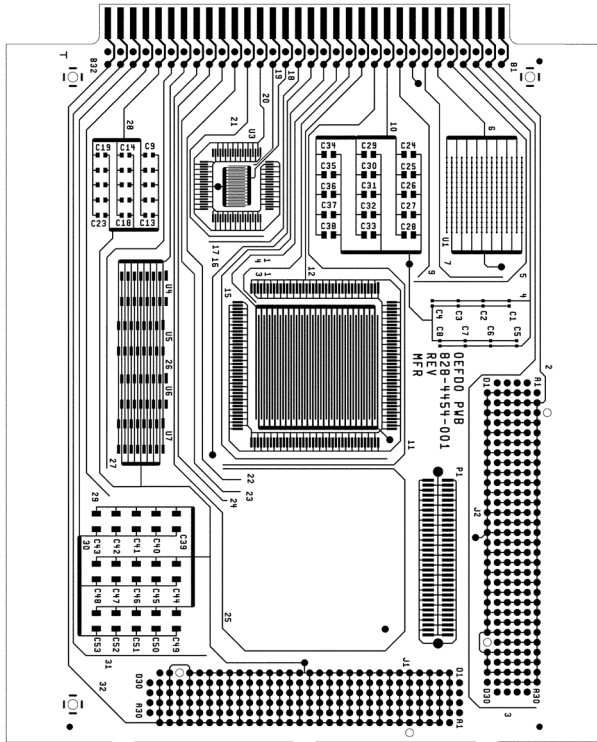

Board size: 4.7" x 10.04", .062" thick.

Notes

- Board finishes available are:
Immersion Silver, ENIG, Bare Copper, OSP and HASL

Ordering Information

- Board Order Number: PCB052-RevB

SMTA-UltraHDI Miniaturized Test Board



Introducing the Ultra HDI Miniaturized Test Vehicle designed to test and develop DFMA guidelines guidelines for the next level of electronics miniaturization.

The migration of circuitry to Ultra HDI brings many benefits in terms of miniaturization. The fabrication technology is undergoing a step-function change in densities – and therefore functionalities – that will enable an entire new generation of electronics for defense, healthcare, transportation and communications.

The fact that a printed circuit board can be fabricated does not necessarily indicate that it can also be assembled. For high-performance products, very little reliability data exists for high reliability UHDI assemblies.

The newly released SMTA Ultra HDI Assembly Test Board brings special attention in terms of validating new processes needed with this miniaturization and testing the reliability of their outputs.

The fact that a printed circuit board can be fabricated does not necessarily indicate that it can also be assembled. For high-performance products, very little reliability data exists for high reliability UHDI assemblies.

The newly released SMTA Ultra HDI Assembly Test Board brings special attention in terms of validating new processes needed with this miniaturization and testing the reliability of their outputs.

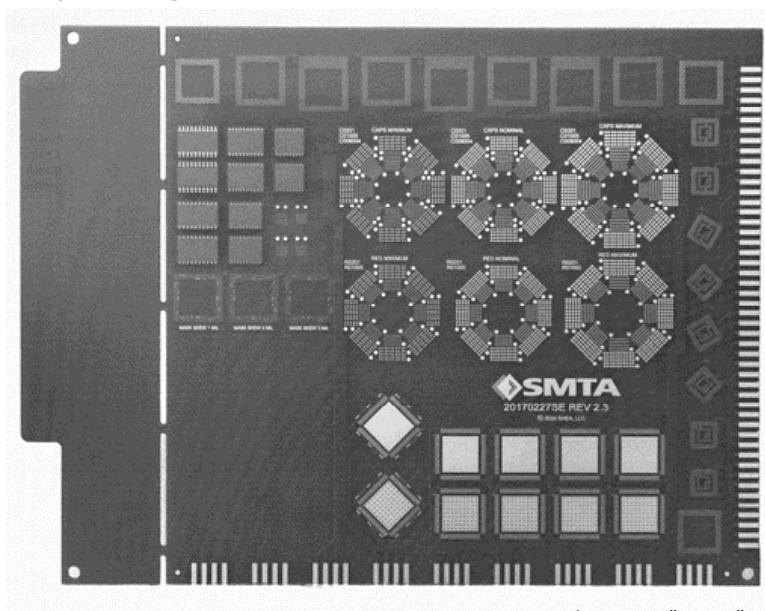

SMTA-Ultra HDI Kit

Board Size: 7.25" x 5.50", .062" thick

Part Description	Quantity Per Kit
PCB-SMTA-UltraHDI	1
CVBGA368-.3mm-8mm-DC	8
CVBGA432-.4mm-13mm-DC	10
CTBGA228-.5mm-12mm-DC	3
MLF100-12mm-.4mm-DC	10
WLP100-.35mm-3.5mm-DC	4
0201SMR	600
0201SMC	664
01005SMR	600
01005SMC	664
008004SMC	640
Zener Diode	20
Zener Diode	20

Notes

- Board finishes available are: Immersion Silver, ENIG, and OSP.
- Gerber Data and X, Y Theta Data are available at no charge.



New test features for printing and reflow challenges include:

• Tombstone Alley

Unequal thermals on chip capacitors (where one pad melts before the other) the molten solder pulls the cap up on its end, and it resembles a tombstone.

Added simple metal-defined pads on one side and mask defined over a ground flood on the other side.

In order to test the dependence of tombstoning on thermal differentials, replicated that design with proper thermal relief and will compare results.

• Skews the Placement

Bottom terminated miniaturized diodes are susceptible to an effect similar to tombstoning. But because they only have solder pads on the bottom, instead of tombstoning, they skew.

• Wee Little Pads (WLP)

• “Schake” it Up

Simulates real-life paste printing situation.

Mixes mask and metal definition and different pad sizes within the same BGA.

Adds solder mask misregistration.

• The Leading Edge Effect

Offsets and dummy pads will help quantify and address the Leading Edge Effect.

• Flower Power

Adds more padstacks and off-axis placement to the original design.

Has test points to check continuity.

• Tumbling Dice

These are carryovers from previous version.

0.3mm pitch BGAs that have mask-defined pads and are oriented at 0, 30, 45 and 60 degrees.

Potential for placement errors and escapes from AOI.

Inner array does not solder as well as outer arrays (thermal deltas).

• BTC Hades & Rework Requirements

Bottom Terminated Components is synonymous with biggest technical challenge.

Very tightly packed and added thermal vias on half of them.

Two of the BTC's are oriented at 45 degrees with 0201 caps inside the typical keepout zone.

Rework reality check: designers need decoupling caps as close to the IC as possible, but it makes rework a real challenge for assemblers.

Four different keepout zones are tested.

Foresite Umpire Test Board



This vehicle is best used to look at process qualifications for the primary and secondary steps. Wave Solder, SMT, Cleaning, and then the secondary steps of temporary solder mask, rework flux, and rework cleaning. It also works well to look at interactions of solder mask with fluxes and/or solder pastes, or materials characterization tests in general. This board is a good selection if you are trying to do correlations between different specifications, e.g. IPC and Bellcore. The two B-24 comb patterns allow you to do SIR for both Bellcore and J-STD-004. Pattern D can be used to correlate to existing B-25 data, or for Bellcore electromigration testing. The military Y pattern can be used for many military qualification tests. Then a direct comparison between the military Y pattern and the C3 localized test system can be made.

The Umpire test board is a current qualification vehicle for processes (IPC-ANSI-J-STD-001) and conformal coatings (IPC-CC-830A).

Advantages

- A good vehicle to use for full process evaluations
- Easy to manufacture and therefore inexpensive
- Has all the common patterns used for SIR and electromigration resistance testing plus the component SIR patterns such as the 80 pin TQFP, 256 BGA.
- Can correlate to B-24, B-25A and B36 test boards.
- Is recognized as a valid test vehicle for Bellcore testing (both TR-78 & GR-79)
- Relatively easy to wire and test
- Can do adhesion testing and dielectric strength tests
- Good vehicle for solder mask interactions and effects

Disadvantages

- None

PC051 Umpire Kit

Part Description	Quantity per Kit
PCB051-Foresite	1
PDIP14-Socket	40
68LCC-1.27mm-24.11mm-TR	20
WM2723-ND-TR	10
S1221E-16-ND-TR	10
A-TQFP80-12mm-.5mm-2.0-TR	10
A-PBGA256-1.27mm-27mm-DC-TR	10
A-MLF40-6mm-.5mm	90
Kit Order Number: (Tin-Lead)	PC051-10
Kit Order Number: (Lead-Free)	PC051-10-LF

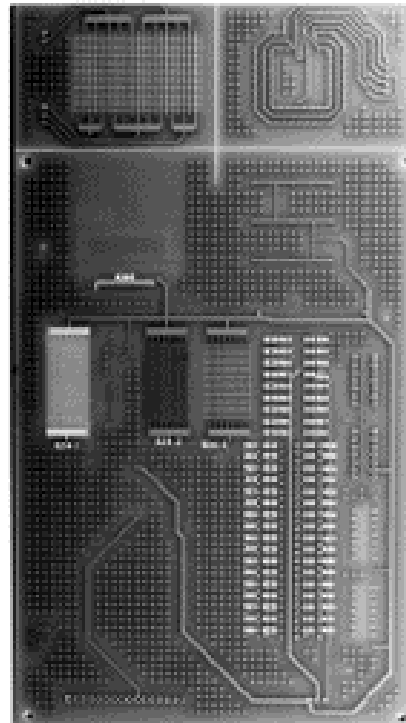
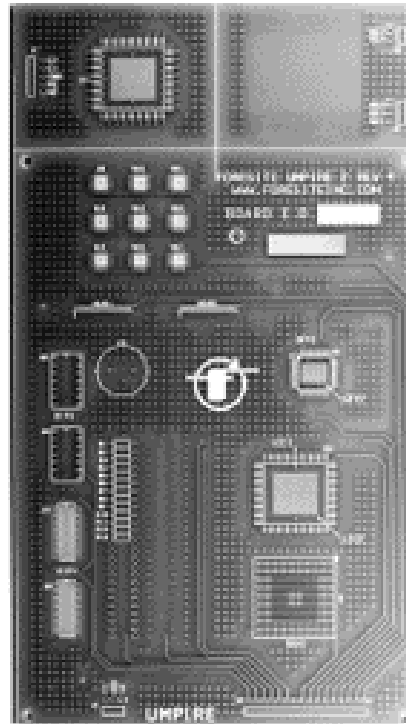

v

view

Board size: 5.2" x 9.4", .062" thick.

Notes

- Board finishes available are:
Immersion Silver, ENIG, Bare Copper, OSP and HASL.

Optimize the stencil printing and reflow portions of SMT assembly with this SMTA test vehicle.

Consumer demand has accelerated the pace of the electronics miniaturization trend, compelling assemblers to develop robust capabilities for 01005 components and 0.3mm pitch array packages in order to remain competitive.

The process of acquiring these capabilities can be complex, as they involve numerous interactive factors. To optimize the stencil printing and reflow portions of SMT assembly given the challenging new realities, a process evaluation tool has been developed that provides a turnkey solution for solder paste performance testing.

0.5 mm pitch area arrays and 0201 chip components are considered mainstream SMT; however many assemblers continue to struggle with yields on these packages. 0.4 mm area array and 01005 components are becoming more popular in design communities, and production levels are ramping up as electronic manufacturing service providers work to develop robust processes on their SMT lines. 0.3 mm pitch devices are emerging in highly miniaturized, high-value devices, and 0.25 mm pitch and 008004 chip components are in advanced assembly technology labs for initial process development.

Given the challenging new realities, a process evaluation tool has been developed that provides a turnkey solution for solder paste performance testing.

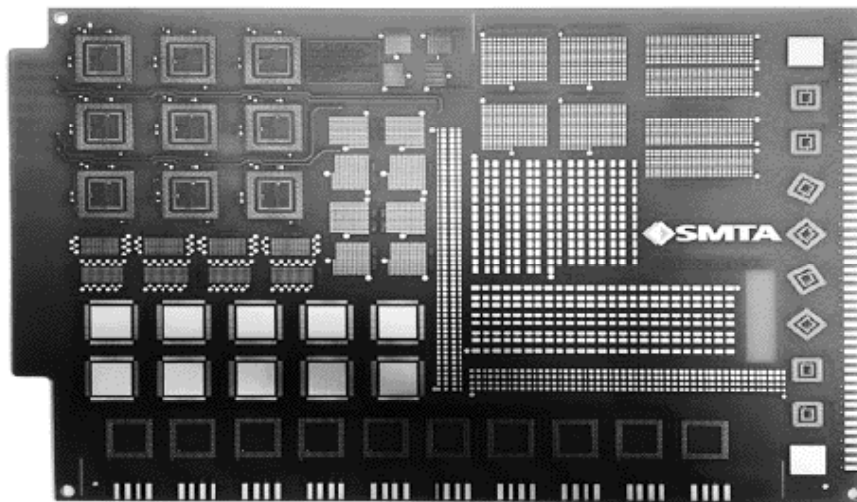

SMTA-H Kit

Part Description	Quantity Per Kit
PCB-SMTA-H	1
CVBGA368-.3mm-8mm-DC	8
CTBGA228-.5mm-12mm-DC	10
MLF100-12mm-.4mm-DC	10
1206SMR	50
1206SMC	50
0603SMR	50
0603SMC	50
0402SMR	400
0402SMC	400
0201SMR	400
0201SMC	400
01005SMR	400
01005SMC	400

Notes

- Board finishes available are: Immersion Silver, ENIG, and OSP.
- Gerber Data and X, Y Theta Data are available at no charge.

Custom PC Practice Boards and Kits

Design Custom PC Practice Boards Or Complete Kits
To Meet Your Specific Requirements.

Practical Components will help you design custom practice PC boards or complete kits. Use the building blocks below to create your board and start saving time and money using dummy parts and a PCB practice kit. Please contact your service representative for more information. Practical PC boards are non-solder mask defined.

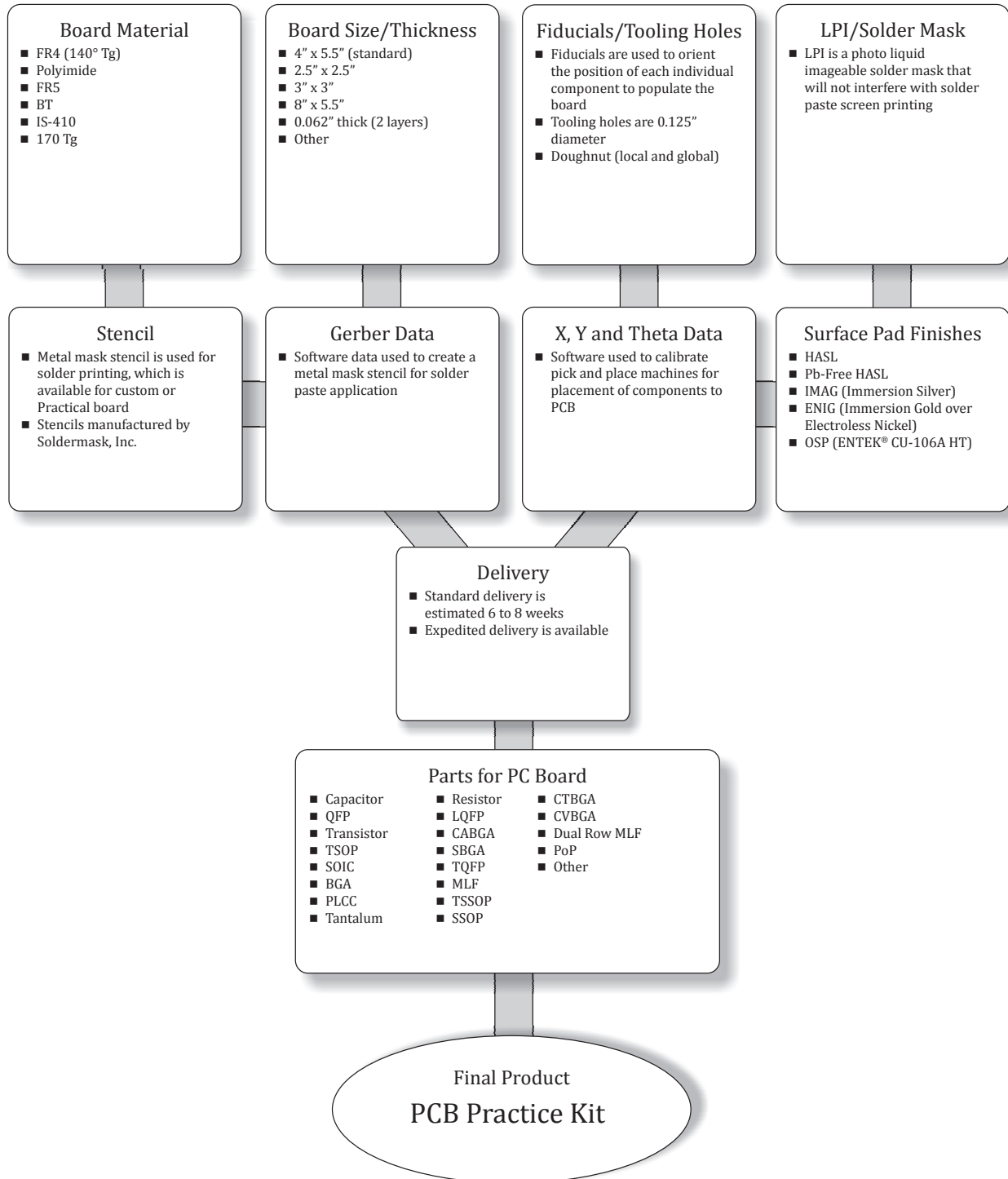

The kits listed below are for Hand Assembly. Each kit is prepackaged as an individual kit. Each component is bagged and labeled for identification. The test board is also individually bagged. Both kit and test board are put in a cardboard box that identifies the kit contents. Kits can be customized to meet specific needs. Please call regarding availability of Lead-Free single pack soldering kits.

Reference List for Single Pack Kits

Part Number Tin-Lead / Lead-Free	Kit Part Description	Description	IPC Reference	Page Number
10680 / 12086	PC003	Hand Solder Kit, 2.5" square		105
NA / 19314	PC007T-0-01	MLF Hand Assembly Kit		108
NA / 19463	PC007K-0-01	MLF / Fine Pitch SMT (top and bottom)		108
19266 / 16561	PC009	Mixed Technology Kit		112
11019 / 11021	PC011-0-01	Fine Pitch BGA Kit (0.4, 0.5, 1.0mm)		113
15848 / 19742	PC012-0-01	Global BGA Test Kit (1.0mm and 1.27mm pitch)		114
15923 / 19462	PC012T-0-01	Global BGA Test Kit (topside only, 1.0mm pitch)		114
15924 / 19991	PC012B-0-01	Global BGA Test Kit (bottomside only, 1.27mm pitch)		114
15212 / 16792	PC013-K	Through Hole Kit (with wires and terminals)		116
15213 / 16791	PC013-BTK	Through-Hole Kit (no wires or terminals)		114
15214 / 19409	PC013-RWTK-1	Recertification Kit (with wires and terminals)		114
15215 / 19308	PC013-RK	Recertification Kit (no wires or terminals)		114
17758 / 17759	PC015-0-01-STD	Rework Kit (unassembled)	7711/7721	118
17756 / 17757	PC015-0-01-RWK	Rework Kit (assembled)	7711/7721	118
18063 / 18064	PC016-J-STD	Mixed Tech Kit	J-Std-001 Rev F	119
15220 / 15224	WTK-1	Wires and Terminals (with or without holder)		106



Looking for Lead-Free?

This symbol indicates that lead-free parts are available!

Terminal and Wire Kit

The WTK-1 Kit includes everything needed to train and practice your wire soldering skills. This kit contains three different gauges of wire and five styles of terminals representative of what is available in the marketplace. Our kit also comes standard with a Terminal Holder. This reusable tool safely holds terminals during wiring and soldering operations. Terminals will fit snug in holes of the TB01 when the holder is new. The holes are intentionally slightly undersized to allow for expansion with use. Each kit comes individually packaged with all components bagged and tagged for easy identification. Perfect for classroom settings.

WTK-1 Kit

Part Description	Quantity Per Kit	Order Number
TB01 — Terminal Holder	1	11229
Turret Terminal	5	11228
Bifurcated Terminal	5	11224
Hook Terminal	5	11227
Pierced Terminal	5	11226
Cup Terminal	5	11301
22 Gauge Wire	3'	16163
20 Gauge Wire	3'	16164
26 Gauge Wire	3'	16162

Notes

- Kit is available without terminal holder.

Available as a

Single Pack Kit

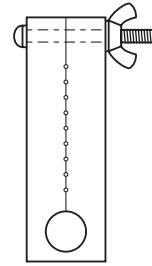

TB-01 Terminal Holder

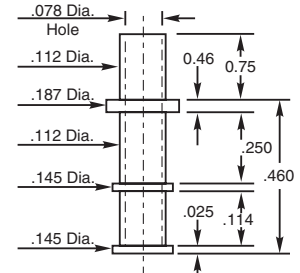

Turret Terminal

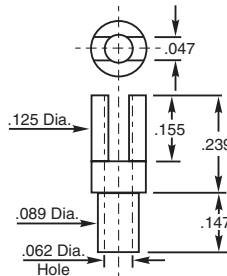

Bifurcated Terminal

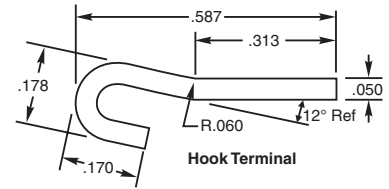

Hook Terminal

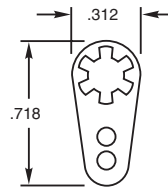

Pierced Terminal

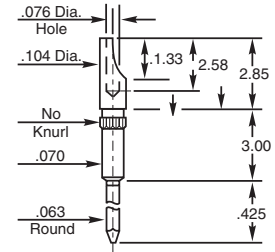

Gold Cup Terminal

Measurements are in inches.

PC003 Solder Practice Board and Kit



Tin-Lead and Lead-Free Kits are available

The PC003 hand solder practice kit is a low cost, effective kit for training and testing employees. This double-sided board has pads for 13 different components: One through-hole Dip14 and twelve surface-mount components. Each item is individually bagged and tagged for easy identification. Kits consist of PLCCs, SOICs, TSSOPs, SOTs, Passives, and QFPs with 0.5mm and 0.65mm pitch. This low cost kit is ideal for classroom training and practice. IPC-A-610 Rev D compliant. Kit is available with Tin-Lead or Lead-Free components.



PCB003 Solder Practice Board

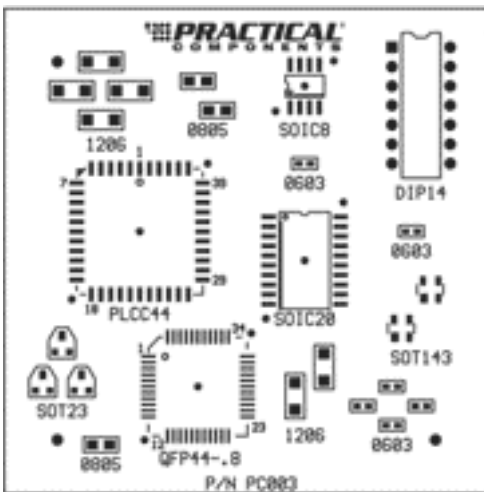

Top View

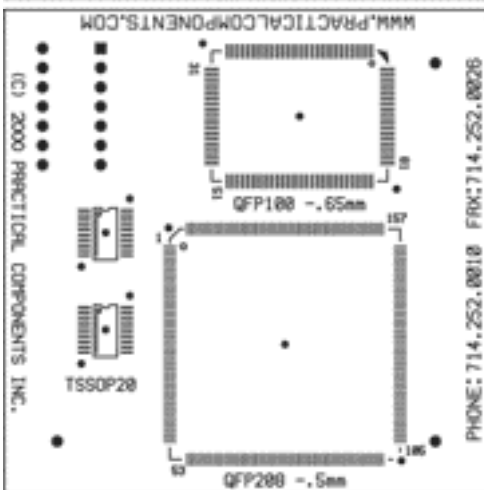

Bottom View

Board size: 2.5" x 2.5", .062" thick.

PC003 Solder Practice Board Kit (Tin-Lead and Lead-Free components available)

Part Description	Quantity Per Kit
PCB003 Board (customer to specify finish)	1
QFP208-28mm-.5mm-2.6mm	1
QFP44-10mm-.8mm-3.2mm	1
QFP100-14x20mm-.65mm-3.2mm	1
PLCC44	1
SO8GT-3.8mm	1
SO20GT-7.6mm	1
SOT23	3
SOT143	2
TSSOP20-4.4mm	2
0603SMR	6
0805SMR	3
1206SMR	6
DIP14T	1
Kit Order Number: (Tin-Lead)	PC003
Kit Order Number: (Lead-Free)	PC003-LF

Notes

- Gerber Data and X, Y Theta Data are available at no charge.
- Lead-Free parts are available with Sn finish.
- Board finishes available are:
Immersion Silver, ENIG, Bare Copper, OSP and HASL



Ordering Information

- Order Number: PCB003 Rev B (Board Only)

MLF[®] Test Board and Kits

REVISED [Rev. A]

This new PCB007 MicroLeadFrame[®] (MLF[®]) Test Board is two test boards in one. The top side of the board consists of daisy-chained MLF[®] pads. Amkor's new MLF[®] packages are a near CSP plastic encapsulated package with a copper leadframe substrate. MLF[®] packages have perimeter pads on the bottom of the package. Thermal enhancement is provided by Amkor's ExposedPad[™] technology.

The test board front side has land patterns for MLF[®] package sizes in varying I/O counts. Lead pitches of these include 0.5mm, 0.65mm and 0.8mm. The MLF[®] side of the PCB007 board is designed to help customers become more familiar with the placement and process characteristics of MLF[®] packages. The wide assortment of pad sizes and pitches provide a

comprehensive overview of MLF[®] packages. Daisy-chain patterns on the PCB007 board complement the patterns on the components, allowing continuity to be tested (except for TSOP's and T/LQFP120).

The bottom side of the PCB007 Test Board provides a variety of SMD component types. The bottom of the board has T/LQFP component with 0.4mm pitch, pads for the PBGA256 component with a 1.00mm pitch and two TSOP Type II components with 0.8mm pitch. Standard board finish for the PCB007 is Immersion Silver. Other finishes are available upon request. Standard board thickness is 0.062". Customers always have the option of mixing and matching components to suit their requirements.

PCB007 MLF Test Board

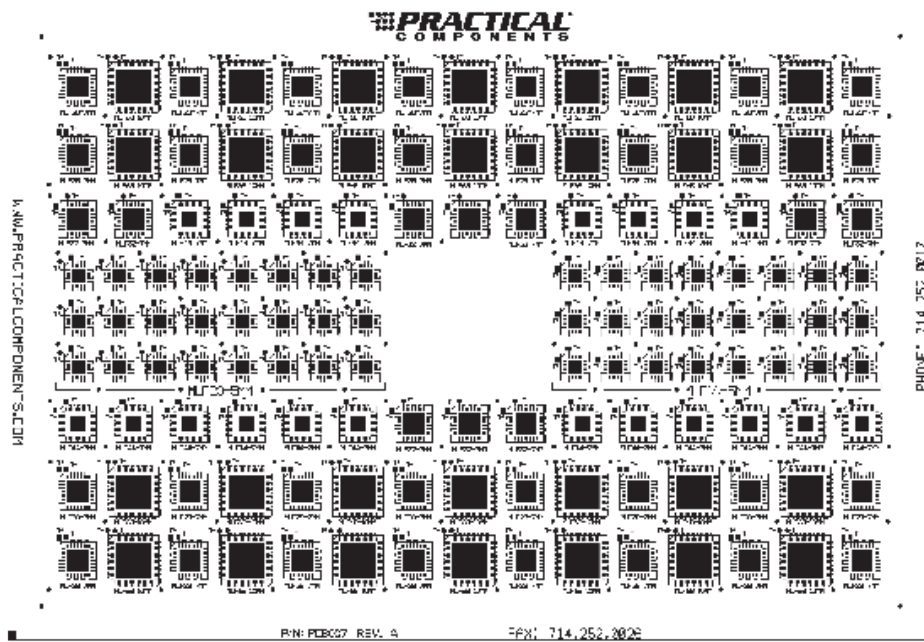

Single Pack Kit

IPC Compliant

Top view

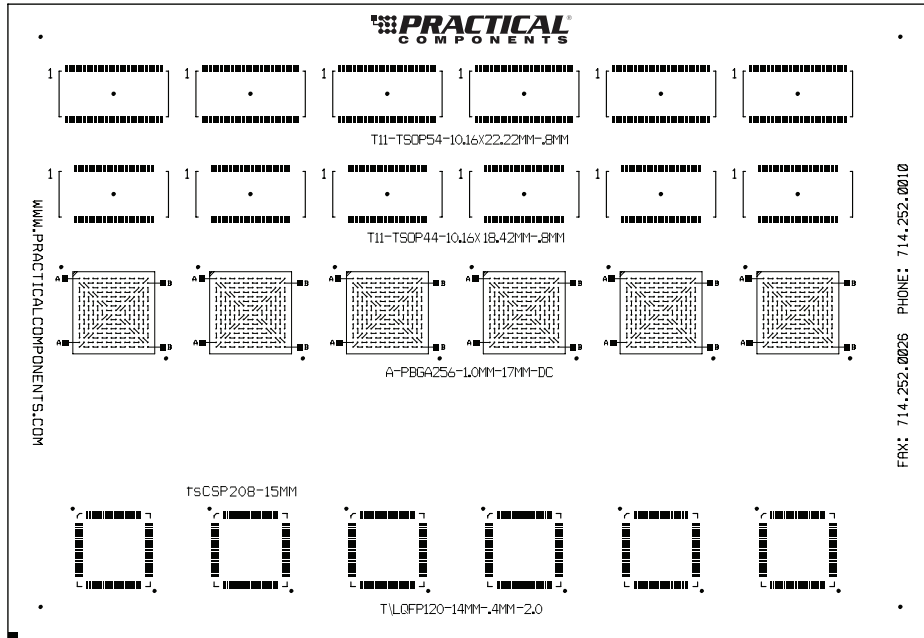

Software and Data Files Included With All Kits!

Bottom view
Board size: 8" x 5.5", .062" thick.

MLF® Test Board and Kits

PC007 MLF® Kits

Part Description	Quantity Per 1 Kit	Quantity Per 10 Kits	Quantity Per 25 Kits	Quantity Per 50 Kits
Kit Order Number (Top and Bottom):	PC007K-0-01	PC007K-0-10	PC007K-0-25	PC007K-0-50
A-MLF16-5mm-.8mm-DC	24	240	600	1,200
A-MLF20-5mm-.65mm-DC	24	240	600	1,200
A-MLF28-7mm-.8mm-DC	32	320	800	1,600
A-MLF32-7mm-.65mm-DC	10	100	250	500
A-MLF44-7mm-.5mm-DC	20	200	250	1,000
A-MLF68-10mm-.5mm-DC	28	280	700	1,400
A-T/LQFP120-14mm-.4mm-2.0	6	60	150	300
PBGA256-1.0mm-17mm-DC	6	60	150	300
T11-TSOP44-10.16x18.42mm-.8mm	6	60	150	300
T11-TSOP54-10.16x22.22mm-.8mm	6	60	150	300
PCB007 Test Board	1	10	25	50

Part Description	Quantity Per 1 Kit	Quantity Per 10 Kits	Quantity Per 25 Kits	Quantity Per 50 Kits
Kit Order Number (Bottom Only):	PC007B-0-01	PC007B-0-10	PC007B-0-25	PC007B-0-50
A-T/LQFP120-14mm-.4mm-2.0	6	60	150	300
PBGA256-1.0mm-17mm-DC	6	60	150	300
T11-TSOP44-10.16x18.42mm-.8mm	6	60	150	300
T11-TSOP54-10.16x22.22mm-.8mm	6	60	150	300
PCB007 Test Board	1	10	25	50

Part Description	Quantity Per 1 Kit	Quantity Per 10 Kits	Quantity Per 25 Kits	Quantity Per 50 Kits
Kit Order Number (Top Only):	PC007T-0-01	PC007T-0-10	PC007T-0-25	PC007T-0-50
A-MLF16-5mm-.8mm-DC	24	240	600	1,200
A-MLF20-5mm-.65mm-DC	24	240	600	1,200
A-MLF28-7mm-.8mm-DC	32	320	800	1,600
A-MLF32-7mm-.65mm-DC	10	100	250	500
A-MLF44-7mm-.5mm-DC	20	200	250	1,000
A-MLF68-10mm-.5mm-DC	28	280	700	1,400
PCB007 Test Board	1	10	25	50

Notes

- Kit quantities are subject to change.
- Mix and match components and quantities to create a custom kit. Please contact your sales representative for details.
- Components supplied in kits (except for TSOP's and T/LQFP120) have pairs of leads shorted together in a daisy-chain pattern that result in a line of continuity when combined with the shorted pairs of pads on the board. Continuity test pads on the board allow the end user to verify electrical connections at solder joints and to identify electrical opens.
- Gerber and X, Y Theta data included at no charge.
- Digitized files provided by Aegis Software included at no charge.
- PBGA is available with SAC305 or SAC405 Lead-Free solder ball alloy's.
- Board finishes available are:
Immersion Silver, ENIG, Bare Copper, OSP and HASL.

Lead-Free Part Description List

Part Description

A-MLF16-5mm-.8mm-DC-Sn
 A-MLF20-5mm-.65mm-DC-Sn
 A-MLF28-7mm-.8mm-DC-Sn
 A-MLF32-7mm-.65mm-DC-Sn
 A-MLF44-7mm-.5mm-DC-Sn
 A-MLF68-10mm-.5mm-DC-Sn
 A-T/LQFP120-14mm-.4mm-2.0-Sn
 PBGA256-1.0mm-17mm-DC-SAC305
 T11-TSOP44-10.16x18.42mm-.8mm-Sn
 T11-TSOP54-10.16x22.22mm-.8mm-Sn



Solder Practice Board and Kits

REVISED [Rev. H]

A universal PCB to meet all your needs.

Rework practice, solder training and evaluation, and for testing and calibration of pick-and-place machines.

PCB008 Solder Practice Board

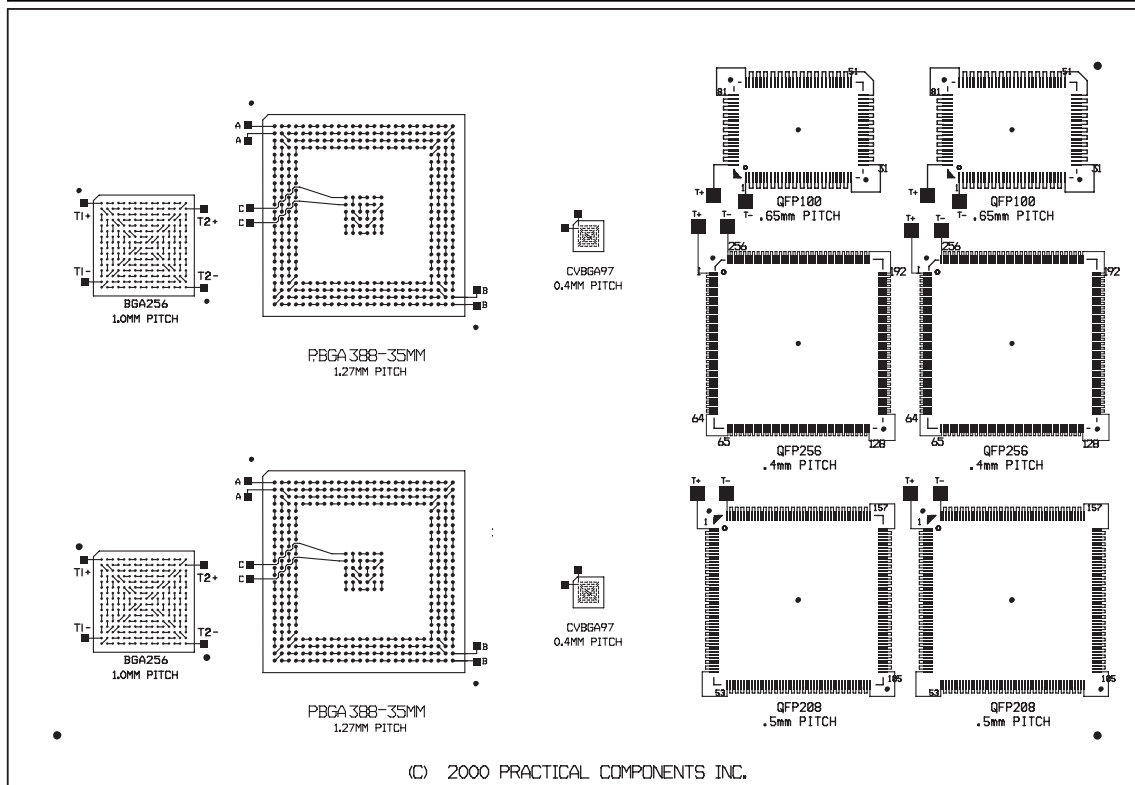
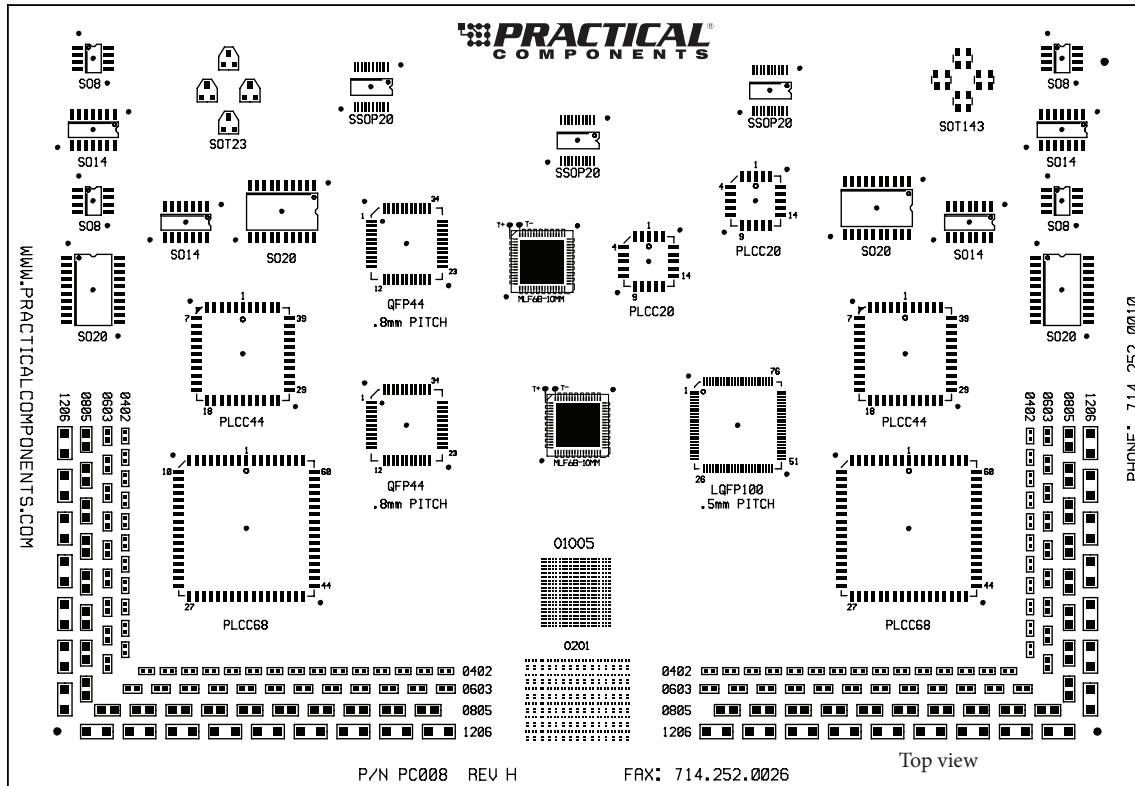

Choose from the kits below or create your own custom configuration.

Lead-Free Components List
(included in a complete kit)

Part Description	Quantity Per Board
MLF68-10mm-.5mm-DC-Sn	2
PBGA256-1.0mm-17mm-DC-LF	2
CVBGA97-.4mm-5mm-DC-LF	2
PBGA388-1.27mm-35mm-DC-LF	2
QFP44-10mm-.8mm-3.9mm-Sn	2
QFP100-14x20mm-.65mm-3.9mm-DC-Sn	2
QFP208-28mm-.5mm-2.6mm-DC-Sn	2
QFP256-28mm-.4mm-2.6mm-DC-Sn	2
LQFP100-14mm-.5mm-2.0mm-Sn	1
PLCC20-Sn	2
PLCC44-Sn	2
PLCC68-Sn	2
SO8-3.8mm-Sn	4
SO14-3.8mm-Sn	4
SO20-7.6mm-Sn	4
SSOP20-5.3mm	3
01005SMR-Sn	200
SOT23-TR-Sn	4
SOT143-TR-Sn	4
0201SMR-Sn	180
0402SMR-Sn	52
0603SMR-Sn	42
0805SMR-Sn	36
1206SMR-Sn	32
PCB008 Board (customer to specify finish)	1

Tin-Lead Components List
(included in a complete kit)

Part Description	Quantity Per Board
MLF68-10mm-.5mm-DC	2
PBGA256-1.0mm-17mm-DC	2
CVBGA97.4mm-5mm-DC	2
PBGA388-1.27mm-35mm-DC	2
QFP44-10mm-.8mm-3.9mm	2
QFP100-14x20mm-.65mm-3.9mm-DC	2
QFP208-28mm-.5mm-2.6mm-DC	2
QFP256-28mm-.4mm-2.6mm-DC	2
LQFP100-14mm-.5mm-2.0mm	1
PLCC20	2
PLCC44	2
PLCC68	2
SO8-3.8mm	4
SO14-3.8mm	4
SO20-7.6mm	4
SSOP20-5.3mm	3
01005SMR	200
SOT23-TR	4
SOT143-TR	4
0201SMR	180
0402SMR	52
0603SMR	42
0805SMR	36
1206SMR	32
PCB008 Board-HASL finish	1

Notes

- Gerber Data and X, Y Theta Data are available if required at no charge.
- Digitized files provided by Aegis Software included at no charge.
- Kit is available with Lead-Free components (for Tin-Lead and Lead-Free kits). Substitutions may occur depending on availability of lead-free finishes and alloys.
- PBGAs are available with SAC305 or SAC405 Lead-Free alloys.
- CVBGA is available with SAC105, SAC305 or SAC405 Lead-Free alloys.
- Add "LF" to end of Kit Order Number when ordering Lead-Free kits.
- Board finishes available are:
Immersion Silver, ENIG, Bare Copper, OSP and HASL.

Ordering Information

- Order Number: PCB008 Rev H (Board Only)



Mixed Technology Board and Kit



The PC009 Mixed Technology kit has surface mount components and through-hole components. This kit's primary use is for hand soldering but is also available as machine run upon special request. Tin-Lead and Lead-Free components available. Through-hole components are placed in

close proximity to surface mount components to represent real soldering situations. Components are individually bagged and identified for component recognition.

PCB009 Mixed Technology Board

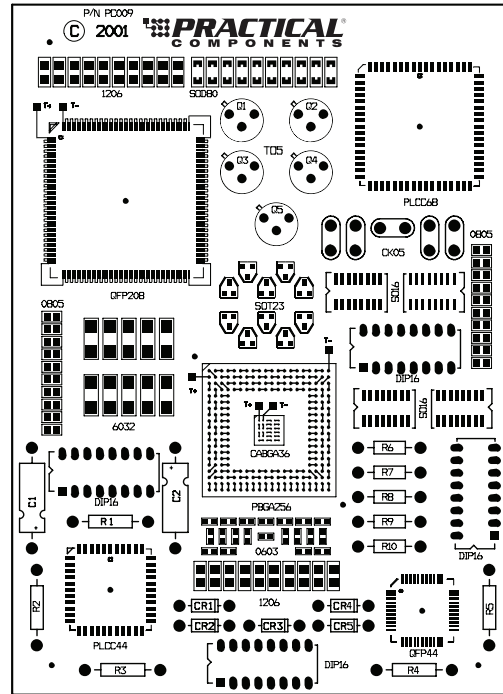

Board size: 4" x 5.5", .062" thick.

PC009 Mixed Technology Kits

Part Description	Quantity per 1 Kit	Quantity per 5 Kit	Quantity per 10 Kit	Quantity per 20 Kit
PCB009 Board	1	5	10	20
SMD Components				
A-PBGA256-1.27-27mm-DC **	1	5	10	20
A-CABGA36-.8mm-6mm-DC **	1	5	10	20
QFP44-10MM-.8MM-3.2	1	5	10	20
SOT23-TR	10	50	100	200
PLCC44	1	5	10	20
PLCC68	1	5	10	20
SOD80-TR	10	50	100	200
SO16GT-3.8mm	4	20	40	80
6032SMTA	10	100	200	400
0603SMR-TR	20	100	200	400
0805SMR-TR	20	100	200	400
1206SMR-TR	20	100	200	400
Through-Hole Components				
DPIP16T	4	20	40	80
1/4 Watt Axial Resistors	5	25	50	100
1/2 Watt Axial Resistors	5	25	50	100
CK05 (with Spacers)	5	25	50	100
T05 (with Spacers)	5	25	50	100
5x11 Axial Electrolytic	2	10	20	2
DO34 or DO35	5	25	50	5
Kit Order Number: (Tin-Lead)	PC001-0-01	PC001-0-05	PC001-0-10	PC001-0-20
Kit Order Number: (Lead-Free)	PC009-0-01-LF	PC009-0-05-LF	PC009-0-10-LF	PC009-0-20-LF



Notes

- **BGA/CABGA Packages are not included in kit. Either BGA or CABGA can be added to kit upon request.
- Mix and match components and quantities to create a custom kit.
- Gerber Data and X, Y Theta Data are available at no charge.
- Not all parts are available lead-free.
- Board finishes available are: Immersion Silver, ENIG, Bare Copper, OSP and HASL.

BGA Fine Pitch Board and Kit

REVISED [Rev. E]

Tin-Lead and Lead-Free Available

The PC011 BGA Kit contains Amkor daisy-chained fine pitch BGAs. The daisy-chain PCB011 test board contains patterns for the 0.4mm pitch, 0.5mm pitch and 1.0mm pitch CSP/BGA components. Amkor BGA type components on the board are the CTBGAs, CVBGAs and PBGAs. The

PCB011 test board is double sided. This test board is designed to help the end user become familiar with smaller BGA body sizes and pitches. Components come in standard JEDEC trays. Kit component quantities are for one side of the board only.

PCB011 BGA Fine Pitch Board

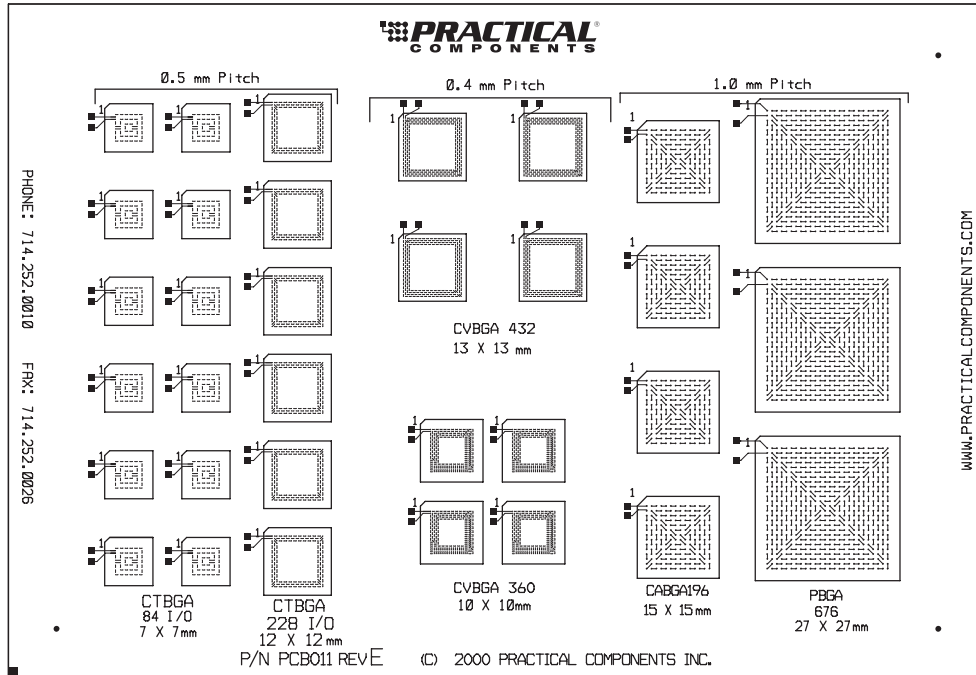

Board size: 8" x 5.5", .062" thick.

PC011 BGA Kits

Part Description	Quantity Per 1 kit	Quantity Per 10 kits	Quantity Per 25 kits
A-CTBGA84-.5mm-7mm-DC-SAC305	12	120	300
A-CTBGA228-.5mm-12mm-DC-SAC305	6	60	150
A-CVBGA360-.4mm-10mm-DC-SAC305	4	40	100
A-CVBGA432-.4mm-13mm-DC-SAC305	4	40	100
A-CABGA196-1.0mm-15mm-DC-SAC305	4	40	100
A-PBGA676-1.0mm-27mm-DC-SAC305	3	30	75
PCB011-RevE	1	10	25
Kit Order Number: (Tin-Lead)	PC011-0-01	PC011-0-10	PC011-0-25
Kit Order Number: (Lead-Free)	PC011-0-01-LF	PC011-0-10-LF	PC011-0-25-LF



Notes

- Gerber and X, Y Theta data included at no charge.
- Digitized files provided by Aegis Software included at no charge.
- PBGAs are available with SAC305 or SAC405 solder ball alloys. CVBGA and CTBGA are available with SAC305, SAC405 or SAC105 solder ball alloys.
- Board finishes available are:
Immersion Silver, ENIG, Bare Copper, OSP and HASL

Order numbers for individual items

Part Description	Order Number
A-CTBGA84-.5mm-7mm-DC-SAC305	31317
A-CTBGA228-.5mm-12mm-DC-SAC305	31329
A-CVBGA360-.4mm-10mm-DC-SAC305	32210
A-CVBGA432-.4mm-13mm-DC-SAC305	31439
A-CABGA196-1.0mm-15mm-DC-SAC305	31503
A-PBGA676-1.0mm-27mm-DC-SAC305	31019
PCB011-RevE	TBD

BGA Global Daisy-Chain Test Kit

PCB012 BGA Global Daisy-Chain Test Board

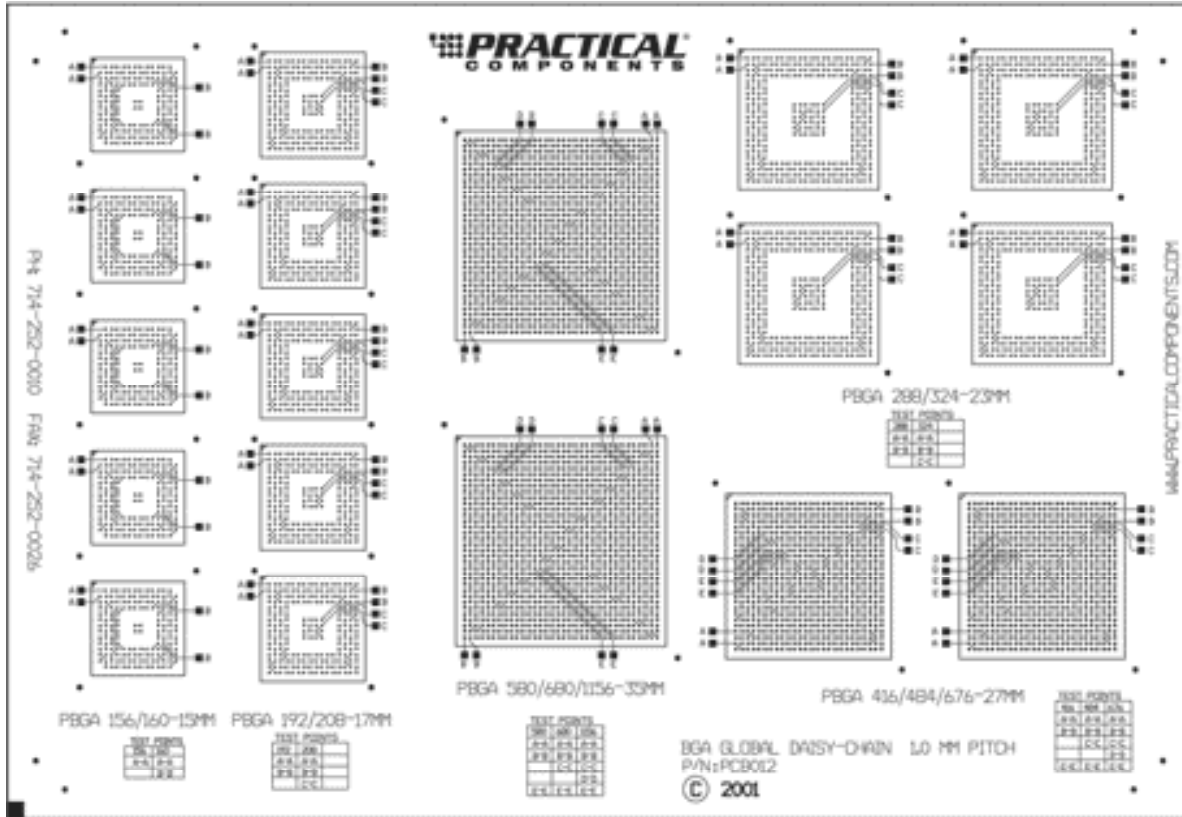

Top view

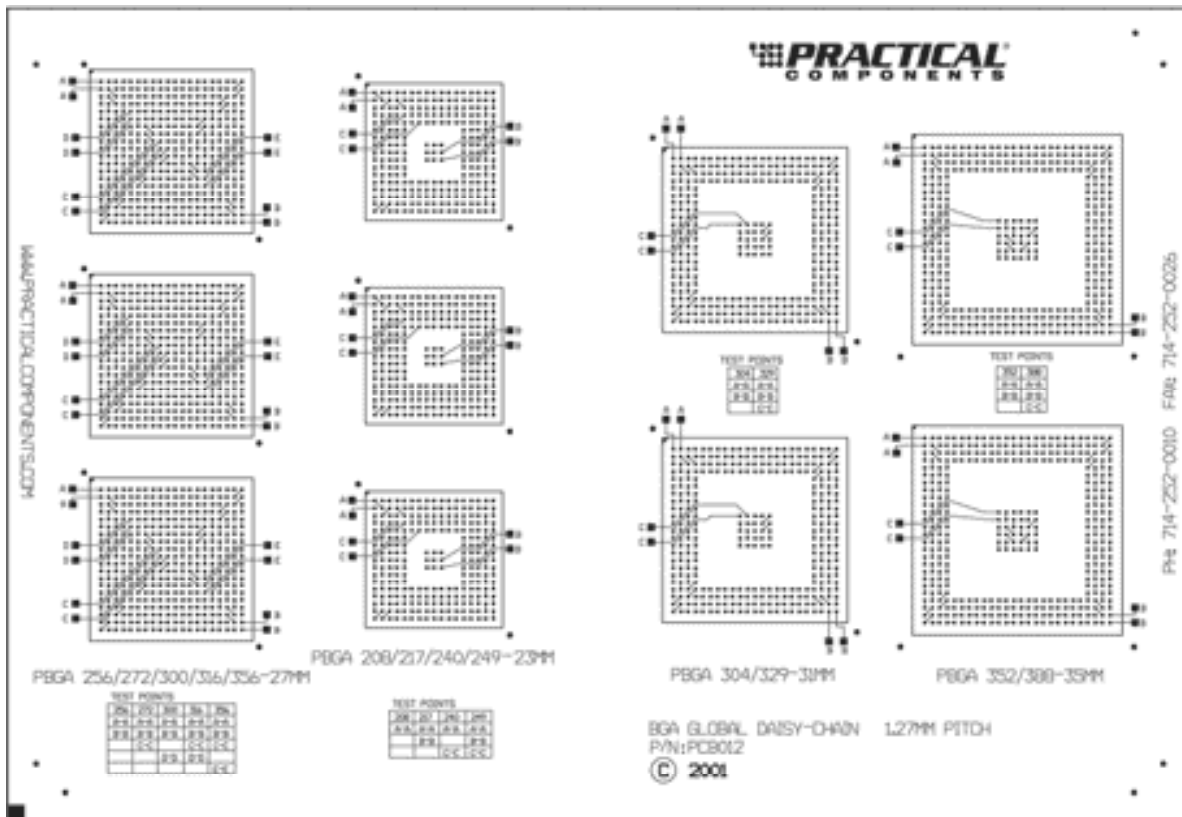

Bottom view

Board size:
8" x 5.5", .062" thick.

BGA Global Daisy-Chain Test Kit

Tin-Lead and Lead-Free Available!

The New PCB012 Global Daisy-Chain test board has 25 different BGA land patterns. Board pads accommodate BGA components ranging from 17mm square to 35mm square. The PCB012 test board has 1.00mm and 1.27mm pitch pads. BGA components placed on this test board range from 208 to 1,156 balls. Daisy-chain patterns on the PCB012 board compliment the patterns on the components, allowing continuity to be tested. Each pad on

the board has multiple daisy-chain patterns. These multiple daisy-chained pads allow different ball-count PBGA components to be placed on the same pad. Each pattern has test points to check for continuity. There are ball-count to test-point legends on the board. The board is double-sided with different pad sizes on the top and bottom. Customers can mix and match components to suit their requirements.

PC012 BGA Global Daisy-Chain Test Kit

1.0mm Pitch—Top Side						
Part Number	Part Description		Quantity Per 1 Kit	Quantity Per 5 Kit	Quantity Per 10 Kit	Quantity Per 25 Kit
30542	A-PBGA208-1.0mm-17mm-DC	5 Pads	5	25	50	125
31358	A-PBGA208-1.0mm-17mm-DC-LF-305	Per Board				
30362	A-PBGA324-1.0mm-23mm-DC	4 Pads	4	20	40	20
31359	A-PBGA324-1.0mm-23mm-DC-LF-305					
30513	A-PBGA288-1.0mm-23mm-DC	2 Pads	2	10	20	50
31352	A-PBGA288-1.0mm-23mm-DC-LF-305					
31083	A-PBGA676-1.0mm-27mm-DC	2 Pads	2	10	20	50
31019	A-PBGA676-1.0mm-27mm-DC-LF-305					
30604	A-PBGA484-1.0mm-27mm-DC	2 Pads	2	10	20	50
31312	A-PBGA484-1.0mm-27mm-DC-LF-305					
31123	A-PBGA1156-1.0mm-35mm-DC	2 Pads	2	10	20	50
31306	A-PBGA1156-1.0mm-35-DC-LF-305					
30343	A-PBGA680-1.0mm-35mm-DC	2 Pads	2	10	20	50
31345	A-PBGA680-1.0mm-35mm-DC-LF-305					

1.27mm Pitch—Bottom Side						
Part Number	Part Description		Quantity Per 1 Kit	Quantity Per 5 Kit	Quantity Per 10 Kit	Quantity Per 25 Kit
30543	A-PBGA208-1.27mm-23mm-DC	3 Pads	3	15	30	75
31432	A-PBGA208-1.27mm-23mm-DC-LF-305	Per Board				
30047	A-PBGA256-1.27mm-27mm-DC	3 Pads	3	15	30	75
31020	A-PBGA256-1.27mm-27mm-DC-LF-305					
30372	A-PBGA272-1.27mm-27mm-DC	2 Pads	2	10	20	50
31309	A-PBGA272-1.27mm-27mm-DC-LF-305					
30645	A-PBGA304-1.27mm-31mm-DC	2 Pads	2	10	20	50
30832	A-PBGA304-1.27mm-31mm-DC-LF-305					
30644	A-PBGA329-1.27mm-31mm-DC	2 Pads	2	10	20	50
31476	A-PBGA329-1.27mm-31mm-DC-LF-305					
30065	A-PBGA388-1.27mm-35mm-DC	2 Pads	2	10	20	50
31310	A-PBGA388-1.27mm-35mm-DC-LF-305					

Notes

- Kit quantities are subject to change.
- Mix and match components and quantities to create a custom kit. Please contact your sales representative for details.
- Board is double sided (top side for 1.0mm pitch packages / bottom side for 1.27mm pitch package)
- Gerber and X, Y Theta data included at no charge.
- Digitized files provided by Aegis Software included at no charge.
- PBGA available as SAC405 but SAC305 is the preferred Alloy.
- Board finishes available are:
Immersion Silver, ENIG, Bare Copper, OSP and HASL.

	Description
Top	PC012T-0-01
Top Lead Free	PC012T-0-01-LF
Bottom	PC012B-0-01
Bottom Lead Free	PC012B-0-01-LF
Complete	PC012K-0-01
Complete Lead Free	PC012K-0-01-LF

Through-Hole Solder Training Kits

Choose from four different variations of the PC013 kit

The PC013 hand solder practice kit is an effective way to evaluate or train employees and students. This versatile board comes with a variety of through-hole components and each kit is conveniently boxed and the components are individually bagged and labeled for easy

identification. It is available in several different options to meet each company's requirements. Kits come standard with an SO16 resistor network, but can be upgraded to a Flat Pack 16. This kit is ideal for classroom settings.

PCB013 Board

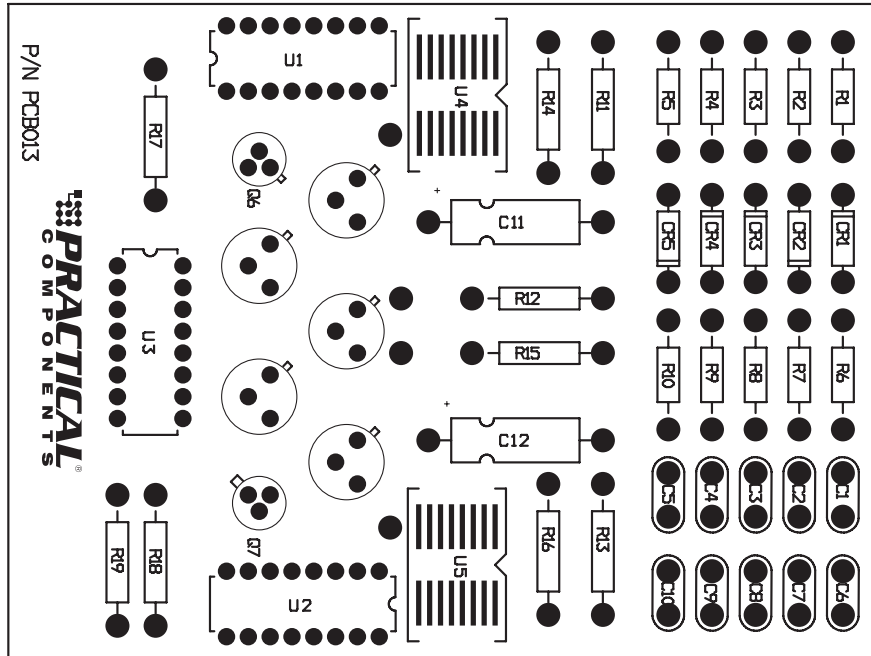

Board size: 4" x 3", .062" thick.

Complete Through-Hole Kit

Part Description	Quantity Per Kit
PCB013	2
Turret Terminal	15
Bifurcated Terminal	15
Hook Terminal	15
Pierced Terminal	15
Cup Terminal	15
DO35	10
AE-5x12	4
CK05	20
CK05 Spacer	20
1/4-W-AR	20
1/2-W-AR	18
DIP16	6
TO5	10
TO18	4
TO5/18 Spacer	14
SO16GT-3.8mm	4
20 Gauge Wire	3'
22 Gauge Wire	3'
26 Gauge Wire	3'
Order Number: (Tin-Lead)	PC013-K
Order Number: (Lead-Free)	PC013-K-LF

Recertification Kit With Wires And Terminals

Part Description	Quantity Per Kit
PCB013	1
Turret Terminal	5
Bifurcated Terminal	5
Hook Terminal	5
Pierced Terminal	5
Cup Terminal	5
DO35	2
AE-5x12	1
CK05	6
CK05 Spacer	6
1/4-W-AR	5
1/2-W-AR	3
DIP16	2
TO5	2
TO18	2
TO5/18 Spacer	4
SO16GT-3.8mm	1
20 Gauge Wire	3'
22 Gauge Wire	
26 Gauge Wire	3'
Order Number: (Tin-Lead)	PC013-RWTK-1
Order Number: (Lead-Free)	PC013-RWTK-1-LF

Basic Through-Hole Kit

Part Description	Quantity Per Kit
PCB013	2
DO35	10
AE-5x12	4
CK05	20
CK05 Spacer	20
1/2-W-AR	18
1/4-W-AR	20
DIP16	6
TO5	10
TO18	4
TO5/18 Spacer	14
SO16GT-3.8mm	4
Order Number: (Lead-Free)	PC013-BTK-LF
Order Number: (Tin-Lead)	PC013-BTK

Recertification Kit

Part Description	Quantity Per Kit
PCB013	1
DO35	2
AE-5x12	1
CK05	6
CK05 Spacer	6
1/4-W-AR	5
1/2-W-AR	3
DIP16	2
TO5	2
TO18	2
TO5/18 Spacer	4
SO16GT-3.8mm	1
Order Number: (Tin-Lead)	PC013-RK
Order Number: (Lead-Free)	PC013-RK-LF

Notes

- Board finishes available are: Immersion Silver, ENIG, Bare Copper, OSP and HASL.

Available as a

Single Pack Kit



IPC 9850 Attribute Defect Rate Kit

IPC 9850 Kit

Attribute Defect Rate Kit checks out pick and place machines.

IPC-9850 includes test methods for determining various SMT placement equipment attributes, including repeatability, accuracy and attribute defects. Each of these tests requires specific material and this new test board and kit from Practical Components provides the solution for conducting the attribute rate defect testing. The applicable section from IPC-9850 is 4.1, where attribute defects are defined as components placed upside down, tombstoned, on side, missing or extra part, damaged lead(s), damaged part(s), completely off land, or wrong polarity. Testing requires the placement of 88,000 components on 20 boards to attain reasonably accurate test results. Practical Components 9850 Kit will provide you with enough components and boards to meet this guideline. While IPC-9850 requires the placement of components on sticky tape (included), these boards can also be printed with solder paste and reflowed.

Each board contains the lands (multiple orientations) for 4,400 components (440 SOT23s, 440 SO8s, 880 0603SMCs, 880 0603 SMRs, 880 0402SMCs and 880 0402SMRs). Test material is available from Practical as single boards or complete kits with all the necessary dummy components. On request, this board comes with demonstration versions of CircuitCAM and CheckPoint manufacturing software, ready-to-run CircuitCAM Project Files (CPFs) and Gerber and X, Y Theta data at no extra charge.



PCB014 Board

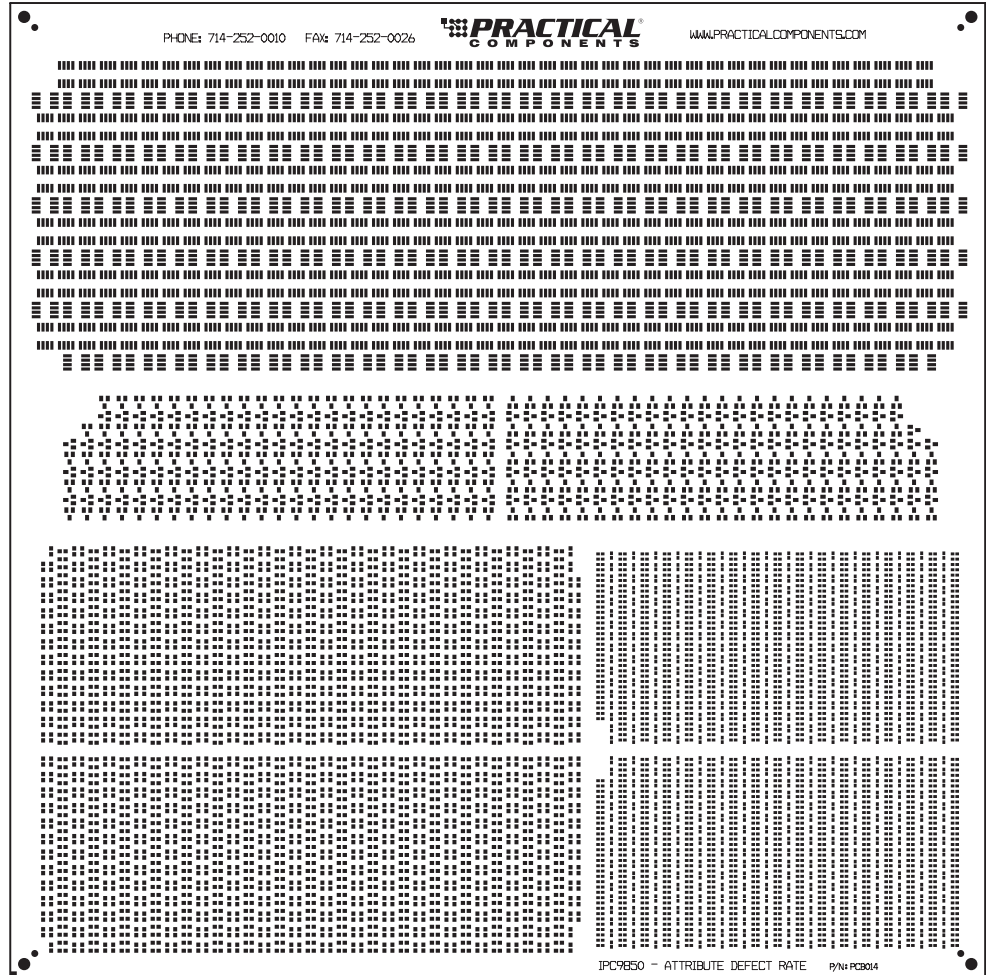

PC014 Kit (IPC 9850)

Board size: 11" x 11", .062" thick.

Part Description	Quantity Per 10 Kits	Quantity Per 25 Kits
SOT23-TR	6,000	15,000
SO8GTR-3.8mm	5,000	12,500
0402SMC-PL	10,000	50,000
0402SMR-PL	10,000	50,000
0603SMC-PL	12,000	50,000
0603SMR-PL	10,000	50,000
Sticky Tape	2 Rolls	3 Rolls
PCB014	10	25
Kit Order Number:	PC014-0-10	PC014-0-25

Notes

- Gerber Data and X, Y Theta Data are available, if required, at no charge.
- Digitized files provided by Aegis Software included at no charge.
- Only board finish available is HASL.

PC015 Rework Kit Conforms to IPC 7711/7721 Standards for reworking.

The PC015 Rev C Kit is ideal for rework training or evaluating current rework procedures. This kit contains 2 fully populated boards and replacement components to enable removing and replacing ½ of the components. Reworked solder joints can then be visually compared to original solder joints (on components not reworked) on the same board. Kit includes 2 boards which allows one to be used practice and one to be used for evaluation.

The IPC-7711/7721C Rework, Modification and Repair of Electronic Assemblies standard has

received a complete procedure by procedure update to assure applicability to both lead free and traditional SnPb soldered assemblies. Included in this revision are the procedures previously released as change pages, an updated general information and common procedures section, new procedures for BGAs using focused IR Reflow Systems with integral preheater and general updates to all other procedures.

This solder training kit conforms to IPC 7711/7721 and is the industry standard on electronics Rework, Repair and Modification.

It is perfect for classroom settings and can also be ordered unassembled as a standard hand solder training kit.

This kit includes everything needed for repair and rework of electronic assemblies and printed circuit boards!

This kit includes everything needed for repair and rework of electronic assemblies and printed circuit boards!

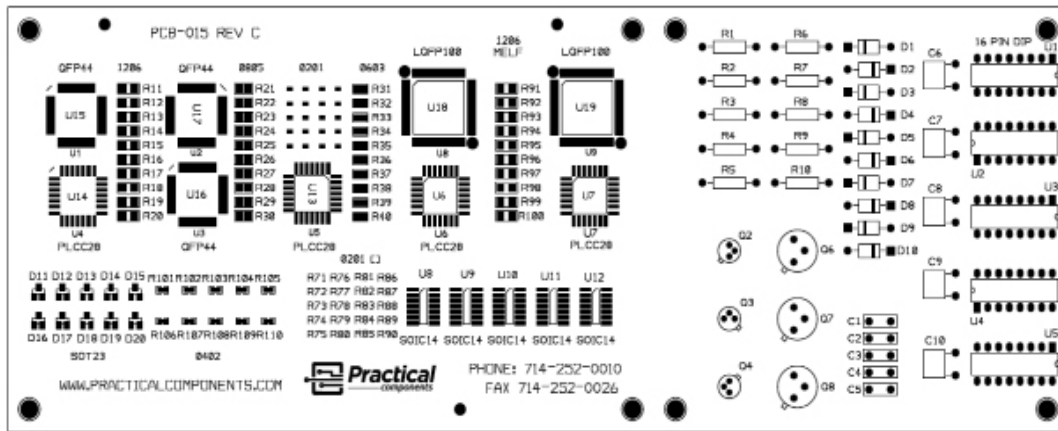

Board size: 9.850" x 3.750", .062" thick.

PC015 For Hand Assembly Kit

Part Description	Quantity Per Board
PCB015-Standard	1
1/4-W-AR	10
DO35	10
PDIP16T	5
TO18-B	3
TO5-3-B	3
TO5/TO18 SPACER	6
CK05-B-.2"LS	10
CK SPACER	10
0201SMR	20
0402SMR	10
0603SMR	10
0805SMR	10
1206MSR	10
1206SMR-MELF	10
QF44-10mm-.8mm-3.2	3
LQFP100-14mm-.5mm-2.0	2
DPAK(TO-252)	6
SOT23	10
SO14GT-3.8mm	5
PLCC28T	4

Kit Order Number: (Tin-Lead) PC015-0-01-STD-RevC
 Kit Order Number: (Lead-Free) PC015-0-01-STD-RevC-LF

PC015 Rework Kit Assembled

Part Description	Quantity Per Board
PCB015-Assembled	1
1/4-W-AR	10
DO35	10
PDIP16T	5
TO18-B	3
TO5-3-B	3
TO5/TO18 SPACER	6
CK05-B-.2"LS	5
CK SPACER	5
0201SMR	20
0402SMR	10
0603SMR	10
0805SMR	10
1206MSR	10
1206SMR-MELF	10
QF44-10mm-.8mm-3.2	3
LQFP100-14mm-.5mm-2.0	2
DPAK(TO-252)	6
SOT23	10
SO14GT-3.8mm	5
PLCC28T	4

Kit Order Number: (Tin-Lead) PC015-0-01-RWK-RevC
 Kit Order Number: (Lead-Free) PC015-0-01-RWK-RevC-LF

IPC Compliant Hand Soldering Kit



Tin-Lead and Lead-Free Kits Available

PCB-J-STD Board Soldering Kit Conforms to J-STD-001F Specifications

The PC016 Mixed Technology Kit is an effective and economical way to train and evaluate students and employees. This kit contains a variety of standard Surface Mount and Through-Hole components with traces to simulate real world situations. Each kit comes individually boxed with all components bagged and labeled for easy identification. Conforms to IPC J-STD-001F standard for soldering. In stock and ready to ship, this kit is perfect for classroom settings.

Available as a

Single Pack Kit

IPC Compliant

PCB-J-STD-F Board

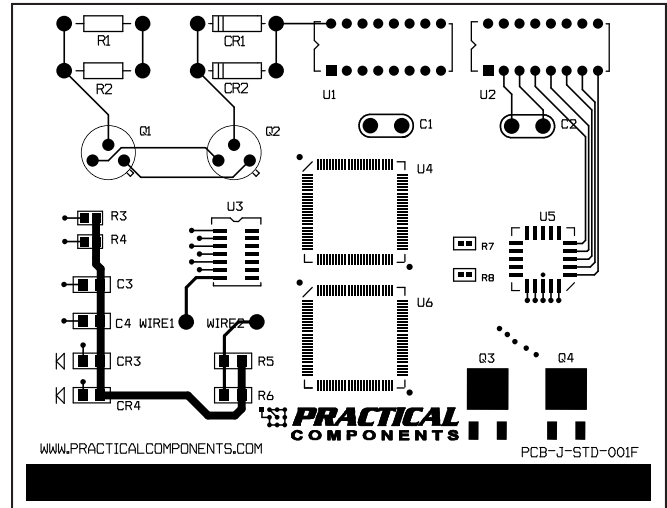

Board size: 4" x 3", .062" thick.

PC016-J-STD-F Hand Soldering Kit

Part Description	Quantity per Kit
PCB-J-STD-F-HASL	2
A-LQFP100-14mm-.5mm-2.0	4
PDIP16T	4
SO14GT-3.8mm	2
CK05	4
CK SPACER	4
Turret Terminal	4
Hook Terminal	4
Pierced Terminal	4
Bifurcated Terminal	4
Gold Cup Terminal	4
DO35	4
SOD80	4
TO5-3-B	4
TO5/TO18 SPACER	4
1206SMC	4
0805SMR	4
1206SMR	4
0402SMR	4
1/4-W-AR	4
PLCC20T	2
DPAK	4
26 Gauge Wire Brown	3'
22 Gauge Wire Grey	3'
20 Gauge Wire Red	3'
Kit Order Number:	PC016-J-STD-F

PC016-J-STD-F Lead Free Hand Soldering Kit

Part Description	Quantity per Kit
PCB-J-STD-F-ENIG	2
A-LQFP100-14mm-.5mm-2.0-Sn	4
PDIP16T-Sn	4
SO14GT-3.8mm-Sn	2
CK05-LF	4
CK SPACER	4
Turret Terminal	4
Hook Terminal	4
Pierced Terminal	4
Bifurcated Terminal	4
Gold Cup Terminal	4
DO35-LF	4
SOD80-Sn	4
TO5-3-B-Sn	4
TO5/TO18 SPACER	4
1206SMC-Sn	4
0805SMR-Sn	4
1206SMR-Sn	4
0402SMR-Sn	4
1/4-W-AR-LF	4
PLCC20T-Sn	2
DPAK-LF	4
26 Gauge Wire Brown	3'
22 Gauge Wire Grey	3'
20 Gauge Wire Red	3'
Kit Order Number:	PC016-J-STD-F-LF

Notes

- Board finishes available are: Immersion Silver, ENIG, Bare Copper, OSP and HASL.

J-STD-001F is world-recognized as the sole industry-consensus standard covering soldering materials and processes. This revision now includes support for lead free manufacturing, in addition to easier to understand criteria for materials, methods and verification for producing quality soldered interconnections and assemblies.

IPC/WHMA-A-620E-S Space Addendum Kit



IPC/WHMA Compliant

IPC/WHMA-A-620E-S provides additional requirements to ensure the reliability of cable and wire harness assemblies that must survive the vibration and thermal cyclic environments getting to and operating in space.

The IPC/WHMA-A-620E-S space addendum cannot be used as a standalone document, it must be used with the base standard IPC/WHMA-A-620E.

IPC/WHMA-A-620xS meets or exceeds the requirements set in NASA-STD-8739.4



Practical IPC/WHMA-A-620 Space Addendum Wire Harness Cable Training Kit.

Part# 17025 PC-A620E Space-Parts Only Kit

White 22 AWG	60 ft.
Green 18 AWG	2 ft.
22-2 AG-CU	5 ft.
18-3 AG-CU	3 ft.
RG58 Coaxial Cable	2 ft.
9 Position D-Sub Plug, Male Pins Connector	1
15 Position D-Sub Plug, Male Pins Connector	1
Contact Pin - 20-16 AWG, Size	3
Contact Pin - 24-20 AWG, Size	13
5 Position Circular Connector	1
12 Position Circular Connector	1
13 Position D-Sub Combo Receptacle	1
TNC Connector Plug, Male Pin	1
BNC Connector Plug, Male Pin	1
15 Position Hinged Backshell Connector	1
Connector Cable Clamp	1
Cable Tie, 4"	35
Spec Strain Reliefs & Adapters	1
Machined Conn D-Sub Socket, 14AWG	3
Shield braid, AG-CU, Size 1/4" dia, 10AWG	2 ft.
Sleeving, Fabric Braid, 1/2" dia, Nylon	2 ft.
Sleeving, Fabric Braid, 1/4" dia, Nylon	3 ft.
Sleeve w/o Gnd Wire, Size 3	4
Sleeve w/o Gnd Wire, Size 5	3
Ring Terminal Connector # 4, 16-22 AWG Crimp	1
Ring Terminal Connector #6, 16-22 AWG Crimp	8
Butt Splice Crimp - 16-22 AWG	1
1" x 6" white glass cloth tape	2 strips
1" wide cloth tape	1 roll
Lacing Tape	9 ft.
Shrink Tubing Kynar 3/64" DIA	2 ft.
Shrink Tubing Kynar 3/8" DIA	1 ft.
Shrink Tubing Kynar 1/4" DIA	1 ft.
Shrink Tubing Kynar 3/16" DIA	1 ft.
Shrink Tubing VITON 5/8" DIA	1 ft.
Harness ID Marker Plate	1

Part# 17026 PC-A620E Space Recert Kit

White 22 AWG	29 ft.
RG58 Coaxial Cable	1 ft.
Shrink Tubing Kynar 3/8" DIA	1 ft.1
Shrink Tubing Kynar 3/64" DIA	1 f
Cable Tie, 4"	20
Harness ID Marker Plate	6
9 Position D-Sub Plug, Male Pins Connector	1
15 Position D-Sub Plug, Male Pins Connector	1
TNC Connector Plug, Male Pin	1
BNC Connector Plug, Male Pin	1
Screw Retainer Kit	1
Protective cap 9 position	1

IPC/WHMA-A620 Wire Harness Kit

IPC/WHMA Compliant

The New A620 kit from Practical Components is designed to help companies meet industry standards for cable and wire harness assembly criteria. It helps teach the visual, electrical and mechanical quality

acceptability requirements for cable, wire and harness assemblies. You will also learn to identify target, acceptable, process indicator and defect conditions.

A620 Wire Harness Kit

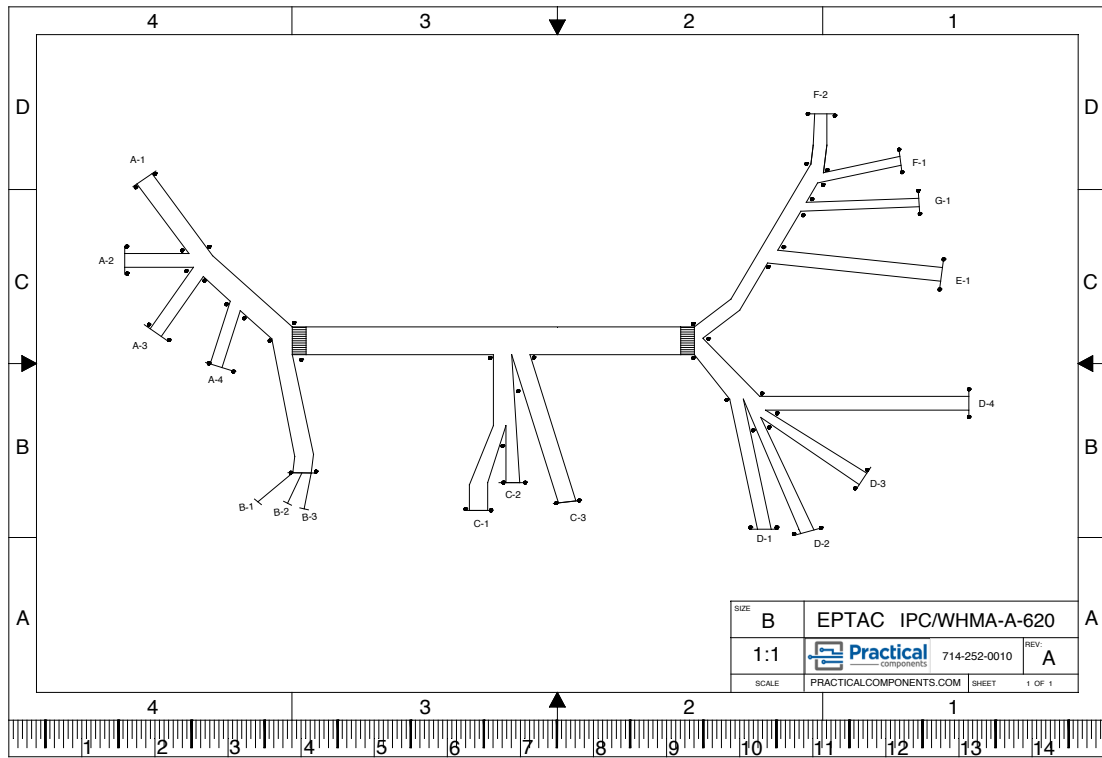

Board Size: 15 3/8" x 11" x 1 3/4" thick.

The A620 kit enable hands on training in the following areas of wire harness assembly:

- Cable and wire dimensioning, tolerances and preparation
- Crimp Terminations
- Insulation displacement connections
- Soldered terminations
- Splices
- Connectorization
- Marking and labeling
- Co-axial and ribbon cable assembly
- Wire bundle securing
- Installation
- Wire wrap (solderless)
- Testing of wire harness assemblies

The A620 kit comes with the recommended materials to become proficient with the IPC/WHMA-A-620 standard. Each kit is individually packaged with all items labeled. Call for recommended tools.

Lab/Manuel sold separately. Not included with kit.

A620 Parts Only

Part Description	Quantity Per Kit
Gold Cup Terminal	2
Turret Terminal	2
Bifurcated Terminal	2
Pierced Terminal	2
Hook Terminal	2
RV18-16L Isulated Ring	4
R18-6L Ring	4
Butt Splice	2
Machine Pin	3
Pin Contact	2
Pin Connector	2
2 AMP Connector	2
RJ45 Plug	2
Cable Tie	6
Strain Clip	2
18AWG Coaxial Cable	6'
22AWG Stranded	4'
23AWG Coaxial Cable	2'
24AWG Cat5E Stranded	4'
28AWG Ribbon Cable	1'
Lacing Cord	1 yrd

Lead-Free Zero-Ohm SMD Resistor Kit



REVISED [Rev. B]

The PCB000 test board has land patterns for 01005, 0201, 0402, and 0603 Zero Ohm Lead-Free SMD Resistors. Each component pad is connected in series (daisy-chained) to the next pad. When zero ohm value resistors are placed on the pad, the result is a line of continuity. This test board can be used for placement accuracy evaluation with any type of component

matching the physical size of the pads. Each component type has 2,000 pads, except for 01005 pad size which has 165 pads for Pick-n-Placement purposes only with four different pad spacing. There are also 48 pads for 01005 to test for continuity.

PCB000 Zero-Ohm Test Board

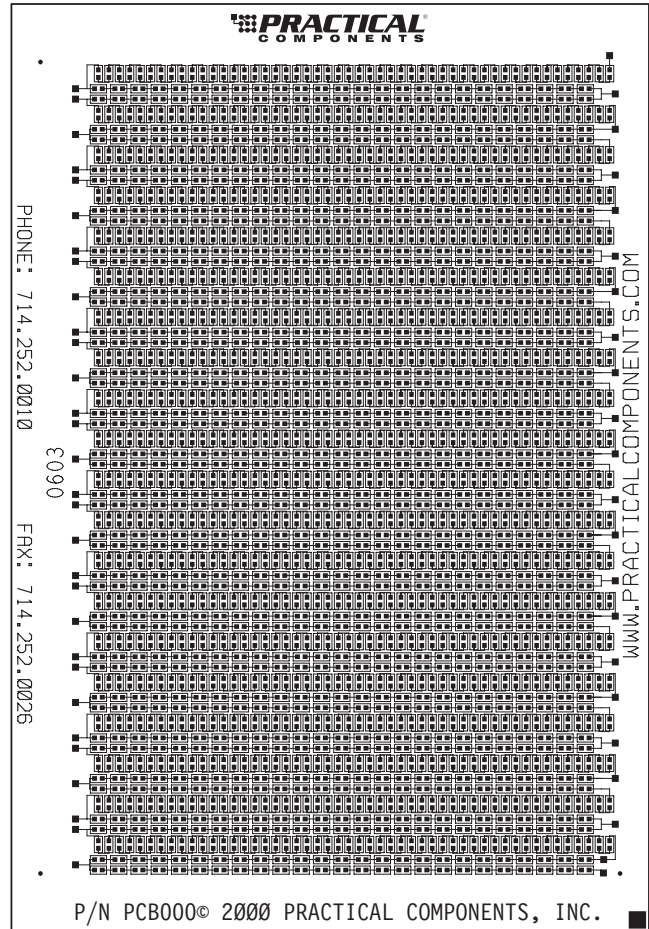
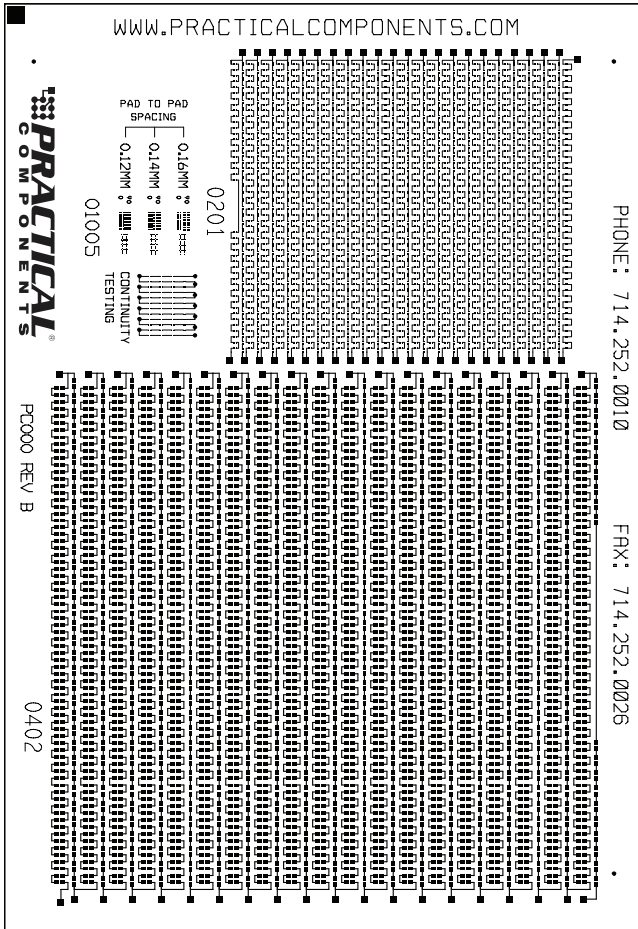

P/N PCB000© 2000 PRACTICAL COMPONENTS, INC.

Board size: 8" x 5.5", .062" thick.

SMD Resistors with Zero-Ohm value, and SMD Capacitors can be used on this test board. Customers can mix and match components and quantities to create a custom kit. Please contact your Practical Components sales representative for details.

PC000 SMD Lead-Free Zero-Ohm Resistor Kits

Part Description	Quantity Per 10 Kits	Quantity Per 25 Kits	Quantity Per 50 Kits
*01005SMR-PA-0-Sn	2,000	4,300	8,500
0201SMR-PA-0-Sn	20,000	50,000	100,000
0402SMR-PA-0-Sn	20,000	50,000	100,000
0603SMR-PA-0-Sn	20,000	50,000	100,000
PCB000-Zero Ohm Board	10	25	50
Kit Order Number (Lead-Free):	PC000-0-10-LF	PC000-0-25-LF	PC000-0-50-LF

Notes

- * 01005SMR-PA-0-Sn part is not included in kit. Can be added to kit-build upon request for additional price.
- Gerber and X, Y Theta data included at no charge.
- Digitized files provided by Aegis Software included at no charge.
- Board finishes available are:
Immersion Silver, ENIG, Bare Copper, OSP and HASL



AIM Solder Print Test Board and Kit

PCB2009 Rev B AIM Solder Print Test Board

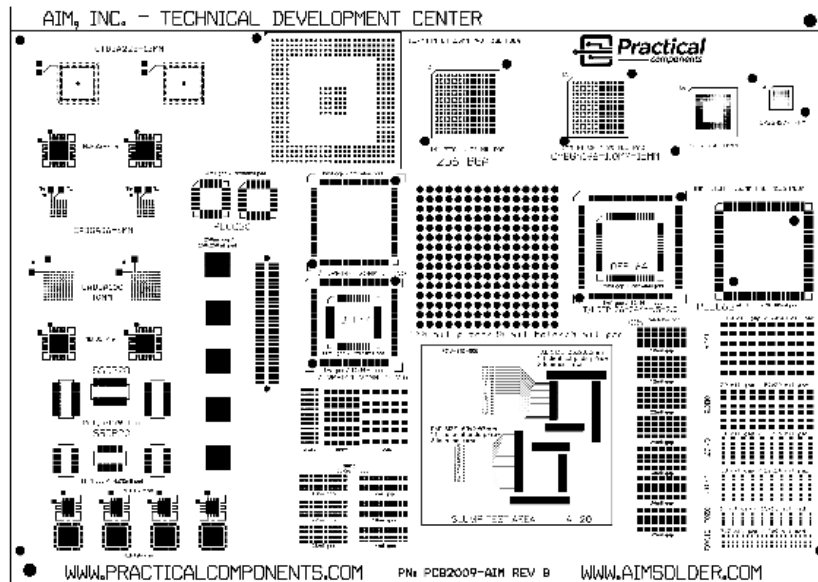

Board size: 8.5" x 6", .062" thick.

The \ PCB2009 Rev B print test board was designed to include many printing challenges commonly encountered on manufacturers' assemblies. The updated kit includes (2) CTBGA228-.5mm-12mm, (2) CABGA36-.8mm-6mm, (2) CABGA100-.8mm-10mm, (1) SMT connector and changed the MLF16-5mm-.8mm pad size. BGA pads have circular and square pad design to test paste release.

AIM has included the standard IPC slump test pattern in order to further challenge the properties of any product tested thereon. This print pattern is more real life and more accurate to predict slump since individual pads are used instead of one pad that is common in the "thermometer" method. There is a number on the board indicating the distances between pads so a hard number can be used for paste evaluations.

Solder practice test vehicle PCB boards and kits are for machine setup, evaluation, qualification, workflow analysis, prototyping, testing, solder profiling

Common pad sizes were incorporated into the layout including 1206, 0805 and 0603 rectangular pads for discrete components. These pads have varying distance between them so the user can determine solder beading of paste. Four 250 x 250mil pads are available to be utilized with various aperture styles in order to allow for wetting tests. There are also several fine pitch QFP pads designed to check for the propensity of any given product to cause bridging and to confirm the existence of torn prints, peaking (dog ears), or bridging.

Notes

- Digitized gerber files provided by Aegis Software included at no charge.
- Kit available with Tin/Lead and Pb-free components.
- Board finishes available are:
Immersion Silver, ENIG, Bare Copper, OSP and HASL.

PC2009 Rev B AIM Test Kit

Part Description	Quantity Per Board
PCB2009-AIM-RevB	1
PBGA388-127mm-35mm-DC	1
PBGA256-1.0mm-17mm-DC	1
CABGA196-1.0mm-15mm-DC	1
CVBGA97-.4mm-5mm-DC	1
CVBGA360-.4mm-10mm-DC	1
CTBGA228-.5mm-12mm-DC	2
CABGA36-.8mm-6mm-DC	2
CABGA100-.8mm-10mm-DC	2
MLF16-5mm-.8mm-DC	4
MLF32-7mm-.65mm-DC	4
MLF48-7mm-.5mm-DC	4
QFP44-10mm-.8mm-3.2mm	1
QFP64-14mm-.8mm-3.2mm	1
LQFP144-20mm-.5mm-2.0mm	2
PLCC20	2
PLCC68	1
SSOP20-3.9mm	3
SSOP28-3.9mm	3
PDIP14	14
01005SMR	57
0201SMR	30
0402SMR	30
0603SMR	174
0805SMR	148
1206SMR	45
Conn-SMT-2x16	1
Kit Order Number: (Tin-Lead) PCB2009-0-01-RevB	
Kit Order Number: (Lead-Free) PCB2009-0-01-LF-RevB	

SMT/PTH

Mixed Technology Pb-Free Kit



Indium Corporation SMT/PTH Mixed Technology Pb-Free Kit Practical Components and Indium Corporation are introducing a new Lead-Free SMT/Through-hole Mixed Technology test board and kit.

PCB049 Board

The PCB049 Board can be used to evaluate the following conditions:

- Solder paste wetting and spread.
- Solder paste slump performance.
- Solder perform Pin-in-Paste performance.
- Wave flux hole fill performance.
- P&P equipment and placement accuracy.
- Reflow process capabilities.
- Effectiveness of cleaning processes.
- Surface Insulation resistance (SIR).
- Surface finish interaction factors.
- Pb-Free Underfill performance.

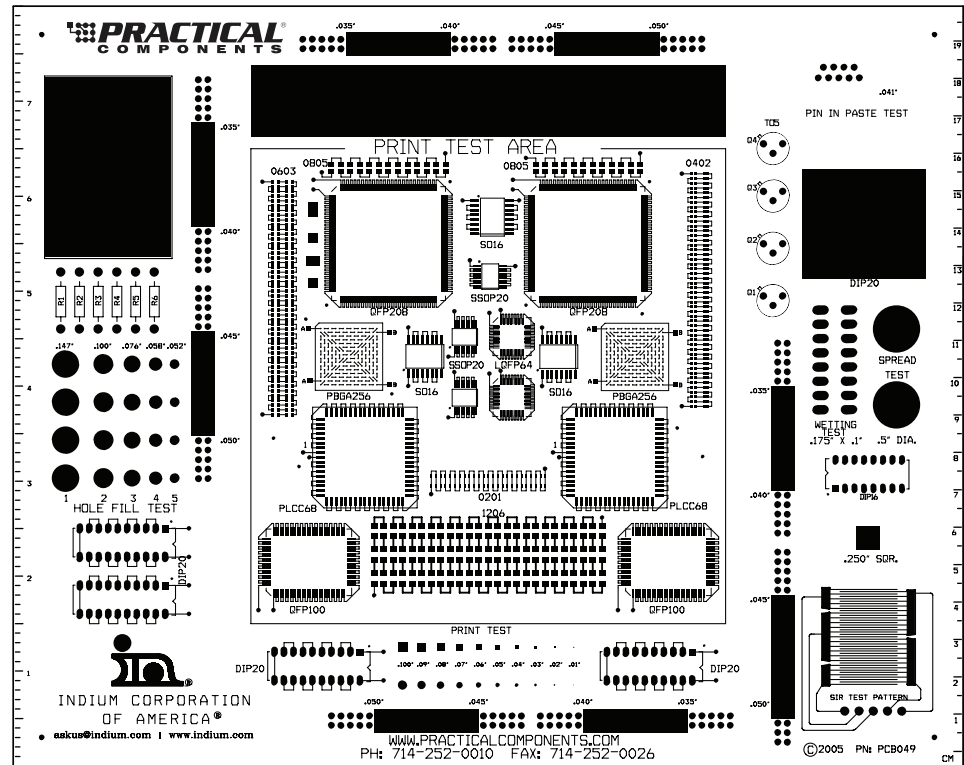

Board size: 10" x 8", .062" thick.

PC049 Indium Lead-Free Kit

Part Description	Quantity Per 25 Kits
A-PBGA256-1.0mm-17mm-DC-LF	50
LQFP64-7mm-.4mm-2.0-DC-Sn	50
A-QFP208-28mm-.5mm-2.6-DC-Sn	50
A-QFP100-14x20mm-.65-3.9-DC-Sn	50
A-SSOP20T-5.3mm-DC-Sn	75
A-SO16GT-7.6mm-DC-Sn	75
A-PLCC68T-DC-Sn	50
O201SMR-PA-0-Sn	1,250
O402SMR-PA-0-Sn	3,125
O603SMR-PA-0-Sn	3,125
1206SMR-PA-0-Sn	2,085
A-PDIP20T-7.6mm-DC-Sn	150
A-DIP16T-7.6mm-Sn	25
O805SMR-PA-0-Sn	1,050
1/4W-AR-Sn	175
TO5-Sn	100
Kit Order Number:	PC049-0-25-LF

Notes

- Board finishes available are: Immersion Silver, ENIG, Bare Copper, OSP and HASL.
- For details on evaluation techniques and material performance requirements, contact Indium Corporation technical support at 1-800-4-INDIUM.
- For complete information this kit or other Lead-Free solutions please contact your Practical Components representative at 1-714-252-0010.



Practical Components continues to offer high technology solder paste evaluation kits. The Jabil Solder paste evaluation test board and components is the most recent example.

This kit can be used to evaluate new solder paste and its performance for stencil printing and reflow characteristics. The kit can also be used to evaluate the compatibility with wave and rework chemistries. Other uses include ICT probability, comparison studies with different types of solder pastes, as well as internal development and evaluation.

The Jabil Solder Paste Evaluation Test Board is a good test design to evaluate solder paste. The bottom side of the test board has three 0.5mm pitch CTBGA84 patterns and three 0.4mm pitch CVBGA360 patterns which are used for solder paste volume measurements. The test board also has two bridging test patterns used to measure bridging after print. The pitch of pads of one pattern ranges from 8 to 20 mils.

The test board includes patterns for evaluation of bridging, wetting, solder balling, voiding and graping. The wetting pattern includes 12 vertical and 12 horizontal lines. The solder balling pattern includes 16 overprinted pads of 20 mil diameter and the graping pattern includes 4 columns of 6 pads.

Patterns for testing include:

- Bridging patterns
- Wetting/spread testing
- Solder balling pull back pattern
- Graphic pattern
- Solder paste volume
- Solder paste bridging
- Voiding Testing

Notes

- 1 board as the 3-up panel (1 Array = 3 Cards)
- MLF come standard on Tape and Reel but can be ordered in tubes upon special request.
- 2 stencils per kit = 1 Top / 1 Bottom. 29" x 29"
- Customer to specify stencil thickness: 1.5" or 0.5"

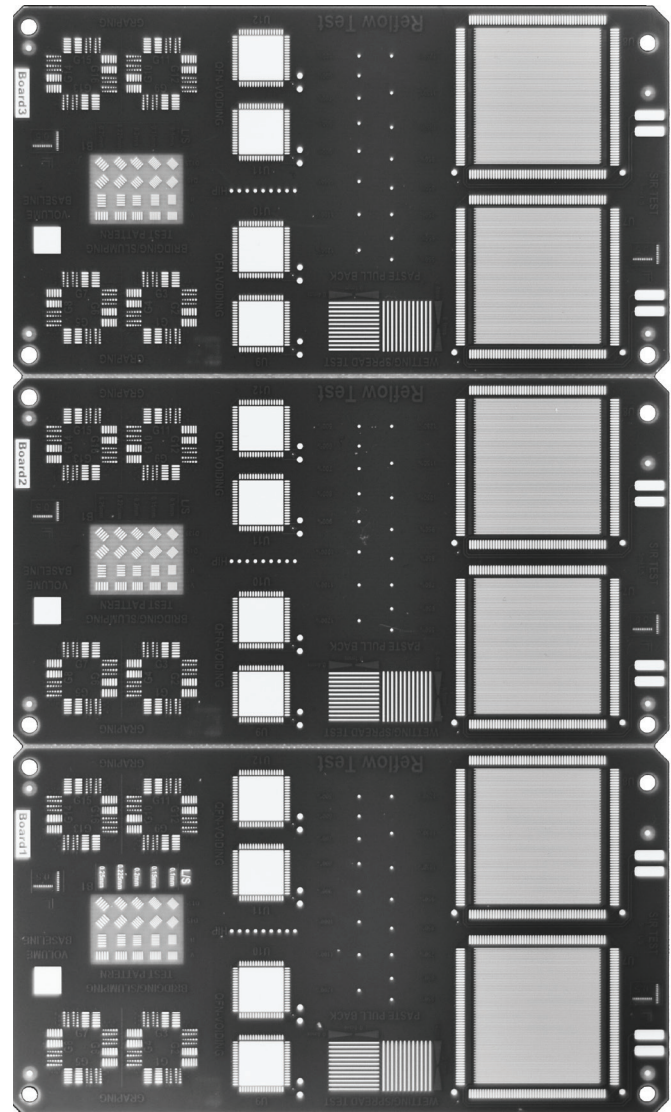

Ordering Information

Jabil SP Evaluation Kit #1

- Order Number: 12853
- (50) Jabil Test Boards
- (360) A-MLF68-10mm-.5mm-DC-Sn-TR
- (2) Jabil Test Board Stencils

Jabil SP Evaluation Kit #2

- Order Number: 12853
- (100) Jabil Test Boards
- (360) A-MLF68-10mm-.5mm-DC-Sn-TR

The following BGA are not included in the kit:

- Either BGA can be added to kit upon request.
- Order number: 32210 A-CVBGA360-.4mm-10mm-DC-LF-305
- Order number: 31407 A-CTBGA84-.5mm-6mm-DC-LF-305

115-1322 Epoxy Kit

This kit contains 10 packages of clear, low viscosity, superior strength epoxy, precisely measured out into two-compartment plastic packages so it's easy to use and there's no measuring.

Once cured, this epoxy makes an effective electrical insulator with good high temperature mechanical and impact resistance properties. The epoxy can be used to fill in holes, gaps, burns or to inject into delaminated locations. The kit also contains mixing sticks, mixing cups and foam swabs.

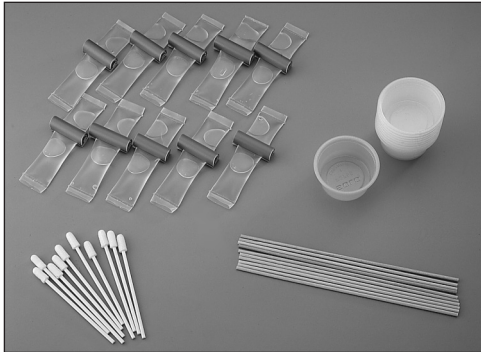

Applications

- Base Board Repair, Epoxy Method
- Base Board Repair, Edge Transplant Method
- Coating Replacement, Solder Mask
- RoHS Compliant

201-3140 Plated Hole Repair Kit

Here are all the tools and materials you'll need to repair damaged plated through holes in circuit boards.

The kit includes a variety of eyelet sizes, carbide ball mills for drilling, and setting tools to form the eyelets conforming to IPC guidelines. Eyelets are made of pure copper electroplated with solder. Eyelet tooling is hardened steel.

Application Notes

- Plated Hole Repair, No Inner Layer Connection
- Plated Hole Repair, Double Wall Method
- Plated Hole Repair, Inner Layer Connection
- RoHS Compliant



201-2100 Professional Repair Kit

The Professional Repair Kit is the most complete and most versatile circuit board repair kit you'll find anywhere. It's the total package.

The kit includes dry film, epoxy-backed circuit frames, and unique replacement circuits that do not use messy liquid epoxy. Includes eyelets and setting tools for plated through hole repair, Circuit Tracks to repair damaged circuits, epoxy and color agents for solder mask or base board repairs, and a comprehensive manual all packaged in a convenient carrying case.

If you need to repair damaged circuit boards, the all-in-one Professional Kit is what you need.

Applications

- Surface Mount Pad Repair
- BGA Pad Repair
- Land Repair
- Edge Contact Repair
- Conductor Repair
- Plated Hole Repair
- Base Board Repair, Epoxy Method
- Base Board Repair, Edge Transplant Method
- Coating Replacement
- RoHS Compliant

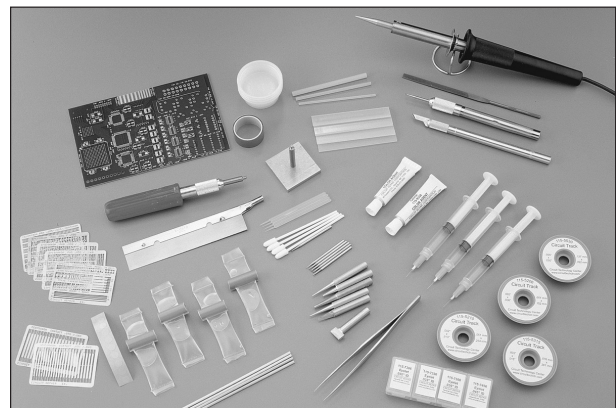

Professional Repair Kit is packaged in an ESD safe carry case



Practical
components
Notes



Practical
components

Notes