

REV	DATE	DESCRIPTION	BY	CHKD
07	01/18/02	ADDED EXPOSED PAD SIZE.	HJLEON	HJLEON
08	04/07/03	CORRECTED MAX. A2 TO 0.70.	HJLEON	HJLEON
09	09/12/03	ADDED 16LD AT 0.40 mm LAND.	HJLEON	HJLEON
10	11/22/03	ADDED 2.50mm PAD SIZE AT 20LD.	JHIGM	JHIGM
11	02/24/04	ADDED 28LD AT 0.40MM LEAD PITCH.	HJLEON	HJLEON
12	11/02/05	ADDED MIN. PKG HEIGHT.	HJLEON	HJLEON
13	01/09/06	CORRECTED TYPO.	HJLEON	HJLEON

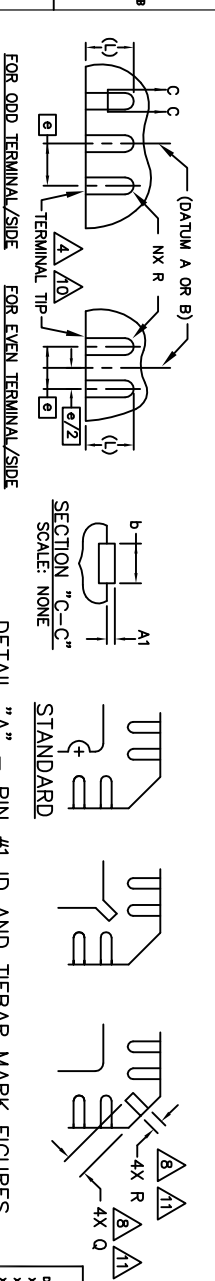
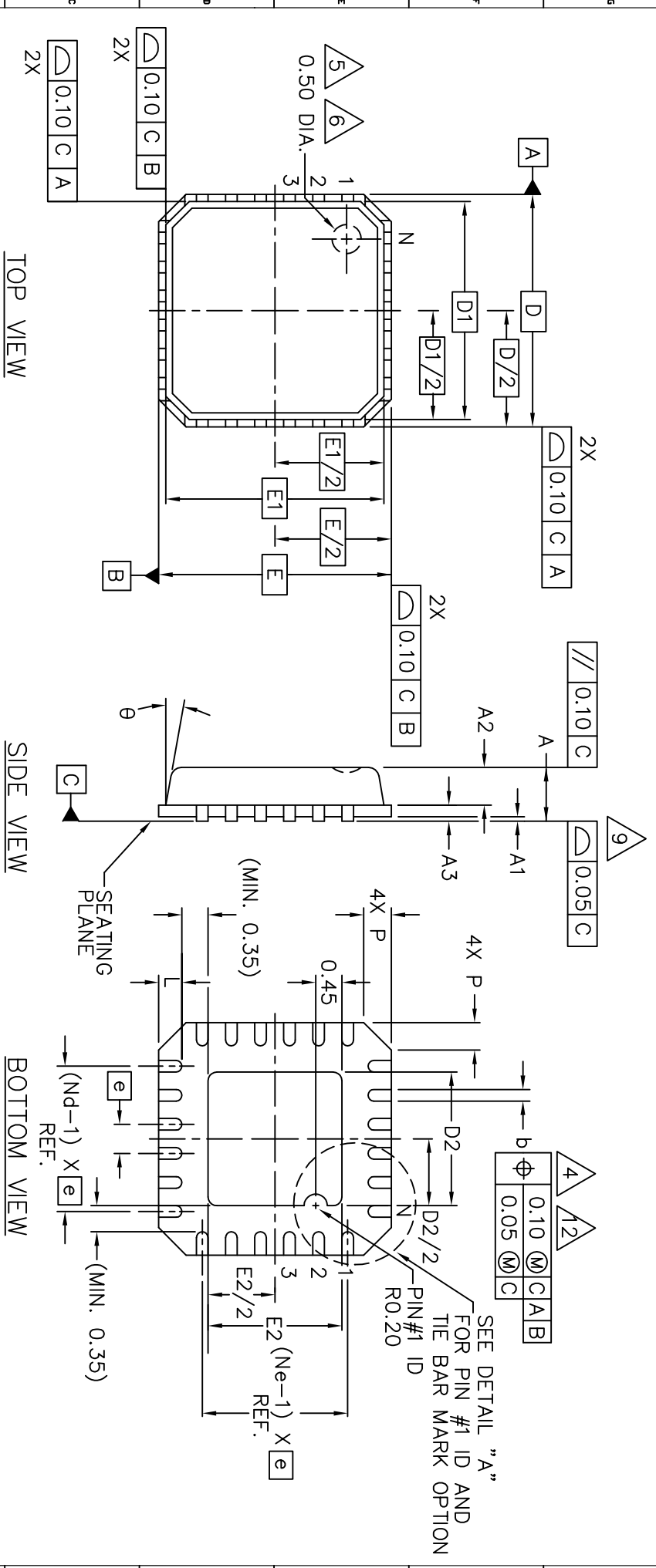

APPROVALS	DATE	TITLE
DESIGNED: HJLEON	09/28/01	PACKAGE OUTLINE, MLF2, 4 X 4 mm BODY
CHECKED: SSSANG	09/29/01	
DESIGNED: HJLEON	09/28/01	
CHECKED: SSSANG	09/29/01	
DESIGNED: HJLEON	09/28/01	
CHECKED: SSSANG	09/29/01	

UNLESS OTHERWISE SPECIFIED:  
DIMENSIONS ARE IN MILLIMETERS  
DECIMAL  
XX ± .1  
XXX ± .05  
INTERPRET DIM AND TOL PER  
ASME Y14.5M - 1994

FORM NO. MFR-LT-DAWING

THE DRAWINGS AND INFORMATION CONTAINED HEREIN ARE THE EXCLUSIVE PROPERTY OF AMKOR. THE INFORMATION, DRAWINGS AND DESIGN CONTAINED HEREIN ARE CONFIDENTIAL/PROPRIETARY. THE DRAWING NUMBER AND DATE SHALL NOT BE RELEASED TO ANY THIRD PARTY WITHOUT THE EXPRESS WRITTEN PERMISSION OF AMKOR.

AMKOR Technology www.amkor.com

PACKAGE OUTLINE, MLF2, 4 X 4 mm BODY

REV: 13

DATE: 15.1

FORM NO. MFR-LT-DAWING